



# WAYFINDING & SIGN SYSTEM STANDARDS MANUAL

Created by: © Guide Studio, Inc. [guidestudio.com](https://www.guidestudio.com)

VERSION 01 | MAY 2023

# Table of Contents

Introduction & Usage	ii
Route Classification	ii
Contact Information	iii

## SECTION 1 Graphic Standards

Colors & Materials	2
Fonts & Graphics	3
Mapping	4

## SECTION 2 Sign Family Overview

Sign Type Uses & Selection	6
Content Guidelines	10
Breezeway Nomenclature	11
Sign Anatomy & Color Use	12

## SECTION 3 Design Intent Drawings

Performance Specifications	14
Orientation/Map	
A1 Kiosk-Pylon	21
A2 Kiosk-Post & Panel	22
Direction	
B1 Directional	23
B2 Trailblazer	24
B3 Route Marker	25
B4 Pavement Marking	26

## APPENDIX Wayfinding & Signage Best Practices

Identification	
C1 Amenity/Service Identification	27
C2 Street Sign Topper Identification	28
C3 Jurisdiction Identification	29
Regulatory	
D1 Regulatory Custom Message	30
D2 Regulatory Rules	31

# Introduction & Usage

The purpose of this manual is to introduce the Montgomery County Bikeways Wayfinding and Sign System, providing instructions to those who may be planning, specifying, and maintaining signs throughout the county.

This Wayfinding and Sign System was developed to create a connective experience for people choosing to travel through Montgomery County via our extensive bikeway network. It is meant to provide a consistent presentation of brand and guidance information in the physical environment that not only supports comfort and safety, but encourages usage by all people, no matter their level of cycling experience. The system was designed for varying environments, using standard materials and components, with flexibility that allows for ease in changing and expanding information when necessary.

There may be instances where a nonstandard sign is necessary. This manual provides a standard for design intent. Any custom signs or deviations from the sign family must be approved by the Bikeways Coordinator at the Montgomery County Department of Transportation.

## INTENT

- » Create a standard wayfinding sign program for the trails and bikeways that connects Montgomery County.
- » Standards include the look and feel of the system of signs, guidelines for content, criteria for naming/nomenclature, and information hierarchy.
- » Create consistency in sign content and information hierarchy for people experiencing Montgomery County and its communities via the bikeways.
- » Support and promote the bikeways as an alternate way to see and experience Montgomery County and its communities.

## USING THIS MANUAL

- » **Section 1** introduces the Graphic Standards for the Sign Program. It addresses the use of graphic elements, logos and symbols, fonts, colors, materials, and nomenclature used within the program.
- » **Section 2** introduces the Sign Family. It includes programming and usage information for each sign type.
- » **Section 3** provides Design Intent-level drawings for each sign type, specifying layouts, element sizes, materials and recommended fabrication and mounting methods. Performance Specifications are included indicating instructions and requirements of the sign contractor.  
*Note: These drawings and notes are for the sole purpose of expressing visual design intent and are not intended to act as shop drawings for actual fabrication purposes.*
- » **Appendix** includes supplemental information, regulations, and guidelines for bikeway wayfinding and signage.

## Route Classification

The Montgomery County Bikeways network is a collection of all bicycle routes, both existing and proposed, that traverse Montgomery County. While routes may vary in facility types and physical surroundings, from a wayfinding and signage perspective, they are classified in two ways. Most routes are labeled as **Bikeways**. Those routes designated by the county as the “highest and best experience” will be labeled **Breezeways** and will be highlighted using a specialized branding element and color. The Wayfinding and Sign System utilizes color so that cyclists may quickly and easily distinguish between the route types in any environment.



Standard routes are identified as “Bikeways”, in dark green.



Breezeways are identified using a specialized version of the logo in cranberry.

See **Section 1** for more information regarding color & graphics.

---

## Contact Information

### **MONTGOMERY COUNTY BIKEWAYS WAYFINDING & SIGN SYSTEM**

For questions regarding the implementation of the Montgomery County Wayfinding & Sign System Standards, please contact:

**Matt Johnson**  
Bikeways Coordinator  
Division of Transportation Engineering  
Montgomery County Department of Transportation

[matt.johnson@montgomerycountymd.gov](mailto:matt.johnson@montgomerycountymd.gov)  
240-777-7237

**Jonathan Ryder**  
Senior Transportation Planner  
Countywide Planning and Policy Division  
Montgomery County Planning Department

[jon.ryder@montgomeryplanning.org](mailto:jon.ryder@montgomeryplanning.org)  
301-495-4596

### **SIGNAGE & WAYFINDING CONSULTANTS**

This manual was prepared by Guide Studio, Inc. under the direction of the Countywide Planning and Policy Division of the Montgomery County Planning and the Montgomery County Department of Transportation.



## SECTION 1

# Graphic Standards

---

Colors & Materials

---

Fonts & Graphics

---

Mapping



# Colors & Materials

## NEUTRAL COLORS



**Callout Note:**  
This label will be seen on the Design Intent Drawings to specify colors. The material (print, paint, vinyl) to be used will be based on the sign type component and application.

<b>Print</b>	Pantone® (Coated) CMYK	N/A 0 0 0 0	Process Black C 0 0 0 100	Process Black C 75% 0 0 0 75	Process Black C 25% 0 0 0 35
<b>Paint</b>	Matthews Paint	MP32071 White Wonder	MP33653 Black Stallion	MP12416 Shipyard Grey	MP08036 Gray Bunny
<b>Vinyl</b>	Opaque (3M™ 7725 Series)	3M Matte White 20	3M Matte Black 22	3M Dark Gray 41	3M Light Gray 121
	Reflective (3M™ High Intensity Prismatic)	3M White 3930	Print on 3M White 3930	Print on 3M White 3930	Print on 3M White 3930

## BRAND COLORS

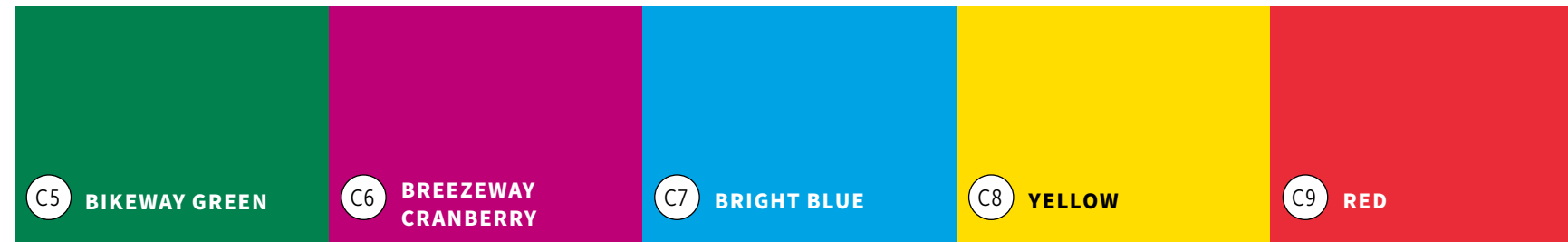

<b>Print</b>	Pantone® (Coated) CMYK	PMS 3415 C 100 0 85 29	PMS 227 C 3 100 0 20	PMS 3538 C 93 10 0 0	PMS 116 C 0 10 98 0	PMS 1795 C 0 96 82 1
<b>Paint</b>	Matthews Paint	MP14092 Donegal Green	MP05122 Fuschia Red	MP09133 Process Cyan U	MP10211 Citrus Yellow	MP10241 Red Camaro
<b>Vinyl</b>	Opaque (3M™ 7725 Series)	3M Bright Green 186	Print to match on 3M Matte White 20	3M Light Blue 107	3M Bright Yellow 15	3M Tomato Red 13
	Reflective (3M™ High Intensity Prismatic)	3M Green 3937	Print on 3M White 3930	Print on 3M White 3930	Print on 3M White 3930	Print on 3M White 3930

**Notes:**

1. Painted surfaces should have a satin finish unless specified otherwise in the sign type drawings.
2. Pantone® & CMYK values are provided as starting points for color matching. Printed colors should match the vinyl and/or paint color specified as closely as possible.
3. Certain sign faces or letters require retro-reflective graphics & may need to be printed on reflective white sheet to achieve proper color match (see sign type drawings).
4. MUTCD/MDOT requirements for retro-reflectivity must be met for bike and vehicular signage.
5. Final colors and materials must be approved prior to fabrication.

## MATERIALS

All materials specified as part of the system were selected for their durability, quality, changeability and compliance.

To keep costs down and maintain consistency, the majority of the components used in the sign system are standard sizes and materials readily available from several suppliers.

**Always separate dissimilar metals.**

See Performance Specifications & Design Intent Drawings for more details on materials.



### Sign Panels & Cabinets

To ensure durability & longevity, sign panels, cabinets, & exposed structural elements should be made of aluminum.



### Posts

The majority of the posts used in the sign system are to be standard galvanized steel posts.

# Fonts & Graphics

## FONTS

Fonts are copyrighted and cannot be transferred. Each user must obtain their own font licenses. It is the responsibility of the user to read each font's license for uses and restrictions. As of 2023, the fonts shown on this page can be downloaded for free at the links provided below.

### Source Sans Pro available at [fonts.google.com](https://fonts.google.com)

Aa Bb Cc Dd Ee Ff Gg Hh Ii Jj Kk Ll Mm Nn Oo Pp Qq  
Rr Ss Tt Uu Vv Ww Xx Yy Zz 1 2 3 4 5 6 7 8 9 0

**T1 Source Sans Pro Bold**

**T2 Source Sans Pro Semibold**

Source Sans Pro is primarily used for decorative text, brand elements, and pedestrian signage. Refer to the Design Intent Drawings for specific uses.

**T3 Source Sans Pro Regular**

**Callout Note:**  
This label will be seen on the Design Intent Drawings to specify fonts.  
Tracking (overall letter spacing) will be indicated on the drawings. If tracking is not noted, then tracking is 0% (normal).

### CLEARVIEW HWY available at [terminaldesign.com](https://terminaldesign.com)

Aa Bb Cc Dd Ee Ff Gg Hh Ii Jj Kk Ll Mm Nn Oo Pp Qq  
Rr Ss Tt Uu Vv Ww Xx Yy Zz 1 2 3 4 5 6 7 8 9 0

**T4 Clearview Hwy 2-W**

Clearview Hwy is MUTCD compliant and is primarily used for directional information on roadway signage. Refer to the Design Intent Drawings for specific uses.

## LOGOS & PATTERN

Owner to provide electronic artwork.



Logos may appear in black or white. Refer to Design Intent Drawings for uses.

The pattern may appear in various colors and opacities/tints. It may also be a gradient or solid. Refer to Design Intent Drawings for uses.

## ARROW

The directional arrow selected for the sign program is legible and easily-recognized. Owner to provide electronic artwork.

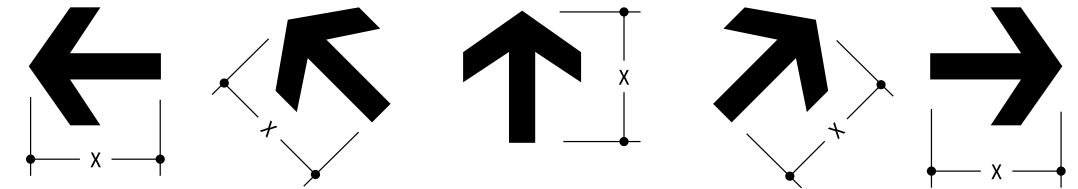

X dimension should remain the same when rotating arrow.

## SYMBOLS

Symbols, or pictograms, are an important tool in communicating to a diverse audience. Symbols cross language boundaries by employing images to identify and direct to public destinations and services. This sign program uses several of the internationally-recognized symbols utilized by the U.S. Department of Transportation and the National Park Service.

These symbols have been selected for use with the sign system. Any additional symbols must be reviewed and approved by the Bikeways Coordinator at the Montgomery County Department of Transportation prior to use.

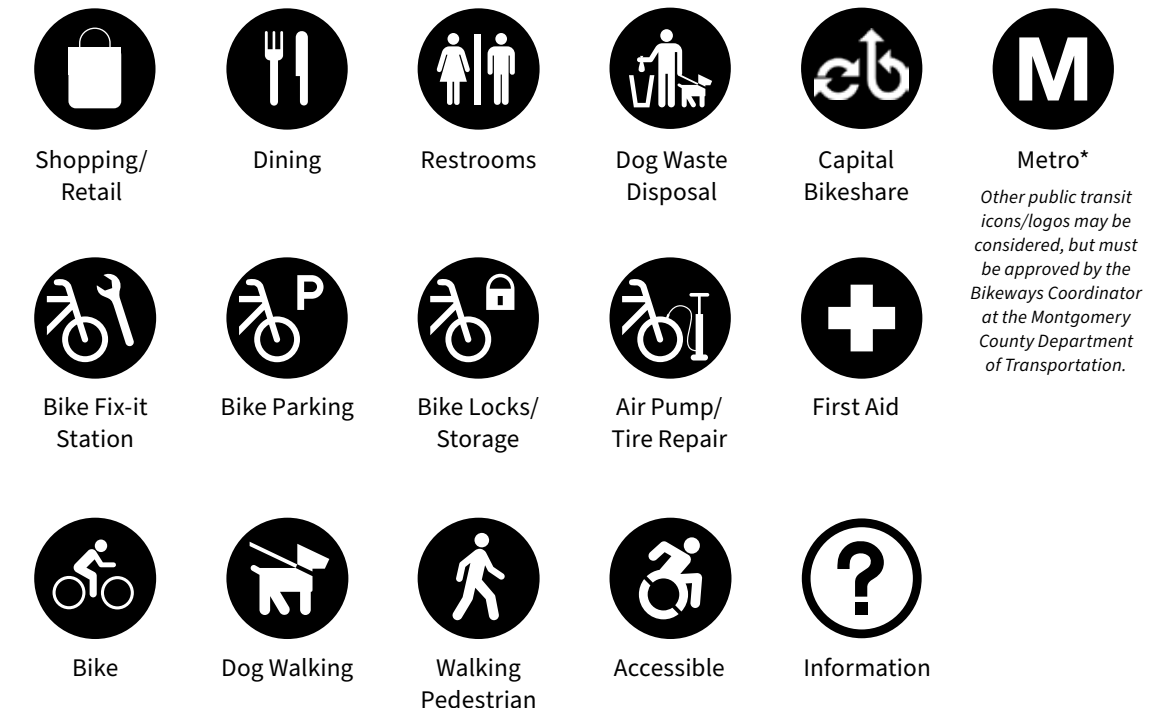

Symbols may or may not be contained within a circle, depending on sign type. See Design Intent Drawings.



# Mapping

Maps are an important component of the wayfinding program. They provide the user with the ability to orient themselves to an area and gain a greater perspective on how they can utilize the entire Bikeways System to plan, explore, and connect within Montgomery County.

Maps for this wayfinding system are unique to each area and will need to be developed as the sign system is implemented, however, consistent guidelines should be followed to provide the clearest and most effective information:

## MAPPING CHARACTERISTICS

- » **Heads-up Orientation:**  
Maps for wayfinding which are rotated in the direction of travel.
- » **Subway Style Design:**  
Schematic diagram style that simplifies the presentation of an area in favor of clear path of travel, connections and defined entry and exit points.
- » **Consistent Color Palette, Symbols, and Graphics:**  
The same colors, symbols, and drawing style should be used throughout the county and should match what is used on the signs

## MAPPING CONTENT

- » Bikeways/Breeeways
- » Connecting streets/roads/trails
- » Cities/Neighborhoods (include symbols to indicate available amenities)
- » Parks
- » Transit stops
- » Major landmarks
- » Public destinations (content should align with what is presented on directional signs for the area)



## EXAMPLE MAP

The above map is from the **Greater Cleveland/Cuyahoga County Off-road Trails & Bikeways Wayfinding Sign System Standards** as a reference for development of a Montgomery County Bikeways map. Note that the direction of travel (not North) is oriented up to provide the user a contextual understanding of their surroundings. By doing so, a destination shown to the right on the map, will be to the right of the user. In this example, the user knows to turn right to travel toward Lake Erie.

## SECTION 2

# Sign Family Overview

---

Sign Type Uses & Selection

---

Content Guidelines &  
Nomenclature

---

Sign Anatomy & Color Use



# Sign Type Uses & Selection

## Orientation/Map

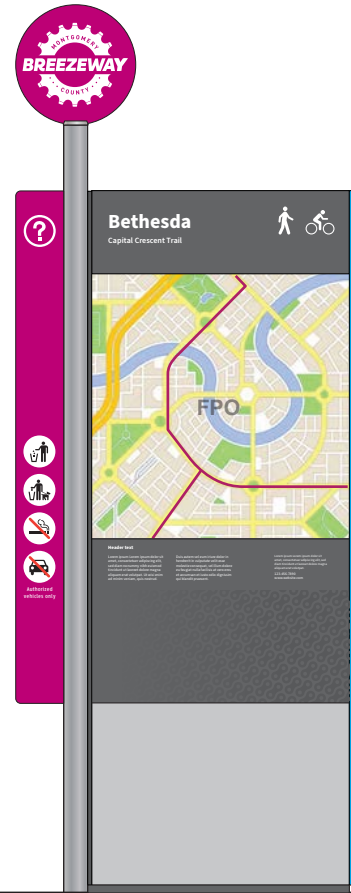

### A1 Kiosk-Pylon

3'-7" w x 9'-4" h

Double-sided aluminum monument sign.

Includes route type header, a large system-wide map showing all routes, major neighborhoods, cities, landmarks, etc., as well as a detailed blow-up showing local amenities, shops, institutions, transit stops, etc. May include advertising, donors, etc.

Located at major transition points into cities, districts, & neighborhoods so that the cyclist can orientate themselves to the area, as well large gathering areas such as plazas, parks, in front of libraries and other institutions.

Placed at spaces where cyclists have time & enough room to stop and read information that is detailed and more granular.

May be internally illuminated.

### A2 Kiosk-Post & Panel

2'-9" w x 8'-11" h

Double-sided post & panel sign.

Includes route type header, a large system-wide map showing all routes, major neighborhoods, cities, landmarks, etc., as well as a detailed blow-up showing local amenities, shops, institutions, transit stops, etc. May include advertising, donors, etc.

Located at large gathering areas such as plazas, parks, in front of libraries and other institutions, where less space is available than for the Pylon version. Intended to be easier to maintain and used along less trafficked routes.

Placed at spaces where cyclists have time & enough room to stop and read information that is detailed and more granular.

Non-illuminated.

*Images shown are for reference only. Refer to the Design Intent Drawings for details, construction methods, and optional configurations, colors, and components.*

# Sign Type Uses & Selection

## Direction

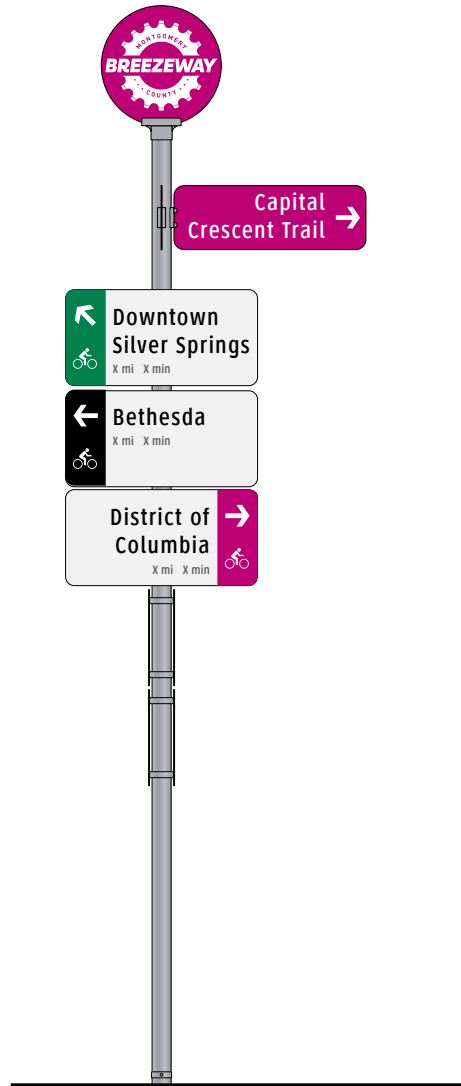

### B1 Directional

4'-3" w (max) x 11'-3" h

Multi-sided (up to four) modular post & panel sign.

Includes route type header, cross-route directional panels to indicate the name and type of route extending in each direction, and destination directional panels.

Placed at major decision points, primarily in more urban/busier areas. Sign should be placed before the actual decision point so the cyclist has time to plan their next move and react in enough time.

Includes reflective vinyl sign faces & graphics.



### B2 Trailblazer

2'-3" w x 6'-3" h

Single or double-sided modular post & panel sign.

Includes single direction, route type, and optional route type arrow panel.

Placed at secondary decision points (often one turn from destination), where only a single direction is needed. Ideally placed before the actual decision point so the cyclist has time to plan their next move and react in enough time, however, in condensed, low-traffic areas the sign may be placed at the intersection.

Includes reflective vinyl sign faces & graphics.

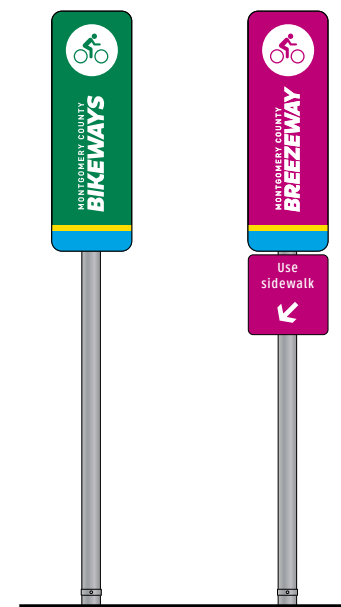

### B3 Route Marker

10" w x 6'-3" h

Single or double-sided modular post & panel sign.

Identifies route with color and branded panel.

Placed periodically along route to identify the route for cyclists and motorists. Confidence marker and giving confirmation of the route.

Can include a small instruction panel below branded route panel.

Includes reflective vinyl sign faces & graphics.



### B4 Pavement Marking

2'-2" w x 4'-0" h

Stenciled road pavement markings.

Includes typical sharrow symbol and cyclist symbol. Could include branded route type "Bikeways" or "Breezeway".

Placed periodically along route to identify the route for cyclists and motorists. Confidence marker and giving confirmation of the route. Used where the Route Marker would be ineffective or not possible.

Includes typical durable thermoplastic road pavement paint/markings.

Approval from MCDOT is required. If on a State Road, approval from MDOT SHA will be required.

Images shown are for reference only. Refer to the Design Intent Drawings for details, construction methods, and optional configurations, colors, and components.

# Sign Type Uses & Selection

## Identification



### C1 Amenity/Service Identification

1'-3" w x 10'-3" h

Single or double-sided post & panel sign.

Includes symbol only of amenity or service. 1-2 symbols possible and should not be exceeded.

Placed at amenity or service areas. Sign should be placed in highly visible locations.

Includes reflective vinyl sign faces & graphics.

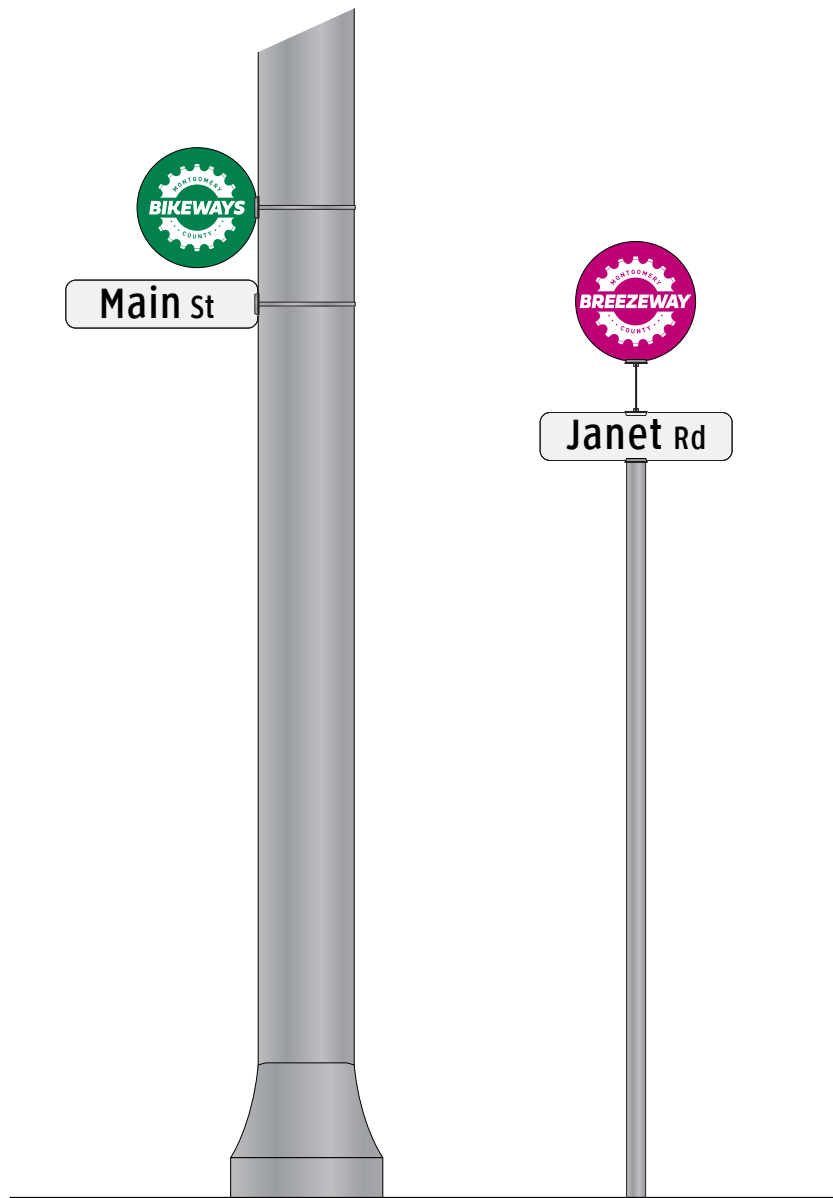

### C2 Street Sign Topper Identification

2'-3" w x 9'-7" h

Double-sided panel sign for use with existing or new street name signs.

Includes single direction, route type, and optional route type arrow panel.

Placed on top of street name sign panels.

Includes reflective vinyl sign faces & graphics.



### C3 Jurisdiction Identification

2'-3" w x 6'-3" h

Single or double-sided modular post & panel sign.

Includes welcome to and the jurisdiction name along with the route classification logo that identifies the route currently being traveled.

Placed at the border of a jurisdiction/area along a route to inform users of the change.

Includes reflective vinyl sign faces & graphics.

Images shown are for reference only. Refer to the Design Intent Drawings for details, construction methods, and optional configurations, colors, and components.

# Sign Type Uses & Selection

## Regulatory



### D1 Regulatory Custom Message

1'w x 5'-9"h (max)

Single or double-sided post & panel sign.

Includes symbols and/or area for a custom message to inform users. Information can range from special amenities, reminders, warnings, and general information.

Placed at areas where needed and as specific conditions dictate.

Includes reflective vinyl sign faces & graphics.

### D2 Regulatory Rules

1'-6"w x 8'-3"h

Single or double-sided post & panel sign.

Includes rules panel with post topper. Post topper route classification logo identifies the route currently being traveled.

Placed at busy/dense areas where there is a lot of traffic. Used to inform users of basic guidelines for using the system. Intended to promote a clean, safe, and enjoyable experience for all in perpetuity.

Includes reflective vinyl sign faces & graphics.

## Content Guidelines

The key to a successful wayfinding system is providing relevant information at the proper time and location. Signs that contain too much information are confusing, overwhelming, unsafe, and often ignored.

Information should be presented to a cyclist along their journey in a general to specific manner as they get closer to the destination. For example, a cyclist traveling from Aspen Hill to the Wheaton Library, does not need the Wheaton Library (or other Wheaton-specific locations) listed on signage outside of Wheaton. They simply need to be directed to Wheaton. Once in Wheaton, content can become more specific.

Messaging should be simple and clear, which may require shortening of names. Only highly recognized abbreviations should be used. A Sign Content Policy should be instituted that standardizes who and what can appear on signage. This policy will help manage and simplify information so that it can be easily comprehended by users.

### GENERAL CONTENT POLICY

In general, only civic/public destinations should be listed on directional signs and maps. **Private organizations and businesses change too frequently to ensure accuracy of information and ease of maintaining the system.** Other considerations include:

- » Open to the public
- » Have significant visitor interest
- » Open year-round
- » Give the local area a distinct identity
- » Reached by an easily identifiable and safe route

It is important to identify locations of comfort amenities such as places to eat, restrooms, stores, etc. However, since many of these types of amenities are privately owned and often exist in larger groupings, only general terminology such as “Shopping/Dining” is to be used.

Universally recognized symbols can also aid in quick recognition and are beneficial for foreign-speaking users. A family of symbols has been provided for use. **See Section 1 for symbols.**

### APPROVED DESTINATION TYPES

Destination types that are appropriate for inclusion as messages on signs include:

#### Places

- » Cities
- » Neighborhoods/Districts/Downtowns
- » Central Business Districts
- » Shopping/Dining Areas (No Specific Business Names)
- » Public Restrooms

#### Civic and Cultural Destinations

- » Highly-visited Government Offices
- » Libraries
- » Museums
- » Performance Art Venues
- » High Schools/Colleges (lower grade schools may be limited to signs within .5 miles or one-turn away)

#### Parks and Trails

- » Individual Parks
- » Park Systems
- » Adjoining Trails/Networks

#### Transportation

- » Breezeways
- » Rail/Bus Stations
- » Bikeshare/Rental locations
- » Parking
- » Bike “Fix-it” Facilities

#### Emergency Services

- » Hospitals/First Aid
- » Police/Fire stations

*There may be instances where nonstandard content is necessary. This list provides a standard for managing message content. Any custom requests or deviations must be approved by the Bikeways Coordinator at the Montgomery County Department of Transportation.*

## Breezeway Nomenclature

This page presents the approved Breezeway nomenclature (names) to be used in the The Montgomery County Bikeways network.

*\*Updated April 2023*

BREEZEWAY NAME	DESTINATIONS/END POINTS
Capital Crescent Trail	Downtown Silver Spring to DC Boundary
ICC Trail	City of Gaithersburg / Shady Grove METRO to Fairland / Prince George's County Line
Metropolitan Branch Trail	DC Boundary / Takoma Park to Silver Spring Transportation Center
Josiah Henson Breezeway	Falls Rd to Veirs Mill Rd
East County Breezeway	Downtown Silver Spring Library / Silver Spring Purple Line station to Howard County Line
Great Seneca Breezeway	North Germantown to Germantown Town Center to Shady Grove Rd / City of Rockville
Northern Crescent Trail	Powerline Trail to Burtonsville / Prince George's County Line
Veirs Mill Road Breezeway	City of Rockville to Downtown Wheaton
Germantown Breezeway	Germantown Town Center to Montgomery College
Powerline Trail	Germantown Recreational Park to Grosvenor METRO Station
Shady Grove Breezeway	Life Sciences Center to Shady Grove METRO Station
Democracy Breezeway	Potomac to Rock Spring / Old Georgetown Rd
Randolph Breezeway	Veirs Mill Rd to White Oak / US 29
University Breezeway	Downtown Wheaton to Takoma-Langley Transportation Center
Old Georgetown Breezeway	North Bethesda to Rock Spring via Old Georgetown Rd
Central Breezeway	Northern Portion: Clarksburg to City of Gaithersburg and City of Rockville Southern Portion: City of Rockville to Friendship Heights / DC Boundary (Includes the Bethesda Trolley Trail)
Mid-county Breezeway	Northern Portion: Olney / MD 108 to Wheaton Library Southern Portion: Wheaton Library to Downtown Silver Spring

**Contact the Bikeways Coordinator at the Montgomery County Department of Transportation for additional information and maps.**



# Sign Anatomy & Color Use

## TOPPER

The topper indicates what type of route the user is currently on.

Color Options:

(C5) Bikeway Green 

(C6) Breezeway Cranberry 

Logo is always (C1) (white)

Remember, the logo artwork changes based on route type as well. Colors should never be swapped between route types or altered in any way.

## DESTINATION DIRECTIONAL-ARROW BACKGROUND

The arrow background color indicates what type of route the user is will be on based on following that specific direction.

Color Options:

(C5) Bikeway Green 

(C6) Breezeway Cranberry 

(C2) Black 

Note: Black is used to designate a destination that is not accessed via the Bikeways network. In other words, the user will have to "exit" the Montgomery County Bikeways system.

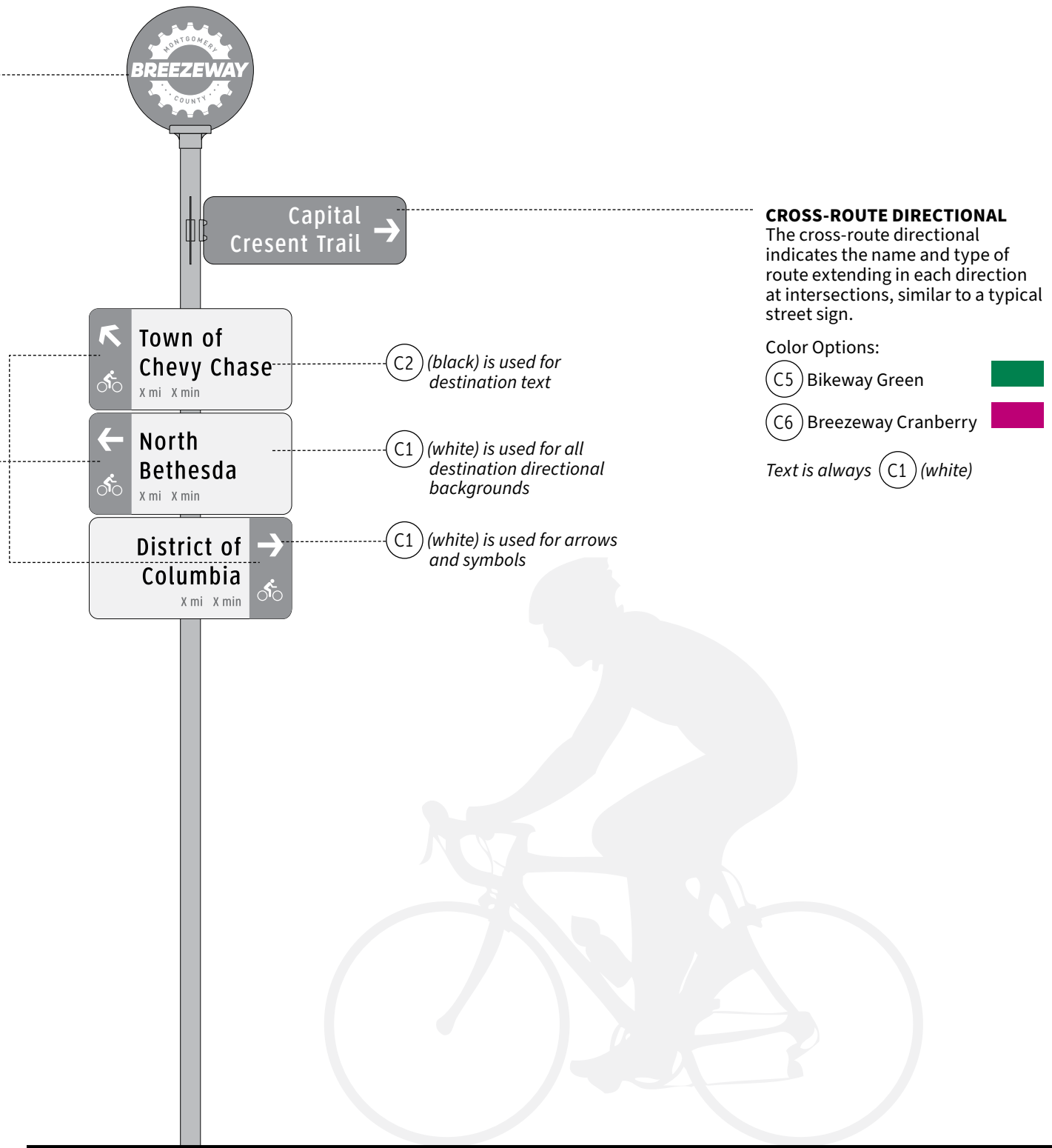

## CROSS-ROUTE DIRECTIONAL

The cross-route directional indicates the name and type of route extending in each direction at intersections, similar to a typical street sign.

Color Options:

(C5) Bikeway Green 

(C6) Breezeway Cranberry 

Text is always (C1) (white)

(C2) (black) is used for destination text

(C1) (white) is used for all destination directional backgrounds

(C1) (white) is used for arrows and symbols

## SIGN ANATOMY

Directional signs have been developed using a specific hierarchy of components so that users know where to expect certain information and its meaning in context of the entire Bikeways network.

## COLOR USAGE

A specific color system has been established for the Bikeways network that informs users of the route type they should expect to encounter making different decisions.

**It is important to follow these standards in order to maintain cohesiveness and clarity for users throughout the entire program.**

**See Section 1 – Route Classification and Colors & Materials for more information.**

## SECTION 3

# Design Intent Drawings

Performance Specifications

Sign Drawings



# Performance Specifications

## 1.0 General

### 1.1 Related Documents

Design Intent Drawings: These drawings/specifications are for the sole purpose of visual design intent only and not intended for construction purposes.

- A. The Sign Contractor is responsible for engineering, design, construction technique, materials and installation.
- B. The Project Owner/Contract Owner shall review the shop drawings only for conformance with general design intent, and will in no way be responsible or liable for any results of construction from working drawings, materials selection, shop drawings, contract documents or other agreements other than agreement with the Owner authorizing these documents.
- C. Sign Contractor shall verify and be responsible for all dimensions and conditions shown in the Design Intent documents. If dimensions are missing or are unclear — consult the Owner for direction. The Project Owner/Contract Owner must review shop details prior to fabrication.

### 1.2 Performance Specifications Introduction

The purpose of this document is to serve as a reference which identifies materials, construction specifications, and quality controls, as well as signage contractor's responsibilities and obligations. Signage Contractor(s) shall furnish and install signs and/or graphics as detailed on drawings and/or described in these specifications.

Refer to these performance specifications for details on designer expectations of Sign Contractor and fabrication process.

## 2.0 Definition of Terms

### 2.1 Documents

Refers to the drawings and specifications, including all addendum and modifications incorporated therein for their execution. When applicable, additional appendages provided by Owner or Designer shall become part of the documents.

### 2.2 Project Owner (also referred to as Owner):

Shall refer to:

Montgomery County Department of Transportation  
 Contact: Matt Johnson, Bikeways Coordinator  
 Division of Transportation Engineering  
 Montgomery County Department of Transportation  
 matt.johnson@montgomerycountymd.gov  
 240-777-7237

### 2.3 Designer

Shall refer to:  
 Guide Studio, Inc.  
 www.guidestudio.com

### 2.4 Signage Contractor/Fabricator

Refers to the group(s), firm(s), or corporation(s) designated in an Agreement with the Owner, and shall apply to any such group(s) under contractual obligation to perform any fabrication, installation, finishing, printing or other work related to signs and graphics, as referred in this document.

## 2.5 Work

As employed herein, includes any materials, equipment, construction, labor, installation, service or maintenance, and warranties required to complete the fabrication prescribed in these specifications and contract documents. This shall include, but is not limited to, all of the sign types shown in the drawings.

## 2.6 Addendum

Covering changes, corrections, and special interpretations of the drawings and specifications; shall become part of the documents.

## 2.7 Substitutions

When one or more than one product is specified and the signage contractor wishes to offer a substitute product which will completely accomplish the purpose of the contract documents, see section 6.0 for the conditions governing all substitutions.

## 2.8 NIC

Refers to work not included in this contract.

## 2.9 Final Completion

The date when the Owner finds the entire work as described in the contract documents acceptable and fully performed, as written in the final certificate of payment.

## 3.0 General Conditions

### 3.1 Quality Assurance

The Signage Contractor shall be responsible for the quality of materials and workmanship required for execution of this contract including the materials and workmanship of any firms or individuals who act as sub-contractors.

It is intended that the work described in these documents be of sound, quality construction. The Signage Contractor shall be solely responsible for the inclusion of adequate amounts to cover installation of all items indicated, described and/or implied.

### 3.2 Commencement

The work described in these documents shall only begin when a Owner-authorized, written contract has been issued to the Signage Contractor with instructions to proceed, provided other requirements have been met.

### 3.3 Contract Administration

Reviewing the quality and progress of the work and submittals received from the Signage Contractor, the Owner has no responsibility to assist the Signage Contractor in the supervision or performance of work. No action by the Owner shall in any way relieve the Signage Contractor from the responsibility for the performance of the work in accordance to the contract documents, or give rise to any negligence or other action against the Owner or anyone acting for their behalf.

Signage Contractor shall allow Owner or an authorized representative access to his plan, excluding such areas or processes judged by the Sign Contractor to be proprietary in nature for the purpose of inspecting production techniques, materials, or other items related to the manufacturing of which the Owner is committed, or which may be contemplated.

Upon notification from the Signage Contractor that the work is complete, the Owner or authorized representative (Designer) will inspect the final installation for compliance with all approved documents.

## Performance Specifications

### 3.4 Bidding Process

- A. All Bidders are required to complete any Bid Worksheet included as part of this package, as well as all County required bid documents.
- B. Incomplete Bid Worksheets may be cause for rejection of the bid.
- C. The Owner shall have the right to reject any or all bids, parts of such bid, and reserves the right to waive any informalities in the bid.
- D. In addition to bid price, the Owner reserves the right to consider all elements entering into the question of determining the responsibility of the Bidder. Any bid which is incomplete, conditional, obscure, contains additions not called for, or irregularities of any kind, may be cause for rejection of the bid.
- E. Bidders must present evidence to the Owner, when required by them to do so, to show they are fully competent and have the necessary source of supply, facilities and pecuniary resources to fulfill the conditions of the contract and specifications.
- F. RFI Process: All Requests for Information (RFI) must be submitted in writing via email to the distribution list established by the Bid Documents.  
  
Under no circumstances will RFIs submitted via direct phone call be answered. Responses to RFIs will be via email to all Bidders.

### 3.5 Artwork

The Signage Contractor will produce all artwork for all graphics, symbols and lettering, and will submit for review prior to fabrication. Artwork for specific items and logos, as noted on the drawing documents, shall be provided electronically by the Designer or Owner. All other artwork, as well as final artwork for final fabrication (including reproducible film positives) is to be provided by the Signage Contractor.

### 3.6 Other

Field dimensions shall be taken by the Signage Contractor prior to preparation of shop drawings and fabrication where possible.

All supplementary parts necessary to complete each item shall be furnished by the Signage Contractor, even though such parts are not definitely shown or specified. All anchors and other fasteners for securing work shall be included.

## 4.0 Signage Contractor Responsibilities

### 4.1 Design Responsibility

The graphic design requirements shown by the details on the sign type drawing documents are for design intent only and intended to establish basic dimensions of units or modules, profiles and sight lines of members, and appearance. Within these limitations, the Signage Contractor is responsible for fabrication of the entire system, and to make whatever modifications of and additions to the details as may be required. The visual design concept shall be maintained as shown, including members sizes, profiles and alignment of components as accurately as possible.

The Signage Contractor shall supplement the general design shown with detailed shop drawings for the Owner's approval. The shop drawings shall include major aspects of the system proposed, such as sections, shapes and connections of components and joints, how temperature movement is handled, venting, and anchorage to structure.

### 4.2 Statement of Application

The Signage Contractor, by commencing the work of the project, assumes overall responsibility, as part of his warranty of the work, to assure that all assembled components and parts shown that are required within the work of this project comply with the contract documents. The sign contractor shall fully warrant:

- A. That all components specified, or required, to satisfactorily complete the installation, are compatible with each other and with the conditions of installed and expected use.
- B. The overall effective integration and correctness of individual parts and the whole system.
- C. Compatibility with adjoining substrate, materials and other work by other trades.
- D. There shall be no premature material failure due to improper design of fabrication of the system. All materials are to fully perform to their normal life expectancy.

### 4.3 Statement of Execution

The Signage Contractor shall be responsible for all work done under his contract, including:

- A. Faulty or improper work of sub-contractor(s) and others under him by contract or otherwise.
- B. Diligent execution of work and giving personal attention and supervision to the same until complete.
- C. All delays caused by neglect on the part of the Sign Contractor or those under him by contract or otherwise.
- D. Compliance with all laws, ordinances and regulations bearing on the conduct of the work as drawn and specified.
- E. Obtaining, at the Sign Contractor's own cost, sign/construction permits, inspection certificates which may be required of the project by local authorities, or any other governing body. The Signage Contractor shall procure and pay for all permits, licenses and approvals necessary for the execution of the work.

### 4.4 Submittals

By the approval and submission of shop drawings and samples, the Signage Contractor thereby represents that he has determined and verified all field measurements, including heights, field construction criteria, materials, catalogue numbers and similar data or will do so, and that he has checked and coordinated each shop drawing and sample with the requirements of the work and the contract documents. Refer to Section 5.0 for list of required submittals.

### 4.5 Special Instructions

Signage contractor shall halt the graphics work when notified of a proposed change, or unsatisfactory results are anticipated. Signage contractor shall notify the Owner or authorized representative immediately and proceed only after receiving additional instructions from the Owner or authorized representative.

### 4.6 Protection and Handling of Products

Signage contractor shall store all graphic items under cover and off ground; handle in such manner as to protect surfaces and to prevent damage during storage, transport, installation and throughout remaining construction; protect exposed finishes by covering with adhesive paper or other suitable covering where adhesive is not appropriate for finish material; and apply covering prior to shipment from the fabricator or finishing shop. The covering shall not adversely affect finish. Signage contractor shall remove protective coverings when there is no longer any potential for damage to the graphics work from other work yet to be performed.

## Performance Specifications

### 4.7 Shipping and Transportation

Signage Contractor will be responsible for proper shipping and transportation of all signage to the job site and will specify whether it will be common carrier or their own trucks. Signage Contractor will be liable for all damage incurred during shipping and loss of time in the installation schedule.

### 4.8 Storage of Equipment

Space for storage of material prior to installation will be designated by the Owner. The Signage Contractor must give advance notice of deliveries and space requirements so the proper provision may be made. If deliveries are to be made to the premise at times other than normal working hours, the Signage Contractor will be required to reimburse Owner for any overtime costs incurred by Owner.

### 4.9 Warranty

- A. Upon final completion, the Signage Contractor will warrant all work and materials to be fully complete and in accordance with the contract documents and the agreement between Owner and Signage Contractor, and requirements appertaining thereto; that all work and materials are free from any and all defects and imperfections, and fully meet the manufacturer's published performance criteria for use and purposes for which each and every part is specified.
- B. The Signage Contractor also agrees that, should any defect develop or appear, which the Owner finds was not caused by improper use, the Signage Contractor shall promptly, upon demand, fully correct, substitute and make good any such defective material without cost to the Owner and will save the Owner harmless against any claim, demand, loss or damage by reason of any breach of this warranty.
- C. The period of this warranty shall commence on the date on which the Owner determines the Signage Contractor has met all Final Completion requirements. The period of said warranty shall last twelve (12) months unless otherwise specified.
- D. The special warranty specified in this Article shall not deprive the Owner of other rights the Owner may have under other provisions of the Contract Documents and shall be in addition to, and run concurrent with, other warranties made by the Contractor under requirements of the Contract Documents.
- E. Special Warranty: Manufacturer's standard form in which manufacturer agrees to repair or replace components of signs that fail in materials or workmanship within specified warranty period.
- F. Failures include, but are not limited to, the following:
  1. Deterioration of finishes beyond normal weathering.
  2. Structural failures.
  3. Noise or vibration caused by thermal movements.
  4. Failure of system to meet performance requirements.
  5. Failure of operating components to function normally.

### 4.10 Signage Contractor Responsibilities

The period of this warranty shall commence on the date on which the Owner determines the Signage Contractor has met all Final Completion requirements. The period of said warranty shall last twelve (12) months unless otherwise specified.

### 5.0 Submittals

All submittals and shop drawings are to be delivered to the Project Owner for distribution.

#### 5.1 Schedule

A detailed graphic schedule by phases of production and installation is to be submitted by the Sign Contractor within five (5) business days of signing of contract with the Owner.

#### 5.2 Samples

- A. The Sign Contractor shall submit (3) 4" x 4" samples of each color and finish of exposed materials, accessories and exposed fasteners on final material substrate to be used in the project.
- B. The Sign Contractor shall submit samples of each masonry material, including stone and mortar color to be used in the project. Brick and stone samples should be large enough to show variation in color adequate for review.

#### 5.3 Prototypes

- A. The Sign Contractor shall build (1) full size, functioning (illuminated) Orientation Kiosk (Sign Type G) to be reviewed and approved in the Sign Contractor's shop, prior to the fabrication of the sign program.
- B. This prototype will be used to establish standards for the materials and construction methods for the sign program. If accepted, the prototype may be used for installation at one of the designated locations.

#### 5.4 Shop Drawings

The Sign Contractor shall submit (1) one copy of electronic shop drawings in 11" x 17" format for the manufacturing, fabrication and erection of signs and graphic work at large scale, which shall show joints, anchorage, accessory items, and finishes. Shop drawings shall include accurately scaled masonry details, including finished sizes of brick, stone, mortar joints and foundations. Shop drawings shall be completed within 2 weeks the start of the Contract.

- A. Acceptance of shop drawings does not in any way change the documents. Documents may only be changed in writing.
- B. The Signage Contractor is responsible for reviewing shop drawings for conformance with the design intent documents and notifying, in writing, the Owner, of any variation from the documents.
- C. Changes to the shop drawings are to be made by the Signage Contractor as directed by the Owner. The Sign Contractor will receive 1 week for changes/updates as directed by the Owner.

#### 5.5 Manufacturer's Data

Signage Contractor shall submit (1) copy of the manufacturer's printed specifications, anchorage details and installation, and maintenance instructions for all products to be used in the fabrication of signs and graphics work.

### 6.0 Substitutions

#### 6.1 Any substitution requested will be considered under these cases:

- A. When specified product is not available.
- B. When certain product or process is specified, a warranty of performance is required, and, in the judgment of the Signage Contractor, the specified product or process will not produce the desired results.
- C. When such substitutions is in the best interest of the Owner.

#### 6.2 Requests for substitutions of products, materials or processes other than those specified will be accompanied

## Performance Specifications

by the evidence that the proposed substitution...

- A. Is equal in quality and serviceability to the specified item;
- B. Will not entail changes in details and construction related to work;
- C. Will be acceptable in consideration of the required design and artistic effect;
- D. Will provide cost advantage to the Owner.

The Sign Contractor shall furnish with his request such drawings, specification samples, performance data and other information as may be required of him to assist the Owner in determining whether the proposed substitution is acceptable. The burden of proof shall be upon the Signage Contractor.

**6.3** Regardless of the evidence submitted or any review or independent investigation by the Owner or authorized representative, a request for a substitution of products, materials, or processes is a warranty by the Signage Contractor to the Owner that the requested substitution...

- A. Is equal or better in quality and serviceability to the specified item;
- B. Will not entail changes in details and construction related to work;
- C. Will be acceptable in consideration of the required design and artistic effect;
- D. Will provide cost advantage to the Owner.

**6.4** Proposed substitutions will be made after the signing of the contract and not during the bid phase. Signage Contractor shall submit requests for substitutions to the Designer in writing with the first round of shop drawings, giving sufficient information and samples for evaluation with the differences in costs, if any. Substitutions must be approved in writing by the Owner before they may be used.

### 7.0 Products of Fabrication

Shop fabrication and tolerances shall conform to the standards of the industry. Signage Contractor shall perform high-quality, professional workmanship, attach materials with sufficient strength, number and spacing not to fail, and fabricate all work to be truly straight, plumb, level and square and to sizes, shapes and profiles indicated on the approved shop drawings.

#### 7.1 Materials and Workmanship

- A. The Signage Contractor shall use, whenever possible, standard sizes and readily available materials to reduce cost of fabrication. All materials shall be of the highest quality and shall meet all industry standards. To establish a standard quality, design and function desired, portions of the Design Intent Documents and specifications may be based on products or manufacturers herein. When specific products are mentioned, it should be noted that the manufacturers of similar products may be considered for approvals as "equal" by the Owner upon receipt of adequate supporting data.
- B. All materials utilized for the work of this contract shall meet all applicable codes, including Fire and Life Safety codes, of authorities having jurisdiction over the projects. The Sign Contractor shall immediately report any discrepancies to the Designer for resolution. The Contractor shall not substitute products without obtaining prior written approval from the Owner and Designer.
- C. All sign faces shall be smooth and even, free from imperfections and disfiguring caused by such things as welding, material being too thin, fasteners and welds not being ground smooth, oil canning,

staining, discoloration or uneven coloration, puckering, or any other problems not specifically mentioned herein.

- D. Climate conditions of the project site must be considered and the sign units designed and engineered to prevent problems caused by weather, expansion, contraction, condensation, and any other possible problems resulting from exposure to the elements.
- E. Weep holes, heat vents, etc. shall be considered for incorporation by the Sign Contractor on each sign type as required and/or necessary. Weep holes, vents, access panels and other functional, but non-aesthetic, components must be placed so as to be inconspicuous as possible. All such items must be shown on the shop drawings for approval prior to fabrication.
- F. All finish work shall be smooth and free from abrasion, tool marks, visible welds, exposed fasteners or similar defects. All corners, reveals and joints shall be milled to matching adjoining pieces and shall be fabricated so that they are straight and/or configured to match the Design Intent Documents.
- G. Defective workmanship of any type shall not be tolerated and will result in rejection of the supplied product.

### 7.2 Systems Performance Requirements

- A. General: Signage Contractor shall engineer, fabricate and install signs to meet Performance Requirements included in these Specifications and the following criteria:
  1. Code Compliance: Work, including structural loading, shall comply with all applicable Federal, State and Local Codes and applicable regulations of authorities having jurisdiction including ADA compliance.
  2. Design Criteria: The Drawings and Specifications indicate sizes, colors, layouts, profiles, critical details and dimensional requirements of signs.
- B. Windloading: All sign types and supporting devices, anchorage, etc. must be designed to withstand a wind speed of 100 mph (unless specified otherwise by relevant Maryland statutes) on the total sign area applied in all directions and comply with all applicable codes.
- C. Thermal Movement Temperature Change (range): 120 degrees Fahrenheit ambient, 180 degrees Fahrenheit material surfaces.
- D. Control of Corrosion: Prevent galvanic action and other forms of corrosion by insulating metals and other materials from direct contact with incompatible materials.

### 7.3 Typography & Graphics

- A. The Sign Contractor shall report any discrepancies or conflicting sign specifications, such as message too long for specified format, to the Designer for resolution.
- B. The applicable typefaces for this project shall be indicated in the design documents. All fonts specified must be purchased by the Sign Contractor for use in this program.
- C. Electronic art for graphics, logos and symbols shall be supplied by the Owner or Designer for the Sign Contractor's use in producing electronically cut images, patterns, or friskets. This is the only acceptable source of art for the logos and symbols. Sign Contractor shall not use artwork included as part of these Documents for final photography or digitizing.

## Performance Specifications

- D. All final output or implementation of typography and graphics are to be sharp (without serrated or irregular edges) and exactly true to the letter style and/or design form.
- E. Sign Contractor shall allow for hand kerning of messages, at no additional cost, in which letters and numbers, although adequately spaced, appear to the Designer to be less readable, or unsatisfactorily spaced.

### 7.4 Color

- A. Color Specifications: Sign Contractor shall provide products matching those listed below in both color and quality. For colors requiring a match, products shall be used which best match the paint swatch specified. Samples shall be submitted in accordance with the requirements of Section 5.0 and of these Specifications for approval prior to fabrication.
- B. Color specifications for the work of the project are listed in the Design Documents.
- C. Consult the Design Documents to ascertain all sign components to receive color.
- D. Coatings are to accurately match the color specified. The number of coatings must be adequate to achieve the color specified. Three (3) samples of each color using the actual coating type must be submitted for approval prior to production, in accordance with Section 5.0 of these Specifications.

### 7.5 Finish

- A. All coating applications are to be smooth and consistently uniform. The cured coating surface is to have a uniform finish that matches the specified color and finish.
- B. Exact identification of all coatings and a description of the method of application shall be identified in the Shop Drawings.
- C. Color breaks that occur on the sign face are to be sharp, even, with no serration or color bleed. All splatters, drips, spills and over sprays shall be removed.
- D. Comply with NAAMM's "Metal Finishes Manual for Architectural and Metal Products" for recommendations for applying and designating finishes.
- E. Protect mechanical finishes on exposed surfaces from damage by applying a strippable, temporary protective covering before shipping.
- F. Appearance of Finished Work: Variations in appearance of abutting or adjacent pieces are acceptable if they are within one-half of the range of approved Samples. Noticeable variations in the same piece are not acceptable. Variations in appearance of other components are acceptable if they are within the range of approved Samples and are assembled or installed to minimize contrast.

### 7.6 Screen Printed Media

- A. All screen-printed graphics shall be produced with ABS paint compatible with the substrate, using mesh of 390 or finer to produce clean, sharp edges.
- B. All media are to be opaque, with full even coverage, and free from dust bubbles, blemishes and other foreign matter.
- C. There shall be no streaking created by drawing squeegee over screen.

### 7.7 Masonry

- A. Scope: The Contractor shall furnish all labor, materials, tools, equipment and scaffolding, transportation, cartage, etc., required for the complete installation of all masonry as shown on the drawings and specified herein.

- B. Built-in Items: The Contractor shall build into the masonry, where required, all bolts, anchors, inserts, and the like.
- C. Protection: Masonry work shall be protected from freezing and from the elements at all times. The tops of masonry walls shall be covered at nights and at other times as required when not being worked on, with a waterproof covering to prevent water from entering the wall.
- D. Workmanship: All masonry work to be built up with true and even surfaces to proper heights, dimensions and forms, and carefully plumbed and leveled in all cases. All work is to be carried up continuously insofar as practicable.
- E. Performance: All exterior masonry construction shall be so built that it will be completely weather-tight and for a period of one (1) year from the completion and final acceptance of the building, the Masonry Contractor shall so guarantee.

### 7.8 Digitally Printed Graphics

- A. Applied graphics should securely adhere to sign surfaces, and be applied smoothly: free of peeling, bubbling or other application defects. Graphics are expected to resist peeling and hold to applied surfaces considering the exterior conditions (resistant to temperature fluctuations and moisture).
- B. Opaque continuous tone photo-quality print - minimum 720 DPI per sq. inch. Graphics may be printed directly to substrate and be applied smoothly: free of peeling, bubbling or other application defects. Graphics are expected to hold to applied surfaces. Graphics should utilize inks resistant to UV-A, UV-B, Xenon and weather. Any graphics used outside should be exterior-rated: resistant to vandalism, fading and other weather-related defects.
- C. Where applicable, digital graphics shall be printed on reflective white and must be retro-reflective where indicated per MUTCD standards unless specified otherwise in the Design Intent Drawings.

### 7.9 Vinyl Film

- A. Contractor shall provide opaque or reflective high performance vinyl film as indicated on the Drawings, 2 mil maximum thickness, with pressure sensitive adhesive, suitable for outdoor application to vinyl, painted surfaces, and metal applications.
- B. All machine cut vinyl typography and graphics are to be on high-grade self-adhesive 2 mil maximum high performance, cast vinyl films with a minimum of (7) years durability or approved equal (or otherwise noted). The application of the vinyl characters is to be smooth, without bubbles, ridges or other imperfections.
- C. All vinyl typography (including letters, arrows, numbers, symbols, logos, etc.) shall be digitally reproduced, and machine cut.
- D. Surface coatings should be allowed to dry a minimum of 3 to 4 days before applying vinyl letters or graphics in order to avoid bubbles forming in the vinyl from out-gassing of the curing coating.
- E. Letters for sign panels are to have positionable pressure-activated gray pigmented adhesive to provide minimal color show through.
- F. Vinyl shall be retro-reflective where indicated per MUTCD standards unless specified otherwise in the Design Intent Drawings.

### 7.10 Aluminum & Steel

- Separation of Metals: There shall be no bare aluminum in contact with any other metals, wood or concrete. Contact surfaces shall be separated by a coating of zinc chromate and aluminum paint, or a heavy body

## Performance Specifications

bituminous paint or by a gasket.

- A. Aluminum Castings: ASTM B 26/B 26M, of alloy and temper recommended by sign manufacturer for casting process used and for use and finish indicated.
- B. Aluminum Sheet and Plate: ASTM B 209 (ASTM B 209M), alloy and temper recommended by aluminum producer and finisher for type of use and finish indicated, and with at least the strength and durability properties of Alloy 5005-H32.
- C. Aluminum Extrusions: ASTM B 221 (ASTM B 221M), alloy and temper recommended by aluminum producer and finisher for type of use and finish indicated, and with at least the strength and durability properties of Alloy 6063-T5.
- D. Steel Members Fabricated from Plate or Bar Stock: ASTM A 529/A 529M or ASTM A 572/A 572M, 42,000-psi (290-MPa) minimum yield strength.
- E. For steel exposed to view on completion, provide materials having flat, smooth surfaces without blemishes. Do not use materials whose surfaces exhibit pitting, seam marks, roller marks, rolled trade names, or roughness.

### 7.11 Laser-cut Characters

Provide characters with square-cut smooth edges.

### 7.12 Acrylic Sheet

Acrylic Sheet: ASTM D 4802, Category A-1 (cell-cast sheet), Type UVA (UV absorbing).

### 7.13 Paints/Coatings/Finishes

- A. Surface Preparation: Signage Contractor shall remove mill scale and rust, if present from uncoated steel and prime for painted finish.
- B. Only highest quality 2-part catalyst-hardened acrylic polymer coatings are to be used. Color fastness is of utmost importance as well as quality and other assurances against abnormal deterioration such as peeling, cracking, crazing, etc.
- C. Coatings shall be prepared as designated by the manufacturers latest literature for surface preparation and application but in no case less than one (1) applicable primer coat and two (2) final full coats. All finished surfaces shall be uniform.
- D. All coatings (paint, ink, etc.) should have UV inhibitors, and should not fade or discolor when exposed to ultraviolet light.
- E. Colors shall match color designations as indicated on the drawings.
- F. Sign Contractor shall protect mechanical finishes on exposed surfaces from damage by applying strippable, temporary protective covering before shipping.
- G. All paint finishes are to be satin unless otherwise noted in the Design Drawings.

### 7.14 Fasteners

Signage Contractor shall use concealed fasteners fabricated from metals that are not corrosive to the sign material and mounting surface. All dissimilar materials must be separated from contact with each other. Fasteners shall be compatible with adjacent materials and substrates.

- A. Anchors and Inserts: Signage Contractor shall use nonferrous metal or hot-dipped galvanized anchors and inserts for exterior installations and elsewhere as required for corrosion resistance. Signage Contractor shall use expansion bolts or other fastening devices for drilled-in-place anchors designed

to withstand all required loads. Signage Contractor shall furnish inserts, as required, to be set into concrete or masonry work.

- B. Exposed Fasteners: Sign Contractor shall finish exposed fasteners to match adjacent surfaces and as directed by Designer to achieve an attractive, finished appearance.

### 7.15 Illumination

- A. All internally illuminated signs shall be illuminated using the Manufacturer's standard LED lighting and shall include transformers, insulators, and other components. Make provisions for servicing and concealing connections to electrical systems.
- B. Sign Contractor shall be responsible for painting the inside of signs or providing diffusers, if needed, to achieve proper level of illumination.
- C. Electrical Components, Devices, and Accessories: All materials and equipment shall be listed, labeled or certified by Underwriters Laboratories, Inc, or by a testing agency acceptable to authorities having jurisdiction, and marked for intended use.

## 8.0 Fabrication

Signage Contractor shall provide sign copy to comply with the requirements indicated for size, styles, spacing, content, positions, materials, finishes, and colors of letters, numbers and symbols, and other graphic devices and construct to accurate details and dimensions as shown, and as reviewed on shop drawings. Exposed fasteners on finished sign faces will not be allowed, unless specifically indicated. Signage Contractor shall conceal wiring, conduit, and other electrical items within sign enclosures.

### 8.1 Shop Assembly

Signage Contractor shall pre-assemble items in shop to greatest extent possible to minimize field splicing and assembly. Signage Contractor shall disassemble units only as necessary for shipping and handling limitations. Signage Contractor shall clearly mark units for reassembly and coordinated installation.

### 8.2 Welding

All welding procedures shall conform to applicable AWS specifications. Type of alloy filler metal and electrodes to be that which is recommended by producer of metal to be welded, and as required for color match, strength and compatibility in the fabricated items.

### 8.3 Flatness of Panels

Panels shall show no visible distortion when viewed in installed position.

### 8.4 Cutting/Routing

Signage Contractor shall cut and route in a manner to produce smooth, true, and clean edges and corners of finished graphics and letterforms. Graphics and letterforms having positive or negative corners, nicked, cut or ragged edges are not acceptable. Signage Contractor shall align and maintain parallel baselines and margins as indicated on the drawings.

## 9.0 Execution

Quality and acceptability of the fabricators' work will be monitored throughout the fabrication and installation phases of the project. Work will be reviewed by the Designer.

### 9.1 Shop Reviews

Contractor shall notify Owner at least 48 hours in advance of operations requiring reviews.

### 9.2 Site Reviews

Upon arrival of any shipment of sign units or materials, the Sign Contractor shall inspect the shipment to



## Performance Specifications

verify that no damage has occurred that will adversely affect the performance or appearance of the units or materials. The Owner shall not accept, as approved, any units or materials previously rejected.

### 9.3 Sign Locations

The Sign Contractor shall field verify all proposed sign locations and conduct a walk-thru with the Owner in order to obtain a written approval of the proposed locations before installation of the sign units. All locations must be permitted through the appropriate permitting/approval process (by Sign Contractor).

### 9.4 Punch List

Immediately after installation of the signs, the Sign Contractor shall arrange for the Owner to review the work in place and give written notice of any deviations, errors, omissions or other unacceptable condition in a punch list to be prepared and distributed to the proper fabricators or consultants for correction.

### 9.5 Final Sign-Off

At final completion of all work, including punch list items for each group of signs, the Sign Contractor shall arrange for a final review by the Owner for the purpose of obtaining a written approval of the fabrication and installation of the units.

## 10.0 Installation

The installation of fixed materials shall be under the general direction of the Owner/Designer in accordance with applicable specifications and layout drawings.

### 10.1 Preparation

Signage Contractor shall coordinate setting drawings, diagrams, templates, instructions and directions for the installation of items having integral anchors which are to be embedded in concrete. Signage Contractor shall coordinate delivery of such items to applicable trades for installation. Sign Contractor is also responsible for procuring any required signage or building permits, including obstruction permits that may be necessary while installing within city streets and public right-of-ways. Sign Contractor is responsible for coordinating with utility companies regarding the location of underground utilities prior to installation.

### 10.2 Delivery to Premise

Sign Contractor is responsible for securing staging and storage areas. Unless indicated to the contrary, items of loose material shall be delivered, uncrated, assembled, set in proper place and installed ready for use, free from breakage, blemishes or other defects.

### 10.3 Anchors and Inserts

Signage Contractor shall furnish inserts and anchoring devices which must be set in concrete or built into masonry for installation of this work, provide setting drawings, templates, instructions and directions for installation of anchorage devices and provide units with exposed surfaces matching the texture and finish of metal item anchored.

### 10.4 Cutting/Fitting/Placement

Signage Contractor shall perform all cutting, drilling and fitting required for installation, set work accurately in location, alignment and elevation, plumb, level and true, measured from established lines and levels, and provide temporary bracing or anchors as required.

Signage Contractor shall form tight joints with exposed connection accurately fitted with uniform reveals and spaces for sealants and joint fillers. Where cutting, welding and grinding are required for proper shop fitting and jointing of the work, Signage Contractor shall restore finishes to eliminate any evidence of corrective

work.

Signage Contractor shall not cut or abrade finishes which cannot be completely restored in field. Signage Contractor shall return items with such finishes to the shop for required alterations, followed by complete refinishing or providing new units at Signage Contractor option.

### 10.5 Erection

All surfaces shall be covered with protective non-deleterious to finish for protection until final installation or erection. Signage Contractor shall complete all connections in proper alignment and tighten bolts securely. Leveling is to be done only by instruments; measuring equal distances from existing surfaces will not be acceptable as a basis of level and/or plumb. After erection, all surfaces marred during erection and exposed bolts, bolt heads, etc., shall be retouched with same paint as previous.

### 10.6 Protective Coverings

Sign Contractor shall restore protective coverings which have been damaged during shipment or installation of the work, remove protection when requested for inspection of finishes and replace, retain protective coverings intact and remove simultaneously from similar finished items to preclude non-uniform oxidation and discoloration and remove protective coverings only when there is no possibility of damage from other work yet to be performed at the same location.

### 10.7 Cleaning of Premises/Signs

The Signage Contractor shall use special care in the disposition of excess materials and rubbish. Rubbish shall not be allowed to accumulate but shall be consistently collected and removed at the completion of this work, on a daily basis.

After installation, Signage Contractor shall clean soiled sign surfaces according to manufacturer's written instructions, Signage Contractor shall protect signs from damage until acceptance of Owner and shall touch up all nicks, scratches, fasteners that require color.

# A1 Kiosk - Pylon

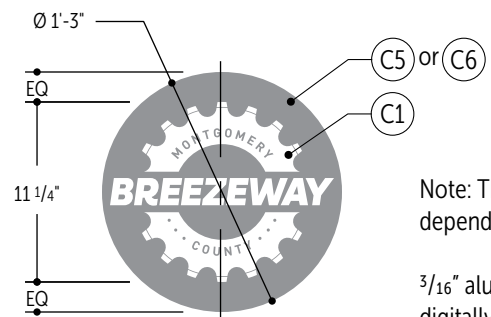

**TOPPER GRAPHIC LAYOUT**  
SCALE: 1" = 1'

Note: The logo and color is dependent on sign location

3/16" aluminum panels with digitally printed Bikeways or Breezeway logo on high-visibility prismatic reflective film

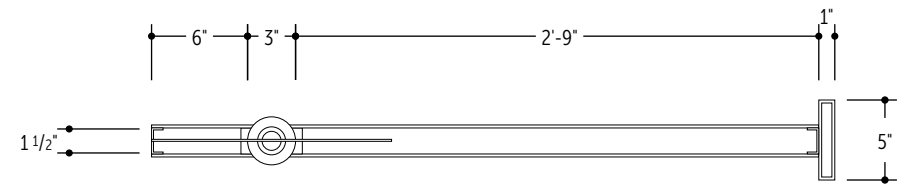

**1 TOP - DETAIL**  
SCALE: 1" = 1'

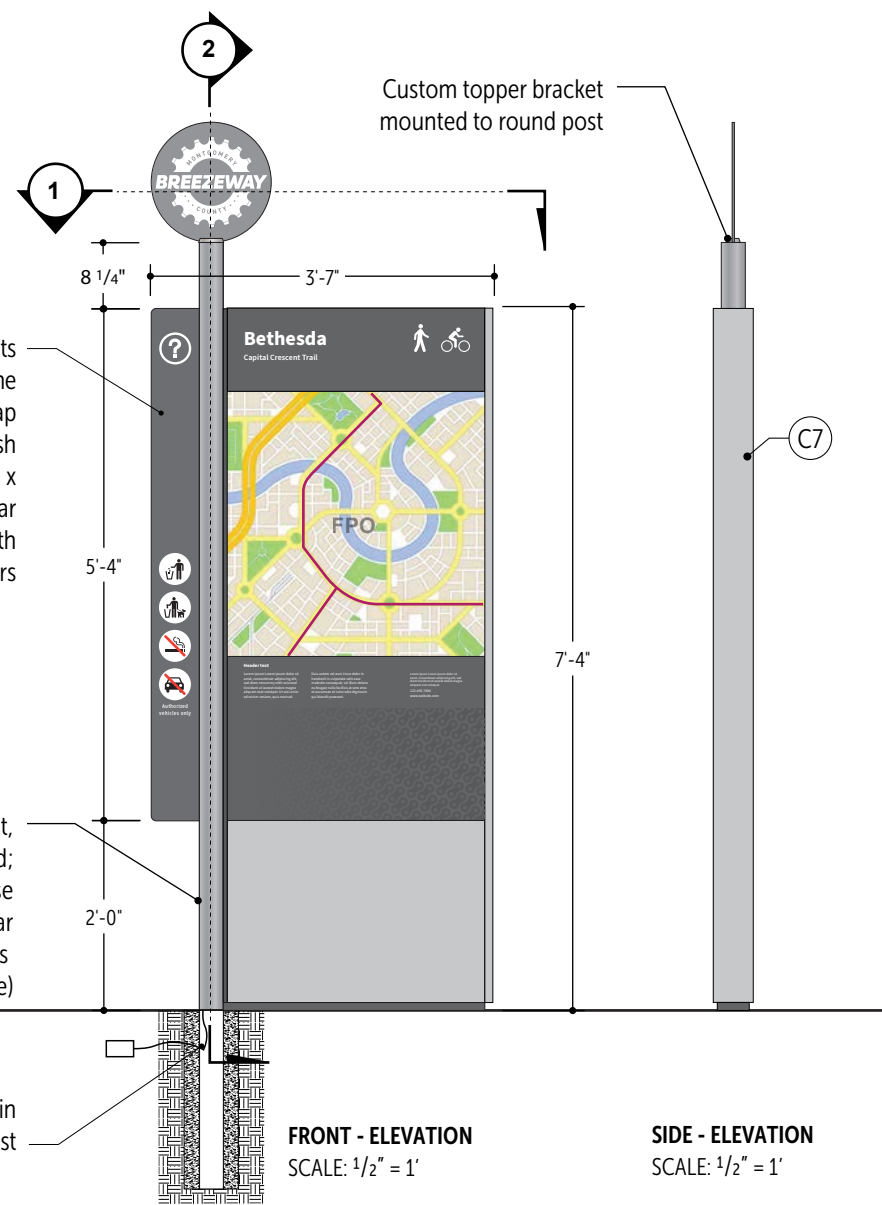

**FRONT - ELEVATION**  
SCALE: 1/2" = 1'

**SIDE - ELEVATION**  
SCALE: 1/2" = 1'

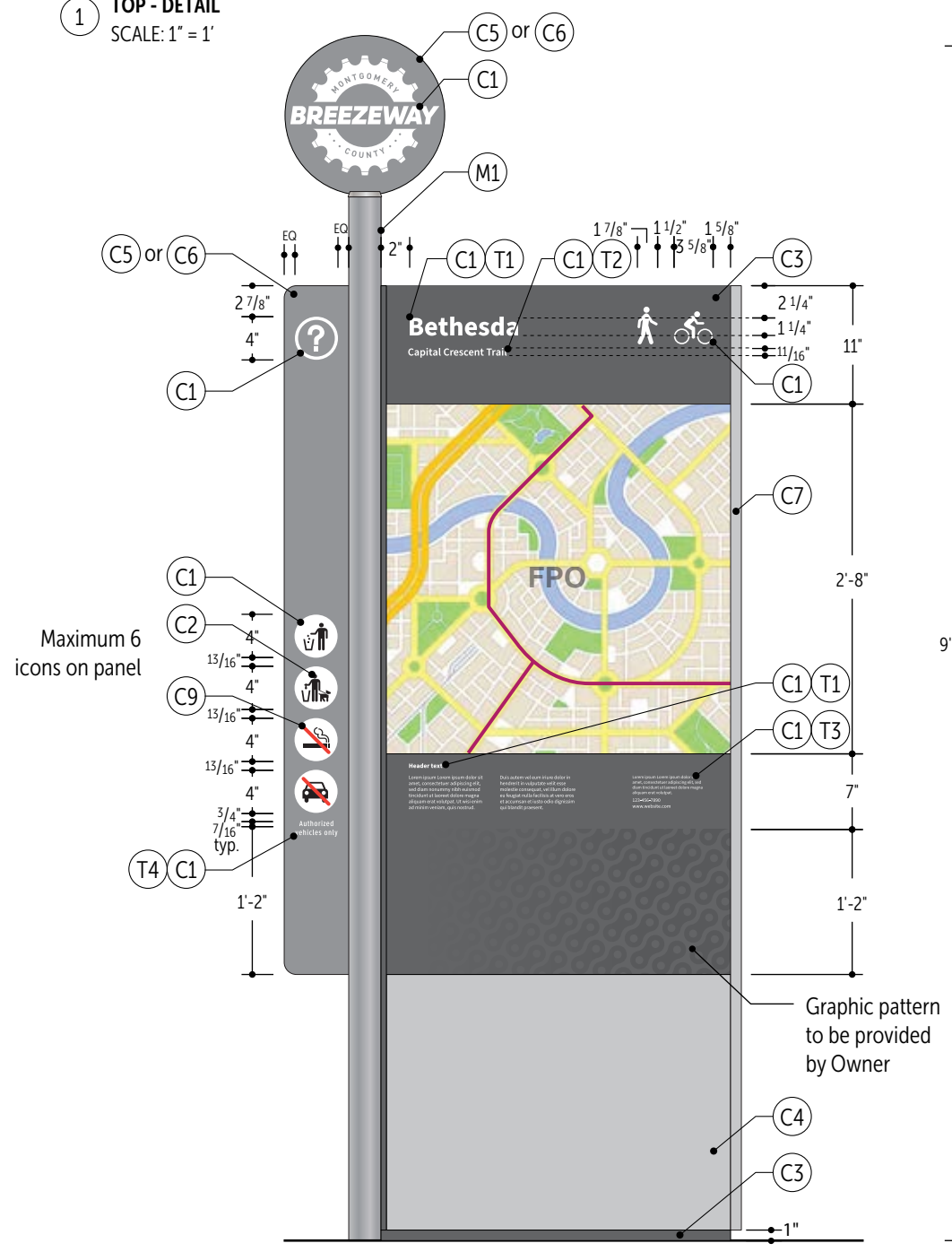

**TYPICAL KIOSK GRAPHIC LAYOUT**  
SCALE: 3/4" = 1'

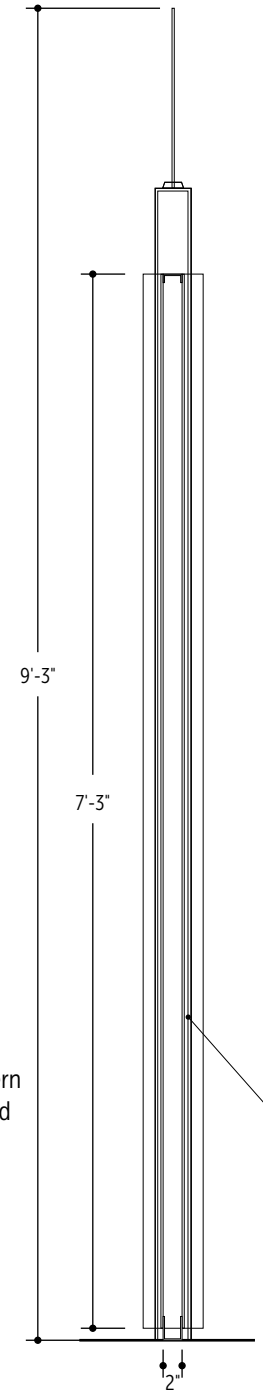

**2 SIDE - DETAIL**  
SCALE: 3/4" = 1'

**GENERAL NOTES**

Not For Construction – These drawings and notes are for the sole purpose of expressing visual design intent and are not intended for actual fabrication purposes. Sign Contractor accepts total responsibility for final material selection, fabrication and installation methods. Electronic files are not construction documents and cannot be relied upon as identical to construction documents because of changes or errors induced by translation, transmission, or alterations while under the control of others. Use of information contained in the electronic files is at the user's sole risk and without liability to Design Professional and its consultants. Refer to provided performance specifications for details on designer expectations of Fabricator and fabrication process. Copyright © Guide Studio, Inc. All rights reserved.

1. Sign contractor shall be responsible for design and engineering of supports, anchors and miscellaneous steel or metal required for installation.
2. The sign contractor's structural engineer shall be licensed in the state of the project and certify all connections and support details.
3. Isolate dissimilar materials as required.
4. Field dimensions shall be taken by the sign contractor prior to preparation of shop drawings and fabrication where possible. It is the responsibility of the sign contractor to site verify all sign locations for accuracy, fit, and potential obstacles. Sign contractor shall notify appropriate person(s) of any issues, discrepancies and potential obstacles per the attached Performance Specifications, contract, or specified communication process.
5. It is the responsibility of the sign contractor to contact appropriate services to verify locations of underground utilities.
6. Sign contractor must obtain all permits and field inspection approvals necessary to complete work per city requirements. All sign locations need to be located and staked by sign contractor and approved by the Bikeways Coordinator at the Montgomery County Department of Transportation prior to installation.
7. Sign contractor shall follow any additional requirements presented in the Performance Specifications.

Aluminum sign cabinet mounted to post with aluminum bracket Engineering as needed

# A2 Kiosk - Post & Panel

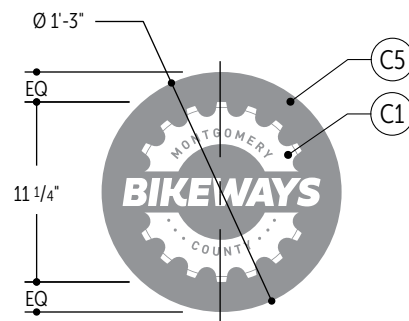

TOPPER GRAPHIC LAYOUT  
SCALE: 1" = 1'

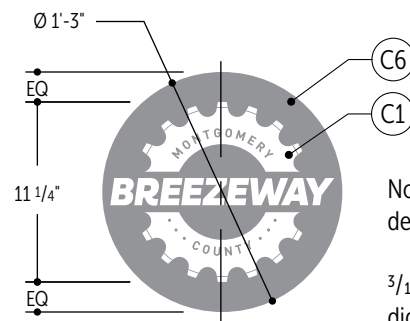

Note: The logo and color is dependent on sign location

3/16" aluminum panels with digitally printed Bikeways or Breezeaway logo on high-visibility prismatic reflective film

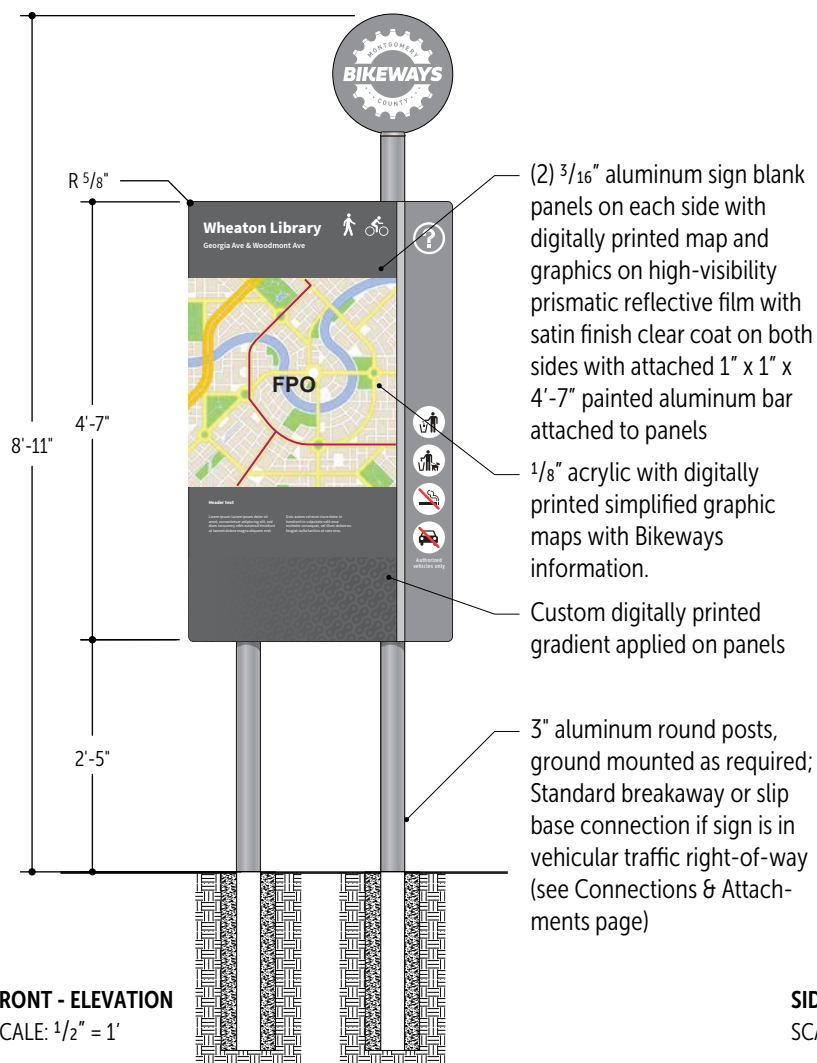

FRONT - ELEVATION  
SCALE: 1/2" = 1'

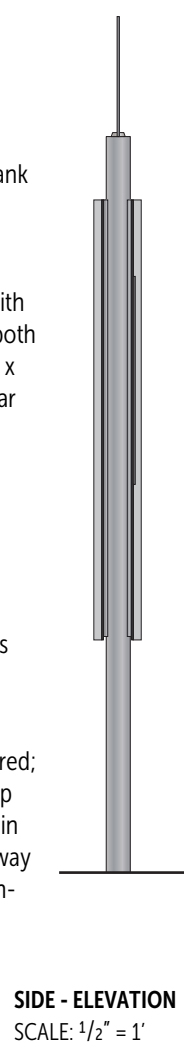

SIDE - ELEVATION  
SCALE: 1/2" = 1'



ANGLED - RENDERING  
SCALE: 1/2" = 1'

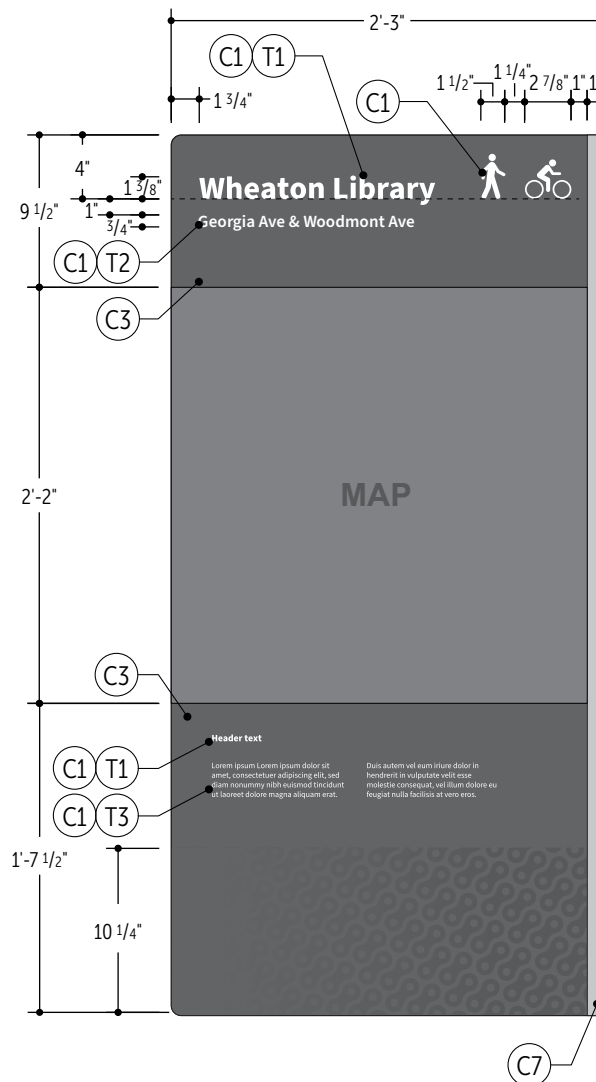

TYPICAL KIOSK GRAPHIC LAYOUTS  
SCALE: 1" = 1'

Custom topper bracket mounted to round post, engineering as needed

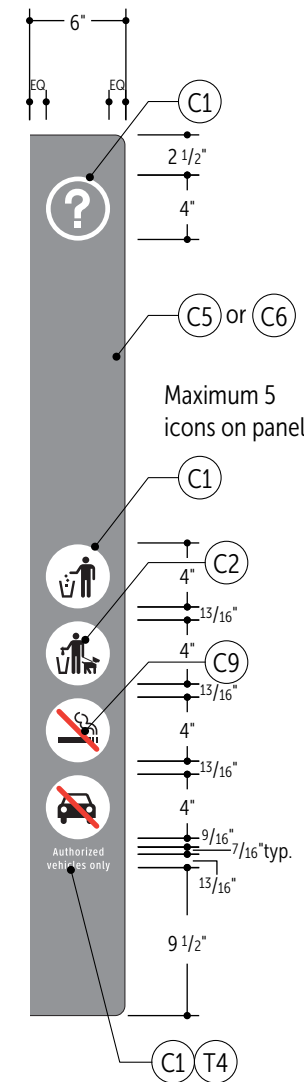

BACKSIDE OF BACK PANEL

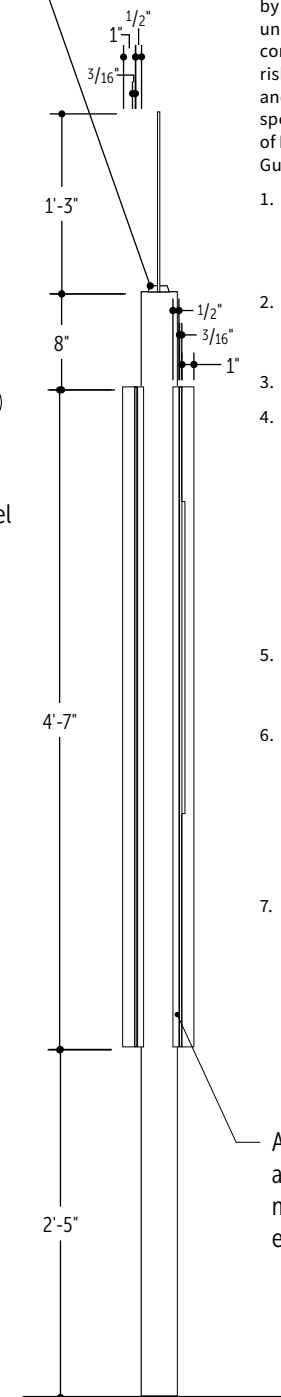

SIDE - DETAIL  
SCALE: 3/4" = 1'

GENERAL NOTES

Not For Construction - These drawings and notes are for the sole purpose of expressing visual design intent and are not intended for actual fabrication purposes. Sign Contractor accepts total responsibility for final material selection, fabrication and installation methods. Electronic files are not construction documents and cannot be relied upon as identical to construction documents because of changes or errors induced by translation, transmission, or alterations while under the control of others. Use of information contained in the electronic files is at the user's sole risk and without liability to Design Professional and its consultants. Refer to provided performance specifications for details on designer expectations of Fabricator and fabrication process. Copyright © Guide Studio, Inc. All rights reserved.

1. Sign contractor shall be responsible for design and engineering of supports, anchors and miscellaneous steel or metal required for installation.
2. The sign contractor's structural engineer shall be licensed in the state of the project and certify all connections and support details.
3. Isolate dissimilar materials as required.
4. Field dimensions shall be taken by the sign contractor prior to preparation of shop drawings and fabrication where possible. It is the responsibility of the sign contractor to site verify all sign locations for accuracy, fit, and potential obstacles. Sign contractor shall notify appropriate person(s) of any issues, discrepancies and potential obstacles per the attached Performance Specifications, contract, or specified communication process.
5. It is the responsibility of the sign contractor to contact appropriate services to verify locations of underground utilities.
6. Sign contractor must obtain all permits and field inspection approvals necessary to complete work per city requirements. All sign locations need to be located and staked by sign contractor and approved by the Bikeways Coordinator at the Montgomery County Department of Transportation prior to installation.
7. Sign contractor shall follow any additional requirements presented in the Performance Specifications.

Aluminum channel support attached to sign panel and mounted onto posts, engineering as needed

# B1 Directional

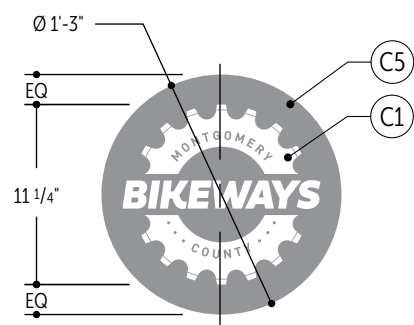

TOPPER GRAPHIC LAYOUT  
SCALE: 1" = 1'

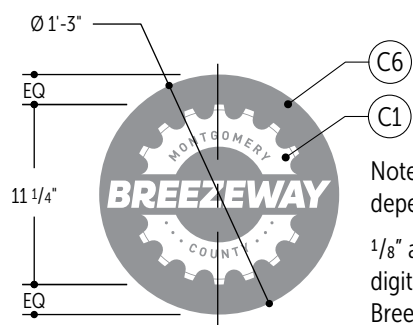

Note: The logo and color is dependent on sign location  
1/8" aluminum panels with digitally printed Bikeways or Breezeway logo on high-visibility prismatic reflective film

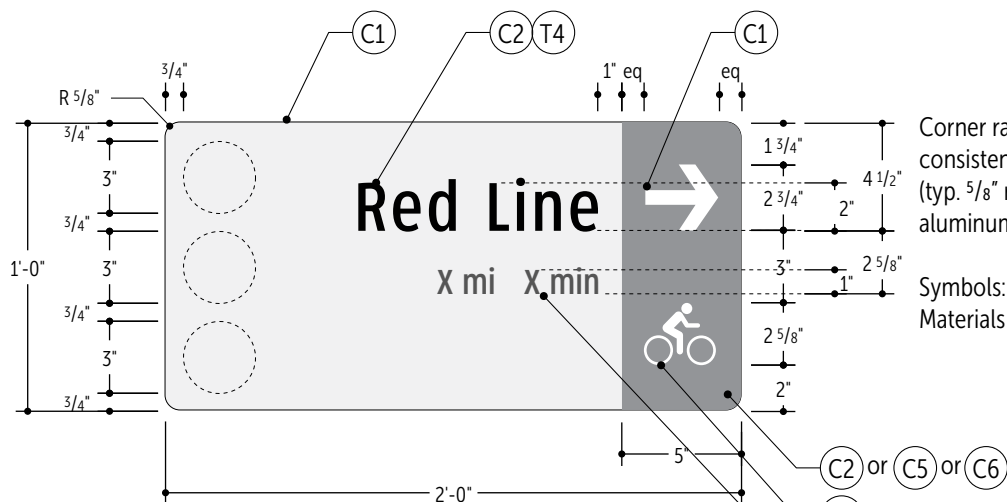

TYPICAL DESTINATION DIRECTIONAL GRAPHIC LAYOUT  
SCALE: 1 1/2" = 1'

Corner radius are to be consistent per each sign type, (typ. 5/8" radius corners on aluminum sign blanks).

Symbols: See the Colors & Materials page

GENERAL NOTES

Not For Construction – These drawings and notes are for the sole purpose of expressing visual design intent and are not intended for actual fabrication purposes. Sign Contractor accepts total responsibility for final material selection, fabrication and installation methods. Electronic files are not construction documents and cannot be relied upon as identical to construction documents because of changes or errors induced by translation, transmission, or alterations while under the control of others. Use of information contained in the electronic files is at the user's sole risk and without liability to Design Professional and its consultants. Refer to provided performance specifications for details on designer expectations of Fabricator and fabrication process. Copyright © Guide Studio, Inc. All rights reserved.

1. Sign contractor shall be responsible for design and engineering of supports, anchors and miscellaneous steel or metal required for installation.
2. The sign contractor's structural engineer shall be licensed in the state of the project and certify all connections and support details.
3. Isolate dissimilar materials as required.
4. Field dimensions shall be taken by the sign contractor prior to preparation of shop drawings and fabrication where possible. It is the responsibility of the sign contractor to site verify all sign locations for accuracy, fit, and potential obstacles. Sign contractor shall notify appropriate person(s) of any issues, discrepancies and potential obstacles per the attached Performance Specifications, contract, or specified communication process.
5. It is the responsibility of the sign contractor to contact appropriate services to verify locations of underground utilities.
6. Sign contractor must obtain all permits and field inspection approvals necessary to complete work per city requirements. All sign locations need to be located and staked by sign contractor and approved by the Bikeways Coordinator at the Montgomery County Department of Transportation prior to installation.

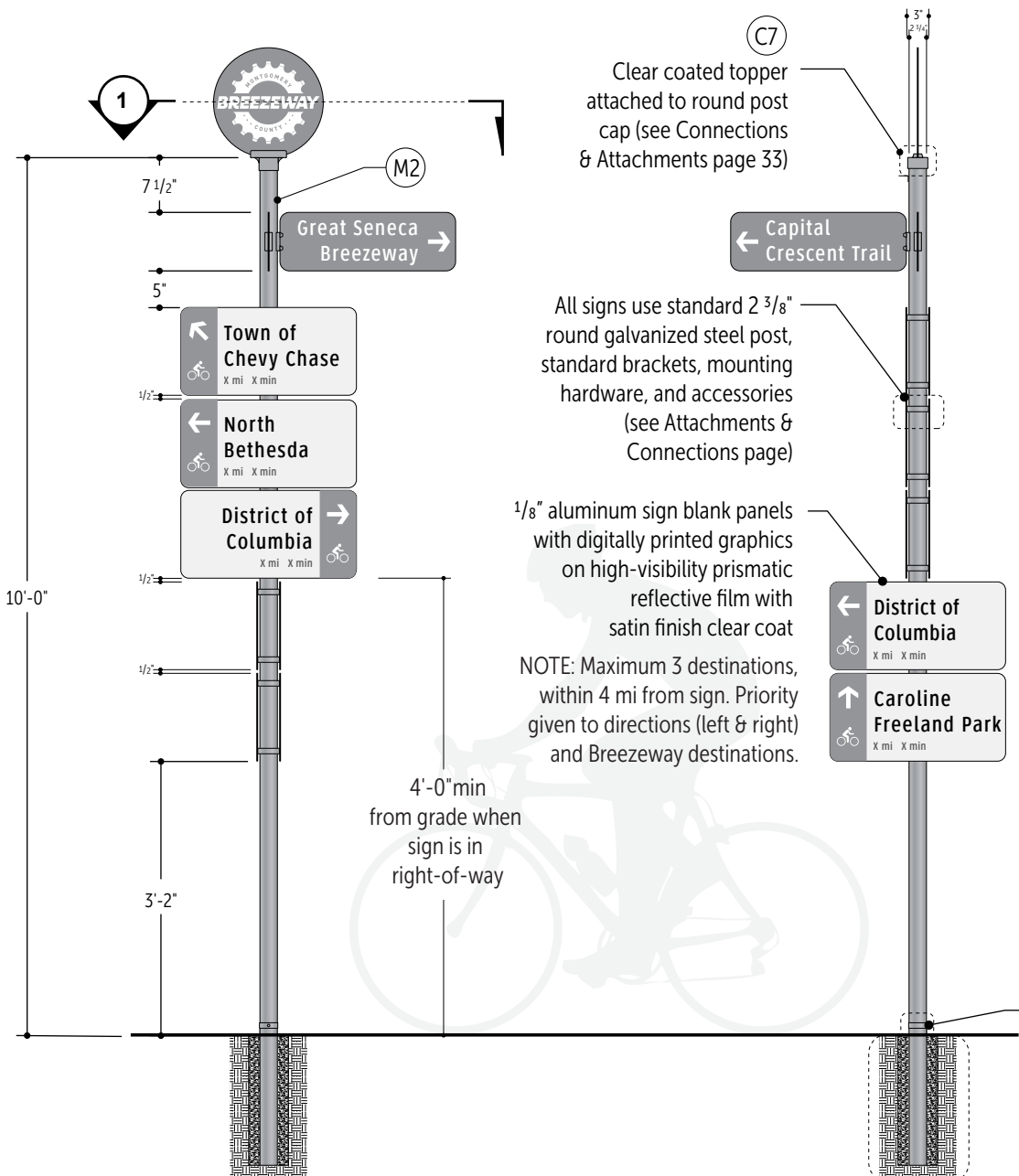

SIDE 1 - ELEVATION  
SCALE: 1/2" = 1'

SIDE 2 - ELEVATION  
SCALE: 1/2" = 1'

Clear coated topper attached to round post cap (see Connections & Attachments page 33)

All signs use standard 2 3/8" round galvanized steel post, standard brackets, mounting hardware, and accessories (see Attachments & Connections page)

1/8" aluminum sign blank panels with digitally printed graphics on high-visibility prismatic reflective film with satin finish clear coat

NOTE: Maximum 3 destinations, within 4 mi from sign. Priority given to directions (left & right) and Breezeway destinations.

4'-0" min from grade when sign is in right-of-way

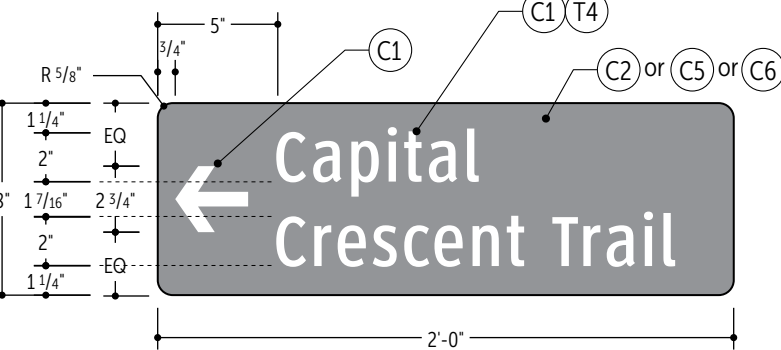

TYPICAL CROSS-ROUTE DIRECTIONAL GRAPHIC LAYOUT  
SCALE: 1-1/2" = 1'

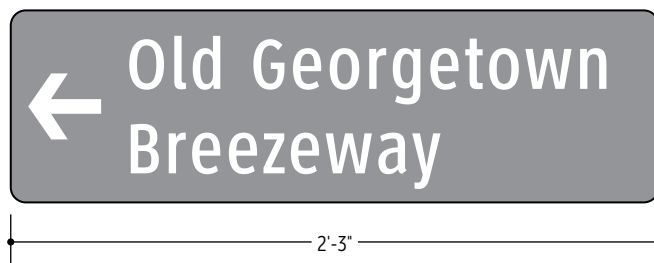

ALTERNATE CROSS-ROUTE DIRECTIONAL (FOR LONGER MESSAGES)  
SCALE: 1-1/2" = 1'

For messages that do not fit on the standard panel size, a longer panel may be used (all other dimensions remain the same)

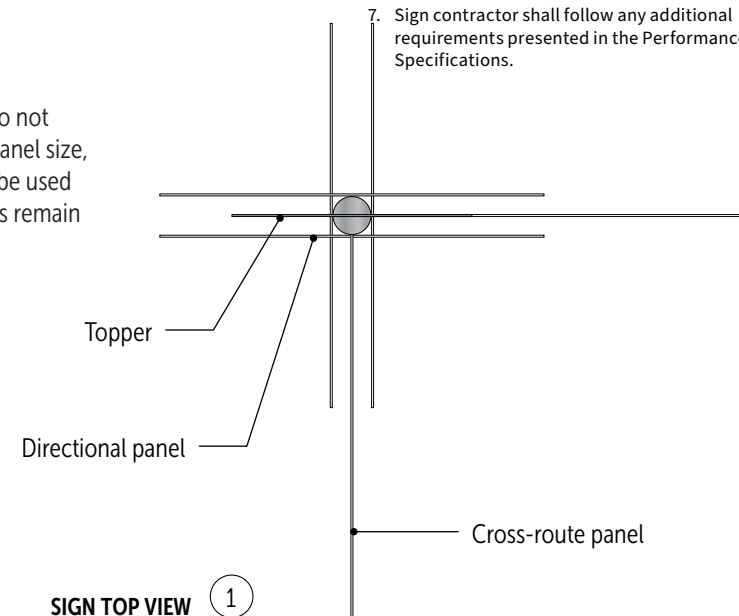

SIGN TOP VIEW  
SCALE: 1 1/2" = 1'

Standard breakaway or slip base connection if sign is in vehicular traffic right-of-way (see Connections & Attachments page)

# B2 Trailblazer

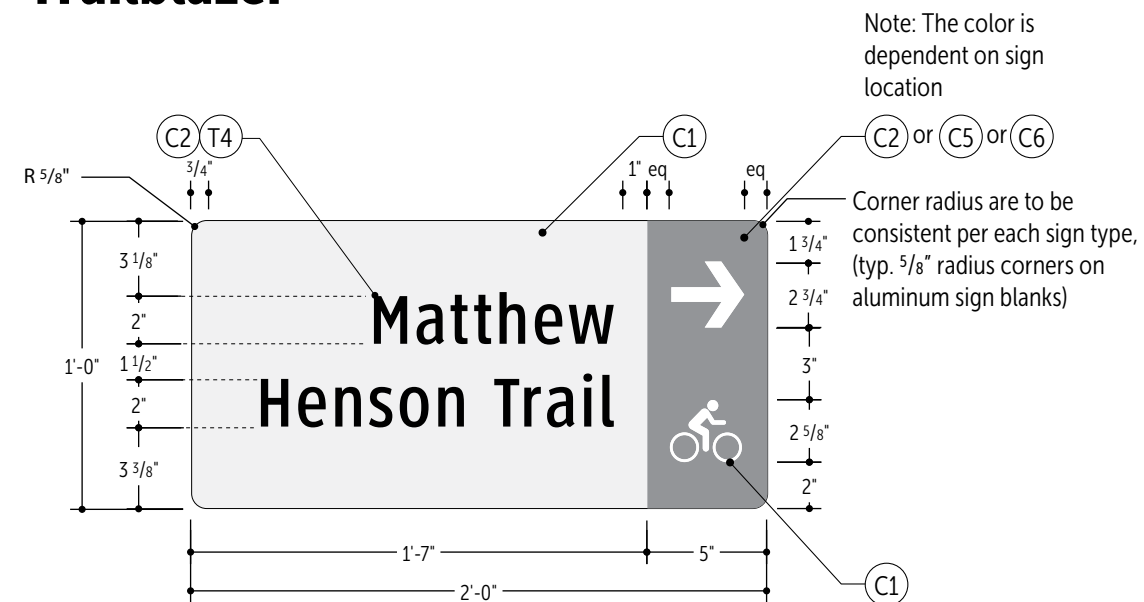

**TYPICAL DESTINATION TRAILBLAZER DIRECTIONAL GRAPHIC LAYOUT**  
SCALE: 1 1/2" = 1'

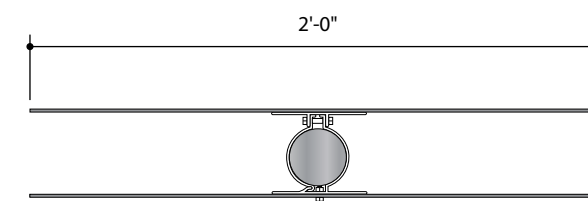

**1 TOP VIEW - TRAILBLAZER DIRECTIONAL GRAPHIC**  
SCALE: 1/2" = 1'

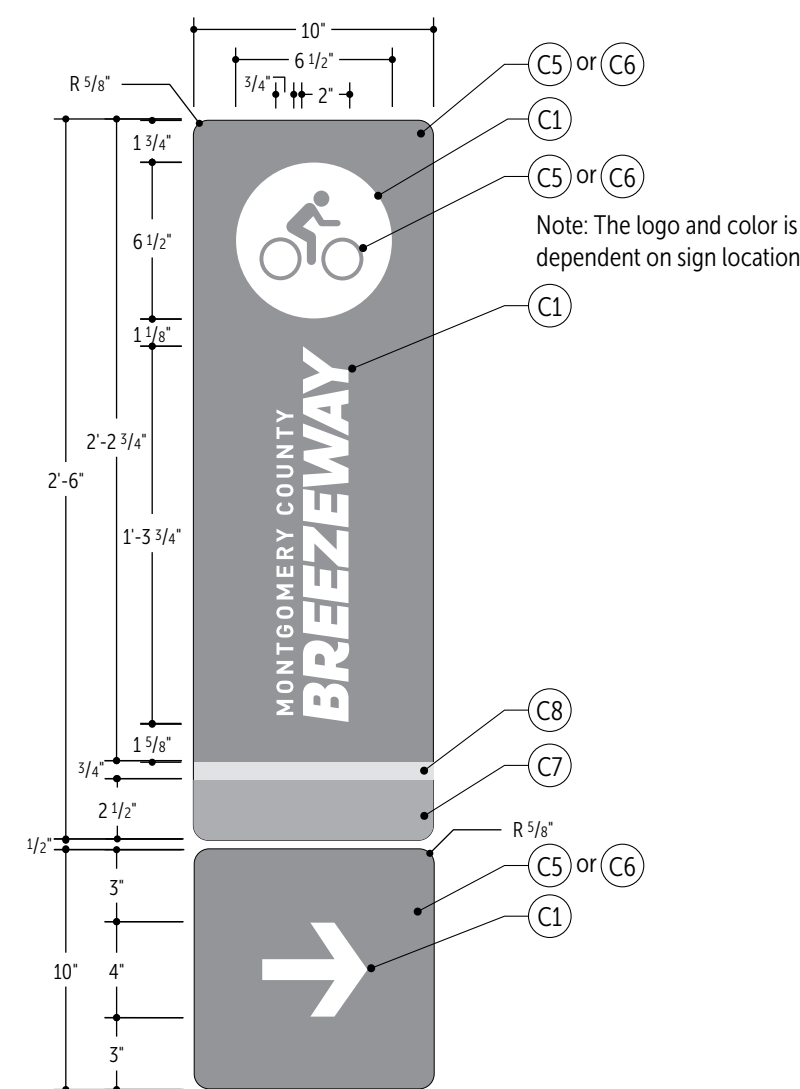

**TYPICAL DESTINATION TRAILBLAZER ID GRAPHIC LAYOUT**  
SCALE: 1 1/2" = 1'

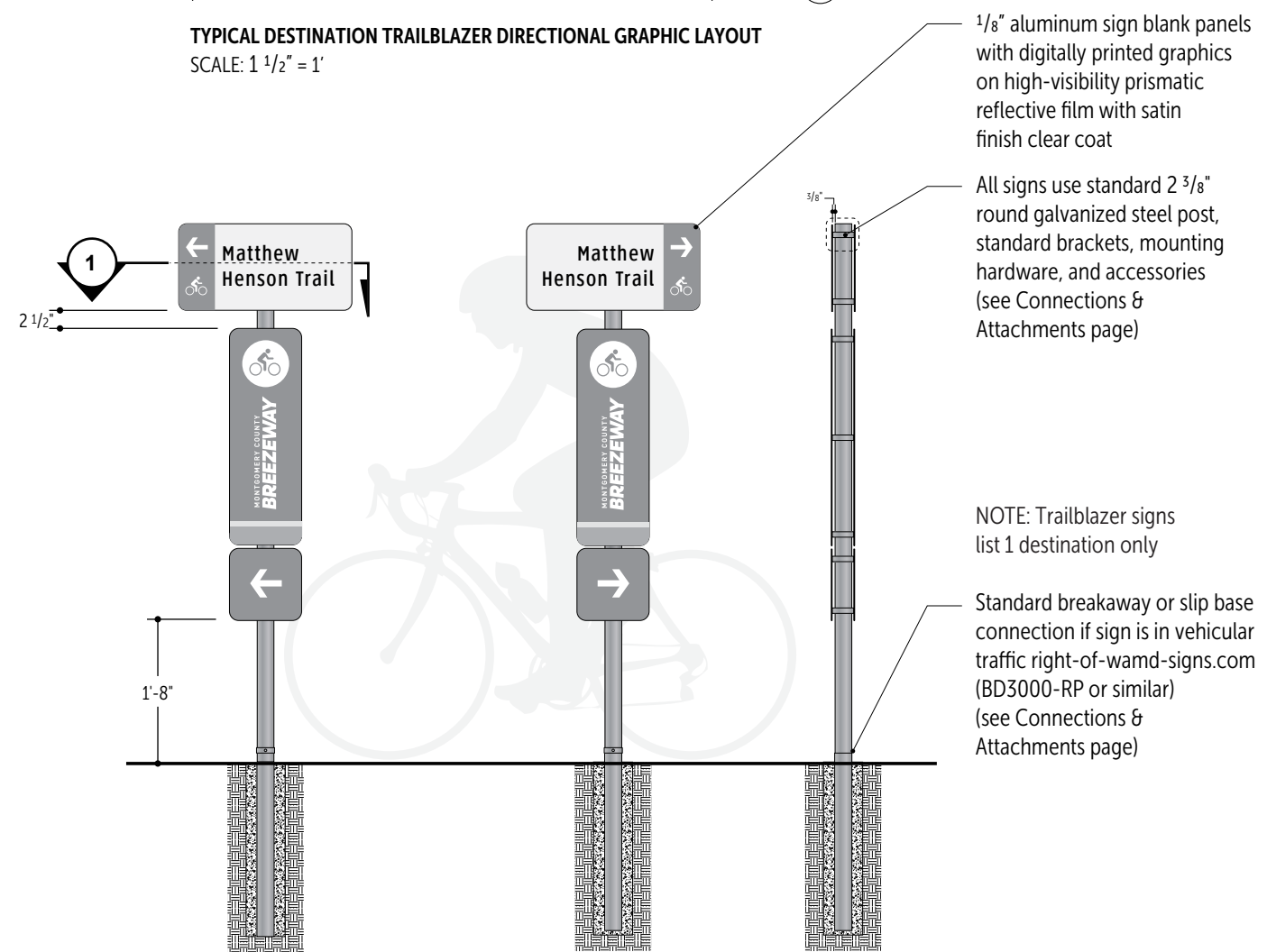

**FRONT 1 - ELEVATION**  
SCALE: 1/2" = 1'

**FRONT 2 - ELEVATION**  
SCALE: 1/2" = 1'

**SIDE - ELEVATION**  
SCALE: 1/2" = 1'

Note: The color is dependent on sign location  
Corner radius are to be consistent per each sign type, (typ. 5/8" radius corners on aluminum sign blanks)

1/8" aluminum sign blank panels with digitally printed graphics on high-visibility prismatic reflective film with satin finish clear coat

All signs use standard 2 3/8" round galvanized steel post, standard brackets, mounting hardware, and accessories (see Connections & Attachments page)

NOTE: Trailblazer signs list 1 destination only

Standard breakaway or slip base connection if sign is in vehicular traffic right-of-way (see Connections & Attachments page)

**GENERAL NOTES**

Not For Construction – These drawings and notes are for the sole purpose of expressing visual design intent and are not intended for actual fabrication purposes. Sign Contractor accepts total responsibility for final material selection, fabrication and installation methods. Electronic files are not construction documents and cannot be relied upon as identical to construction documents because of changes or errors induced by translation, transmission, or alterations while under the control of others. Use of information contained in the electronic files is at the user's sole risk and without liability to Design Professional and its consultants. Refer to provided performance specifications for details on designer expectations of Fabricator and fabrication process. Copyright © Guide Studio, Inc. All rights reserved.

1. Sign contractor shall be responsible for design and engineering of supports, anchors and miscellaneous steel or metal required for installation.
2. The sign contractor's structural engineer shall be licensed in the state of the project and certify all connections and support details.
3. Isolate dissimilar materials as required.
4. Field dimensions shall be taken by the sign contractor prior to preparation of shop drawings and fabrication where possible. It is the responsibility of the sign contractor to site verify all sign locations for accuracy, fit, and potential obstacles. Sign contractor shall notify appropriate person(s) of any issues, discrepancies and potential obstacles per the attached Performance Specifications, contract, or specified communication process.
5. It is the responsibility of the sign contractor to contact appropriate services to verify locations of underground utilities.
6. Sign contractor must obtain all permits and field inspection approvals necessary to complete work per city requirements. All sign locations need to be located and staked by sign contractor and approved by the Bikeways Coordinator at the Montgomery County Department of Transportation prior to installation.
7. Sign contractor shall follow any additional requirements presented in the Performance Specifications.

# B3 Route Marker

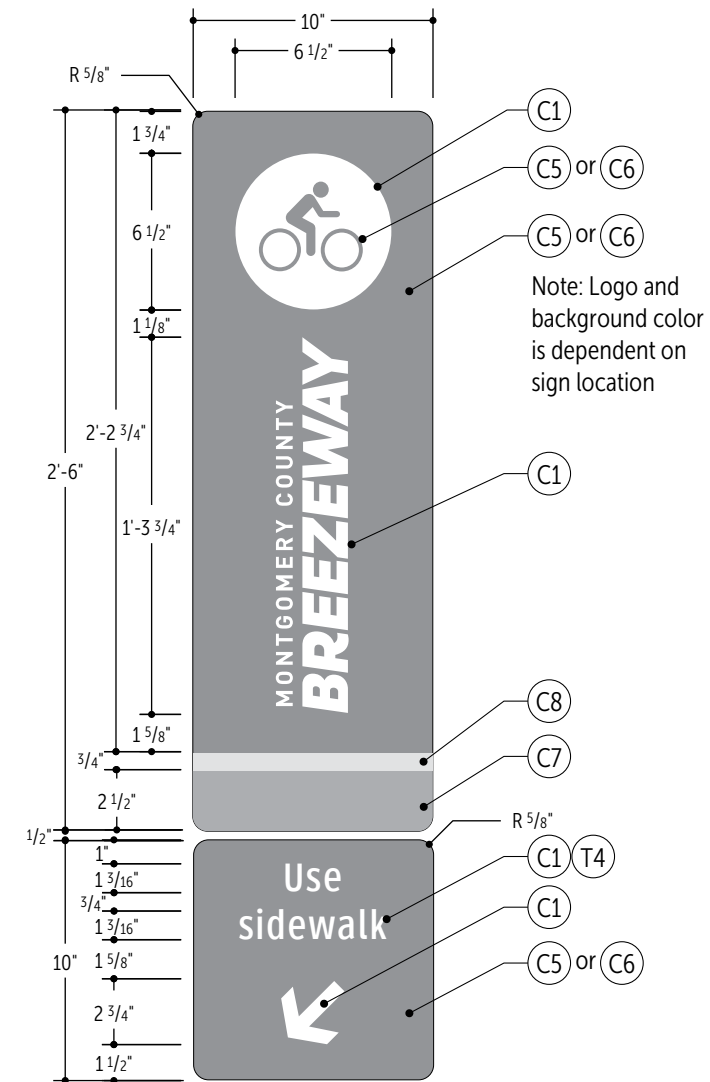
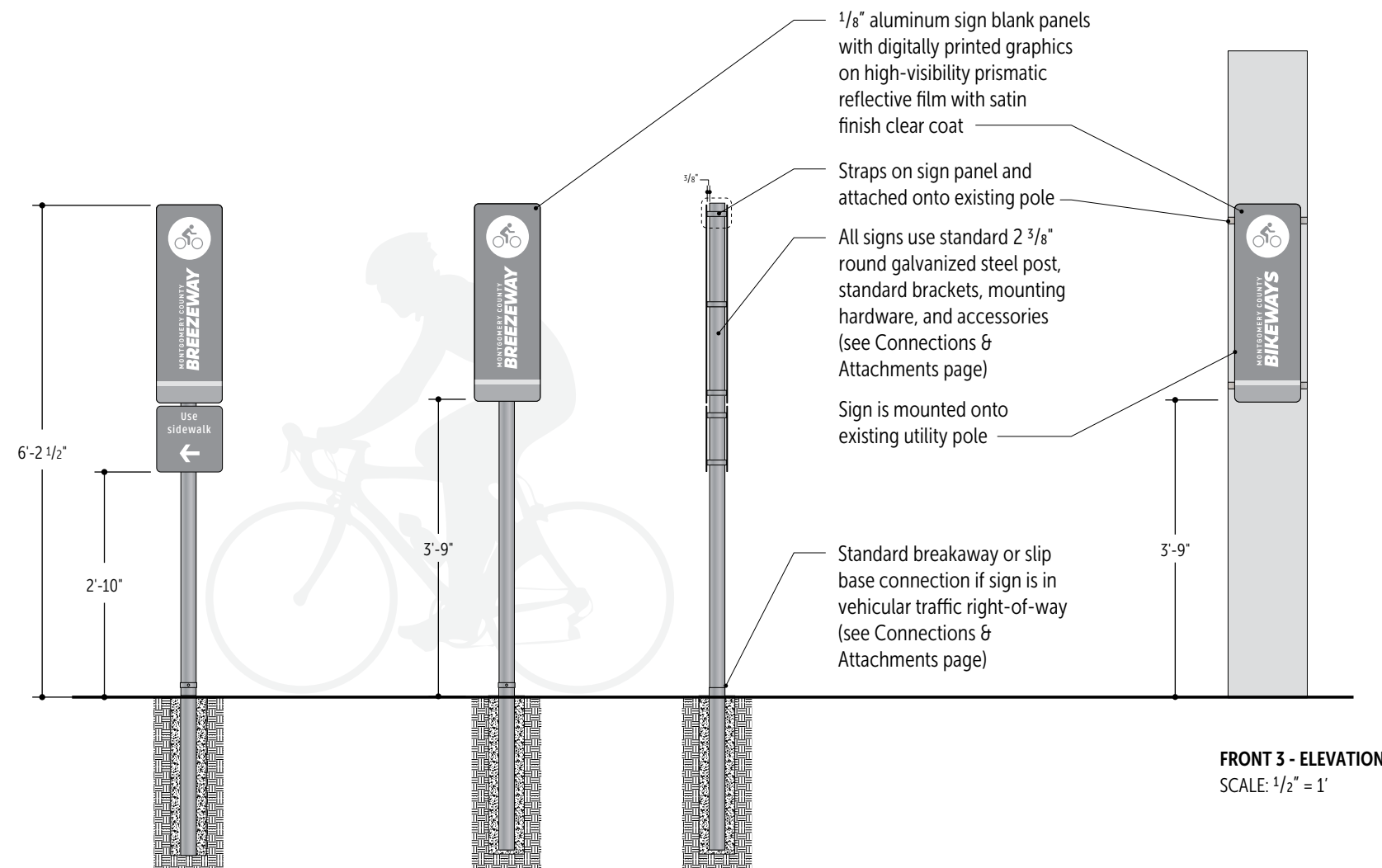

**GENERAL NOTES**

Not For Construction – These drawings and notes are for the sole purpose of expressing visual design intent and are not intended for actual fabrication purposes. Sign Contractor accepts total responsibility for final material selection, fabrication and installation methods. Electronic files are not construction documents and cannot be relied upon as identical to construction documents because of changes or errors induced by translation, transmission, or alterations while under the control of others. Use of information contained in the electronic files is at the user's sole risk and without liability to Design Professional and its consultants. Refer to provided performance specifications for details on designer expectations of Fabricator and fabrication process. Copyright © Guide Studio, Inc. All rights reserved.

1. Sign contractor shall be responsible for design and engineering of supports, anchors and miscellaneous steel or metal required for installation.
2. The sign contractor's structural engineer shall be licensed in the state of the project and certify all connections and support details.
3. Isolate dissimilar materials as required.
4. Field dimensions shall be taken by the sign contractor prior to preparation of shop drawings and fabrication where possible. It is the responsibility of the sign contractor to site verify all sign locations for accuracy, fit, and potential obstacles. Sign contractor shall notify appropriate person(s) of any issues, discrepancies and potential obstacles per the attached Performance Specifications, contract, or specified communication process.
5. It is the responsibility of the sign contractor to contact appropriate services to verify locations of underground utilities.
6. Sign contractor must obtain all permits and field inspection approvals necessary to complete work per city requirements. All sign locations need to be located and staked by sign contractor and approved by the Bikeways Coordinator at the Montgomery County Department of Transportation prior to installation.
7. Sign contractor shall follow any additional requirements presented in the Performance Specifications.

## B4 Pavement Marking

### ROUTE MARKER PAVEMENT MARKING

NOTE: Text and graphic details reduced to maximize legibility.

Removing "Bikeways" from right example would be more DOT acceptable.

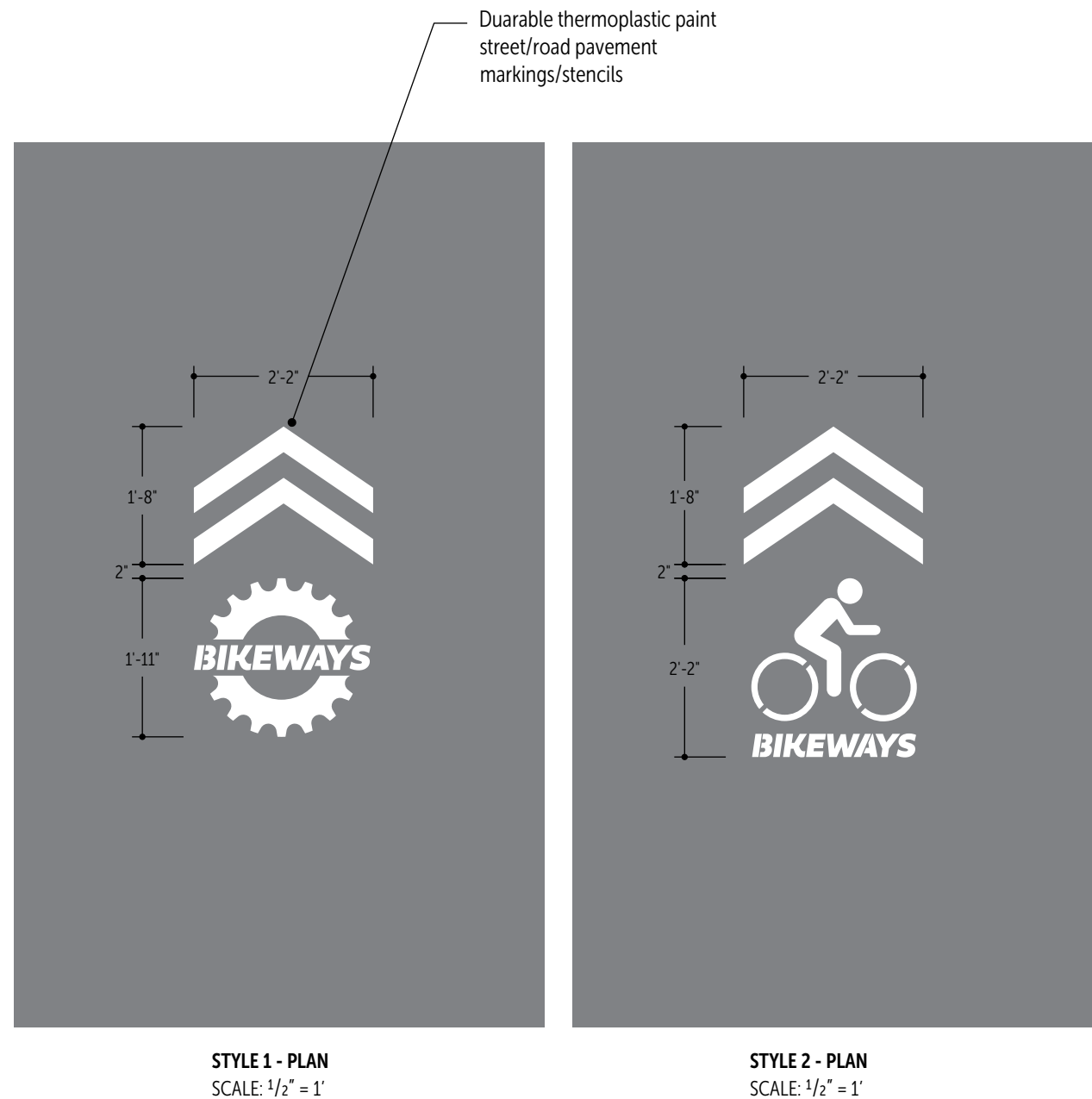

NOTE: Sizing may need to be adjusted based on size of road/lane/path. Do not alter proportions.

#### GENERAL NOTES

Not For Construction – These drawings and notes are for the sole purpose of expressing visual design intent and are not intended for actual fabrication purposes. Sign Contractor accepts total responsibility for final material selection, fabrication and installation methods. Electronic files are not construction documents and cannot be relied upon as identical to construction documents because of changes or errors induced by translation, transmission, or alterations while under the control of others. Use of information contained in the electronic files is at the user's sole risk and without liability to Design Professional and its consultants. Refer to provided performance specifications for details on designer expectations of Fabricator and fabrication process. Copyright © Guide Studio, Inc. All rights reserved.

1. Sign contractor shall be responsible for design and engineering of supports, anchors and miscellaneous steel or metal required for installation.
2. The sign contractor's structural engineer shall be licensed in the state of the project and certify all connections and support details.
3. Isolate dissimilar materials as required.
4. Field dimensions shall be taken by the sign contractor prior to preparation of shop drawings and fabrication where possible. It is the responsibility of the sign contractor to site verify all sign locations for accuracy, fit, and potential obstacles. Sign contractor shall notify appropriate person(s) of any issues, discrepancies and potential obstacles per the attached Performance Specifications, contract, or specified communication process.
5. It is the responsibility of the sign contractor to contact appropriate services to verify locations of underground utilities.
6. Sign contractor must obtain all permits and field inspection approvals necessary to complete work per city requirements. All sign locations need to be located and staked by sign contractor and approved by the Bikeways Coordinator at the Montgomery County Department of Transportation prior to installation.
7. Sign contractor shall follow any additional requirements presented in the Performance Specifications.

# C1 Amenity/Service Identification

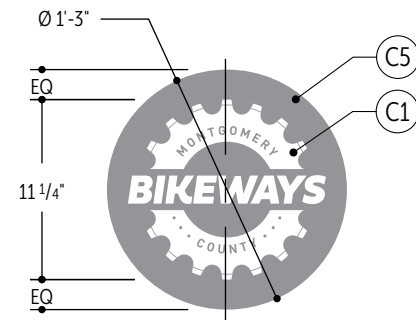

**TOPPER GRAPHIC LAYOUT**  
SCALE: 1" = 1'

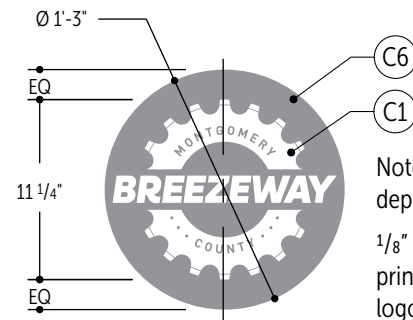

Note: The logo and color is dependent on sign location

1/8" aluminum panels with digitally printed Bikeways or Breezeway logo on high-visibility prismatic reflective film for attachments see Connections & Attachments (page 33), engineering as needed

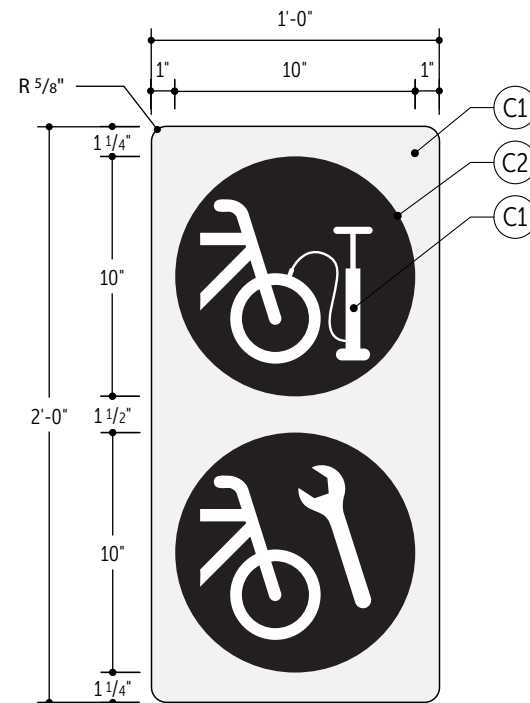
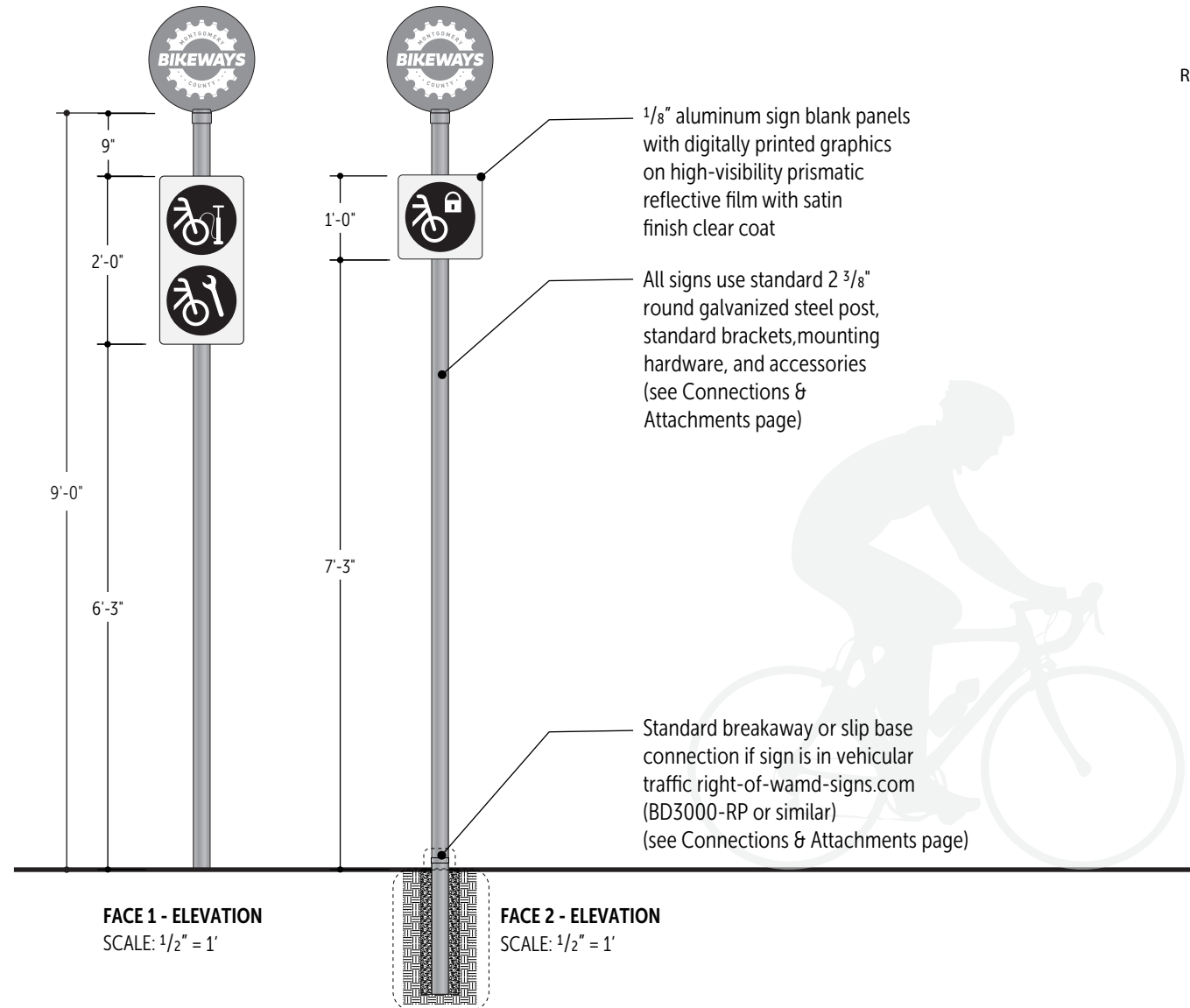

**FACE 1 - SYMBOL PANEL LAYOUT**  
SCALE: 1 1/2" = 1'

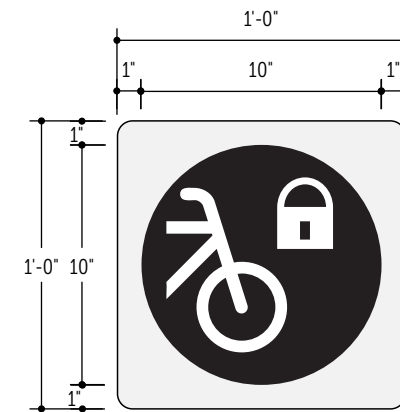

**FACE 2 - SYMBOL PANEL LAYOUT**  
SCALE: 1 1/2" = 1'

**GENERAL NOTES**

Not For Construction – These drawings and notes are for the sole purpose of expressing visual design intent and are not intended for actual fabrication purposes. Sign Contractor accepts total responsibility for final material selection, fabrication and installation methods. Electronic files are not construction documents and cannot be relied upon as identical to construction documents because of changes or errors induced by translation, transmission, or alterations while under the control of others. Use of information contained in the electronic files is at the user's sole risk and without liability to Design Professional and its consultants. Refer to provided performance specifications for details on designer expectations of Fabricator and fabrication process. Copyright © Guide Studio, Inc. All rights reserved.

1. Sign contractor shall be responsible for design and engineering of supports, anchors and miscellaneous steel or metal required for installation.
2. The sign contractor's structural engineer shall be licensed in the state of the project and certify all connections and support details.
3. Isolate dissimilar materials as required.
4. Field dimensions shall be taken by the sign contractor prior to preparation of shop drawings and fabrication where possible. It is the responsibility of the sign contractor to site verify all sign locations for accuracy, fit, and potential obstacles. Sign contractor shall notify appropriate person(s) of any issues, discrepancies and potential obstacles per the attached Performance Specifications, contract, or specified communication process.
5. It is the responsibility of the sign contractor to contact appropriate services to verify locations of underground utilities.
6. Sign contractor must obtain all permits and field inspection approvals necessary to complete work per city requirements. All sign locations need to be located and staked by sign contractor and approved by the Bikeways Coordinator at the Montgomery County Department of Transportation prior to installation.
7. Sign contractor shall follow any additional requirements presented in the Performance Specifications.



## C2 Street Sign Topper Identification

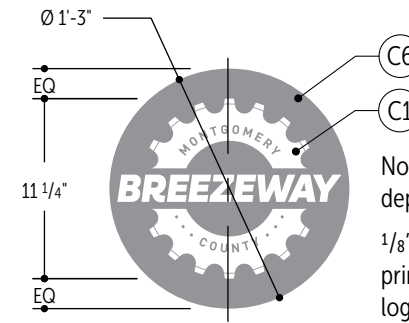
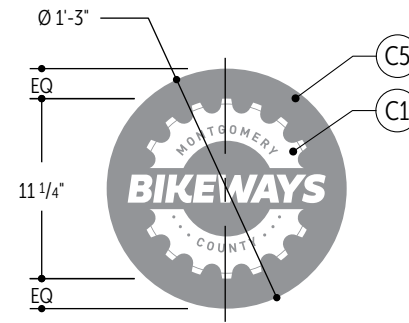

Note: The logo and color is dependent on sign location  
 1/8" aluminum panels with digitally printed Bikeways or Breezeway logo on high-visibility prismatic reflective film for attachments (see Connections & Attachments page), engineering as needed

TOPPER GRAPHIC LAYOUT  
 SCALE: 1" = 1'

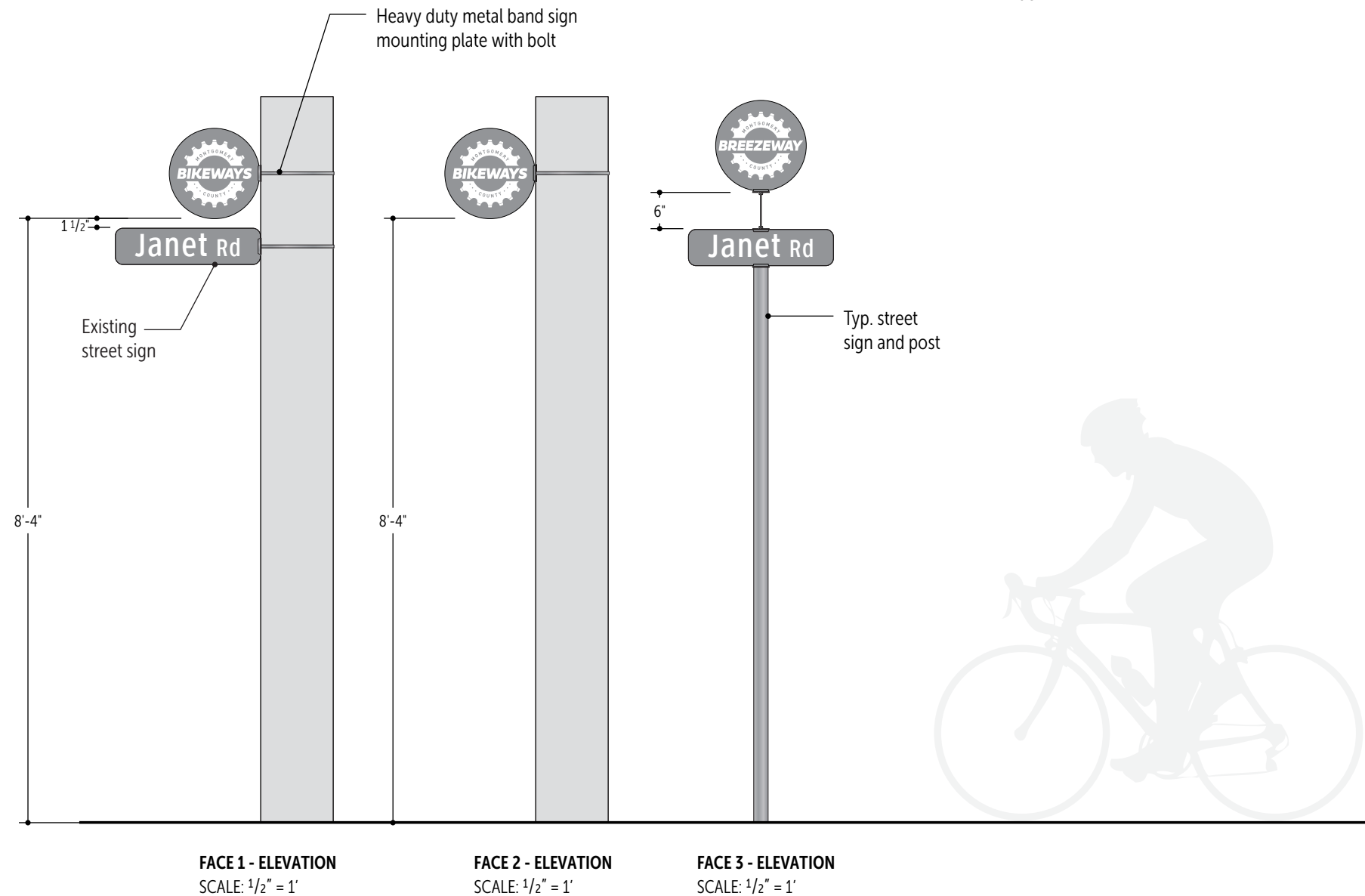

**GENERAL NOTES**

Not For Construction – These drawings and notes are for the sole purpose of expressing visual design intent and are not intended for actual fabrication purposes. Sign Contractor accepts total responsibility for final material selection, fabrication and installation methods. Electronic files are not construction documents and cannot be relied upon as identical to construction documents because of changes or errors induced by translation, transmission, or alterations while under the control of others. Use of information contained in the electronic files is at the user's sole risk and without liability to Design Professional and its consultants. Refer to provided performance specifications for details on designer expectations of Fabricator and fabrication process. Copyright © Guide Studio, Inc. All rights reserved.

1. Sign contractor shall be responsible for design and engineering of supports, anchors and miscellaneous steel or metal required for installation.
2. The sign contractor's structural engineer shall be licensed in the state of the project and certify all connections and support details.
3. Isolate dissimilar materials as required.
4. Field dimensions shall be taken by the sign contractor prior to preparation of shop drawings and fabrication where possible. It is the responsibility of the sign contractor to site verify all sign locations for accuracy, fit, and potential obstacles. Sign contractor shall notify appropriate person(s) of any issues, discrepancies and potential obstacles per the attached Performance Specifications, contract, or specified communication process.
5. It is the responsibility of the sign contractor to contact appropriate services to verify locations of underground utilities.
6. Sign contractor must obtain all permits and field inspection approvals necessary to complete work per city requirements. All sign locations need to be located and staked by sign contractor and approved by the Bikeways Coordinator at the Montgomery County Department of Transportation prior to installation.
7. Sign contractor shall follow any additional requirements presented in the Performance Specifications.

# C3 Jurisdiction Identification

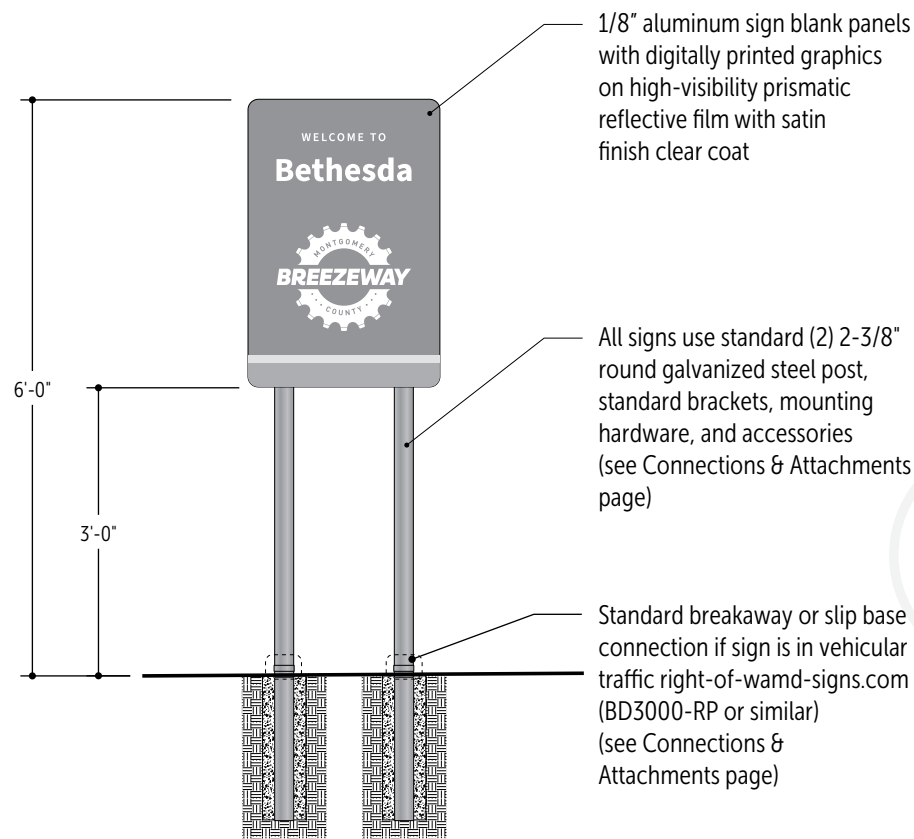

**FRONT 1 - ELEVATION**  
SCALE: 1/2" = 1'

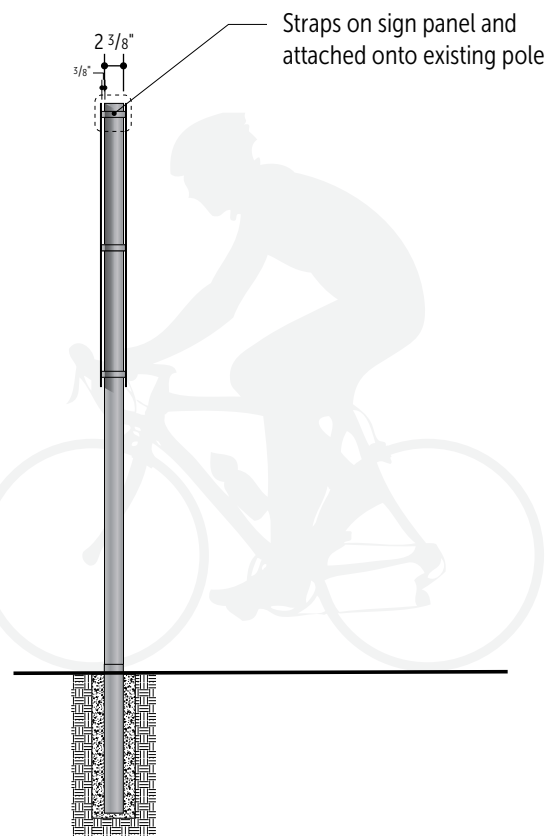

**SIDE 1 - ELEVATION**  
SCALE: 1/2" = 1'

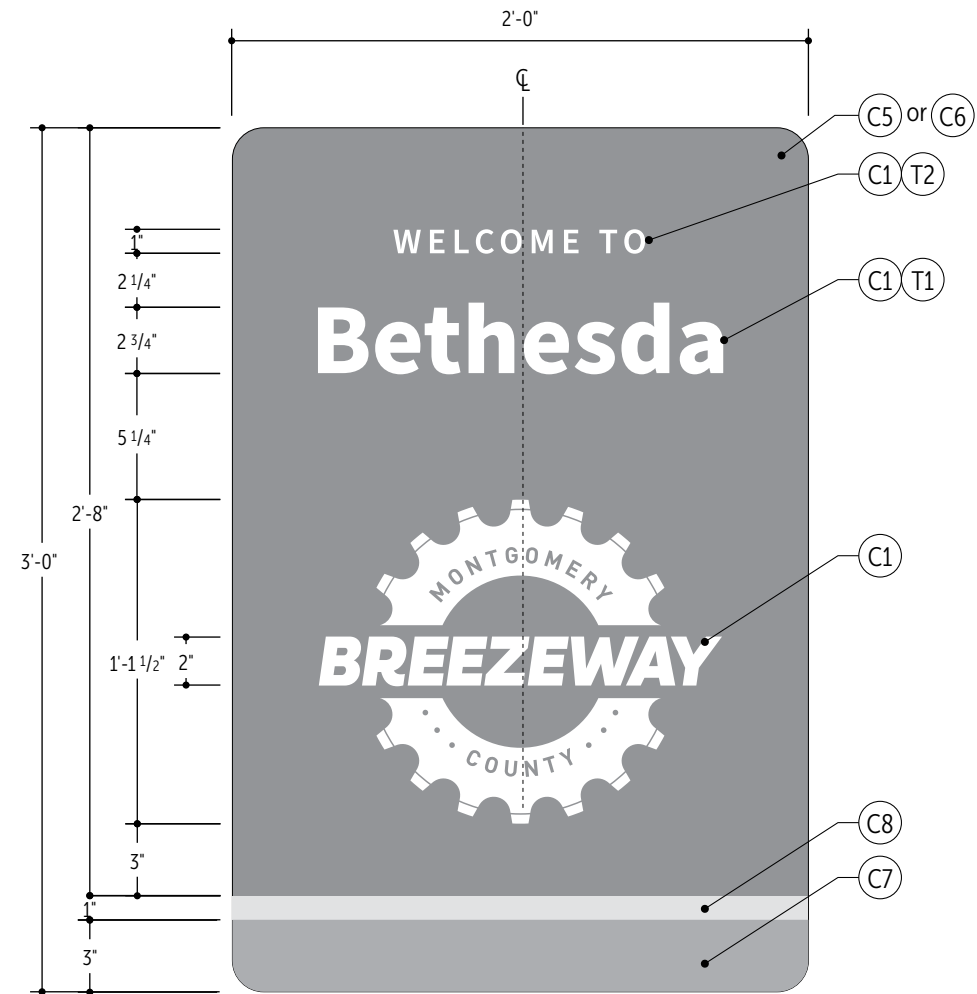

**TYPICAL JURISDICTION ID GRAPHIC LAYOUT**  
SCALE: 1-1/2" = 1'

**GENERAL NOTES**

Not For Construction – These drawings and notes are for the sole purpose of expressing visual design intent and are not intended for actual fabrication purposes. Sign Contractor accepts total responsibility for final material selection, fabrication and installation methods. Electronic files are not construction documents and cannot be relied upon as identical to construction documents because of changes or errors induced by translation, transmission, or alterations while under the control of others. Use of information contained in the electronic files is at the user's sole risk and without liability to Design Professional and its consultants. Refer to provided performance specifications for details on designer expectations of Fabricator and fabrication process. Copyright © Guide Studio, Inc. All rights reserved.

1. Sign contractor shall be responsible for design and engineering of supports, anchors and miscellaneous steel or metal required for installation.
2. The sign contractor's structural engineer shall be licensed in the state of the project and certify all connections and support details.
3. Isolate dissimilar materials as required.
4. Field dimensions shall be taken by the sign contractor prior to preparation of shop drawings and fabrication where possible. It is the responsibility of the sign contractor to site verify all sign locations for accuracy, fit, and potential obstacles. Sign contractor shall notify appropriate person(s) of any issues, discrepancies and potential obstacles per the attached Performance Specifications, contract, or specified communication process.
5. It is the responsibility of the sign contractor to contact appropriate services to verify locations of underground utilities.
6. Sign contractor must obtain all permits and field inspection approvals necessary to complete work per city requirements. All sign locations need to be located and staked by sign contractor and approved by the Bikeways Coordinator at the Montgomery County Department of Transportation prior to installation.
7. Sign contractor shall follow any additional requirements presented in the Performance Specifications.

# D1 Regulatory Custom Message

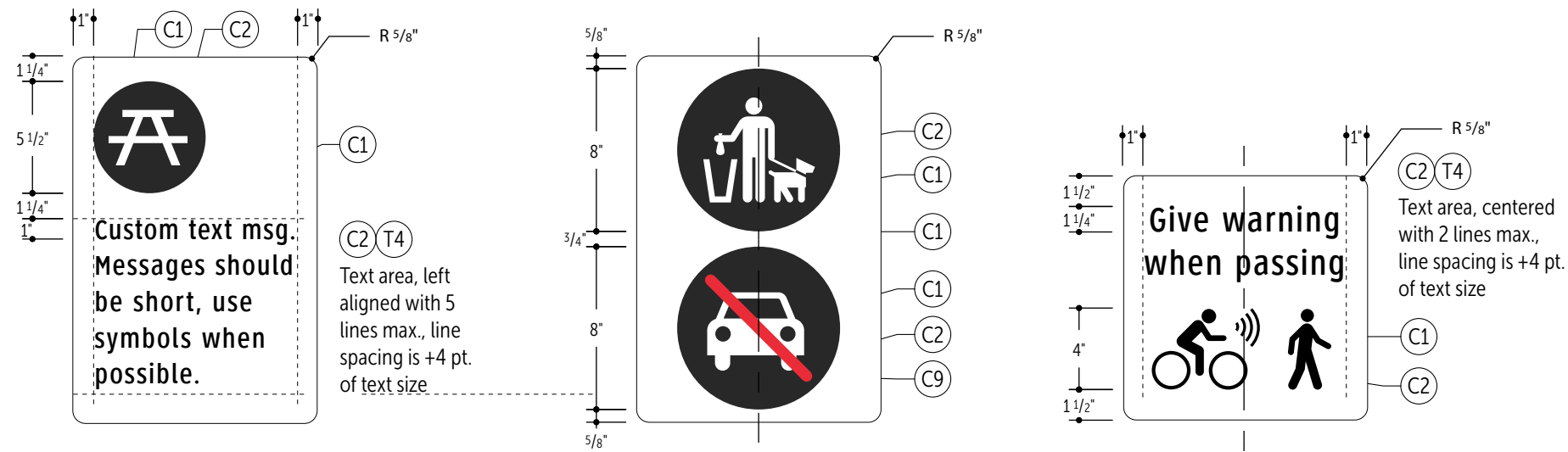

**PANEL LAYOUT OPTIONS DETAILS**  
SCALE: 1 1/2" = 1'

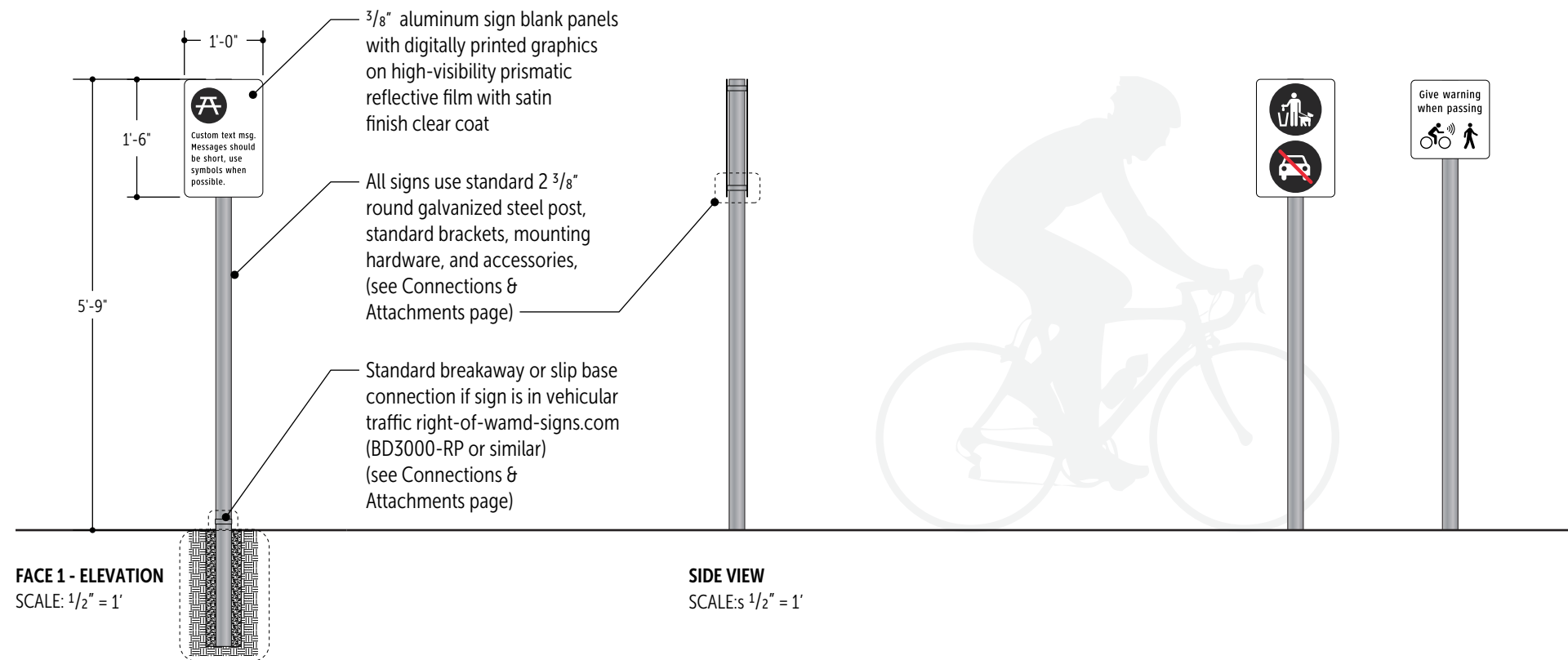

**GENERAL NOTES**

Not For Construction – These drawings and notes are for the sole purpose of expressing visual design intent and are not intended for actual fabrication purposes. Sign Contractor accepts total responsibility for final material selection, fabrication and installation methods. Electronic files are not construction documents and cannot be relied upon as identical to construction documents because of changes or errors induced by translation, transmission, or alterations while under the control of others. Use of information contained in the electronic files is at the user's sole risk and without liability to Design Professional and its consultants. Refer to provided performance specifications for details on designer expectations of Fabricator and fabrication process. Copyright © Guide Studio, Inc. All rights reserved.

1. Sign contractor shall be responsible for design and engineering of supports, anchors and miscellaneous steel or metal required for installation.
2. The sign contractor's structural engineer shall be licensed in the state of the project and certify all connections and support details.
3. Isolate dissimilar materials as required.
4. Field dimensions shall be taken by the sign contractor prior to preparation of shop drawings and fabrication where possible. It is the responsibility of the sign contractor to site verify all sign locations for accuracy, fit, and potential obstacles. Sign contractor shall notify appropriate person(s) of any issues, discrepancies and potential obstacles per the attached Performance Specifications, contract, or specified communication process.
5. It is the responsibility of the sign contractor to contact appropriate services to verify locations of underground utilities.
6. Sign contractor must obtain all permits and field inspection approvals necessary to complete work per city requirements. All sign locations need to be located and staked by sign contractor and approved by the Bikeways Coordinator at the Montgomery County Department of Transportation prior to installation.
7. Sign contractor shall follow any additional requirements presented in the Performance Specifications.

## D2 Regulatory Rules

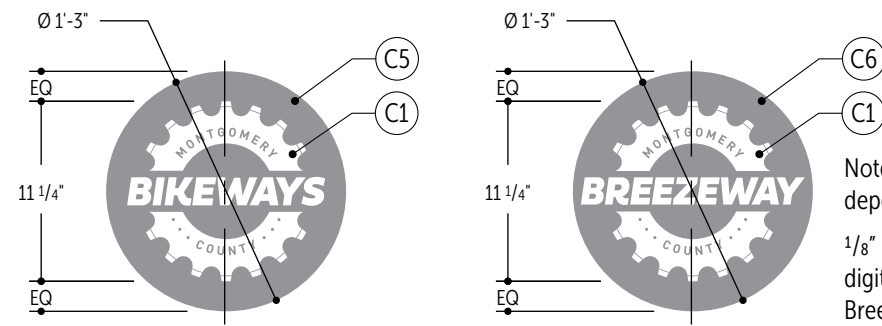

**TOPPER GRAPHIC LAYOUT**  
SCALE: 1" = 1'

Note: The logo and color is dependent on sign location

1/8" aluminum panels with digitally printed Bikeways or Breezeway logo on high-visibility prismatic reflective film

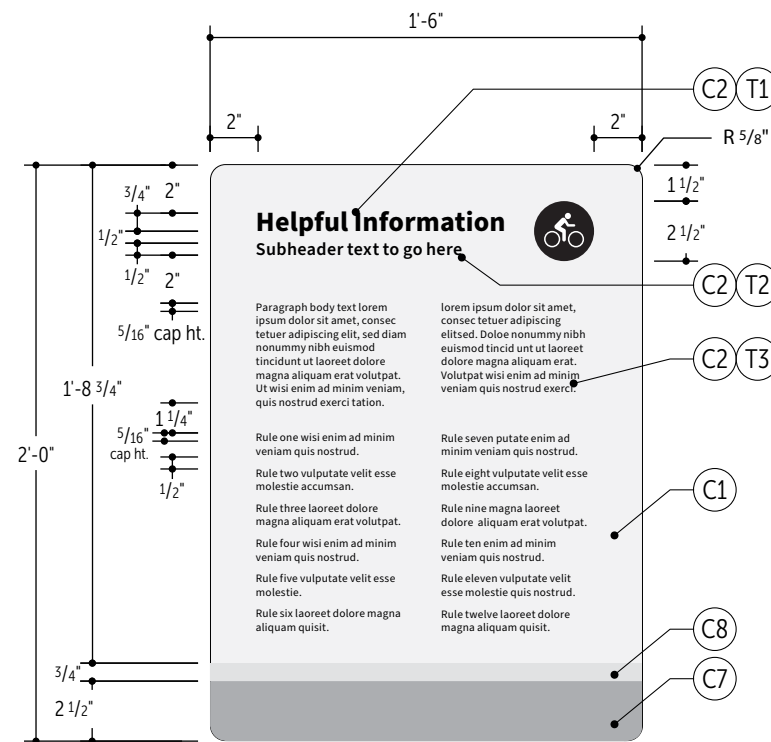
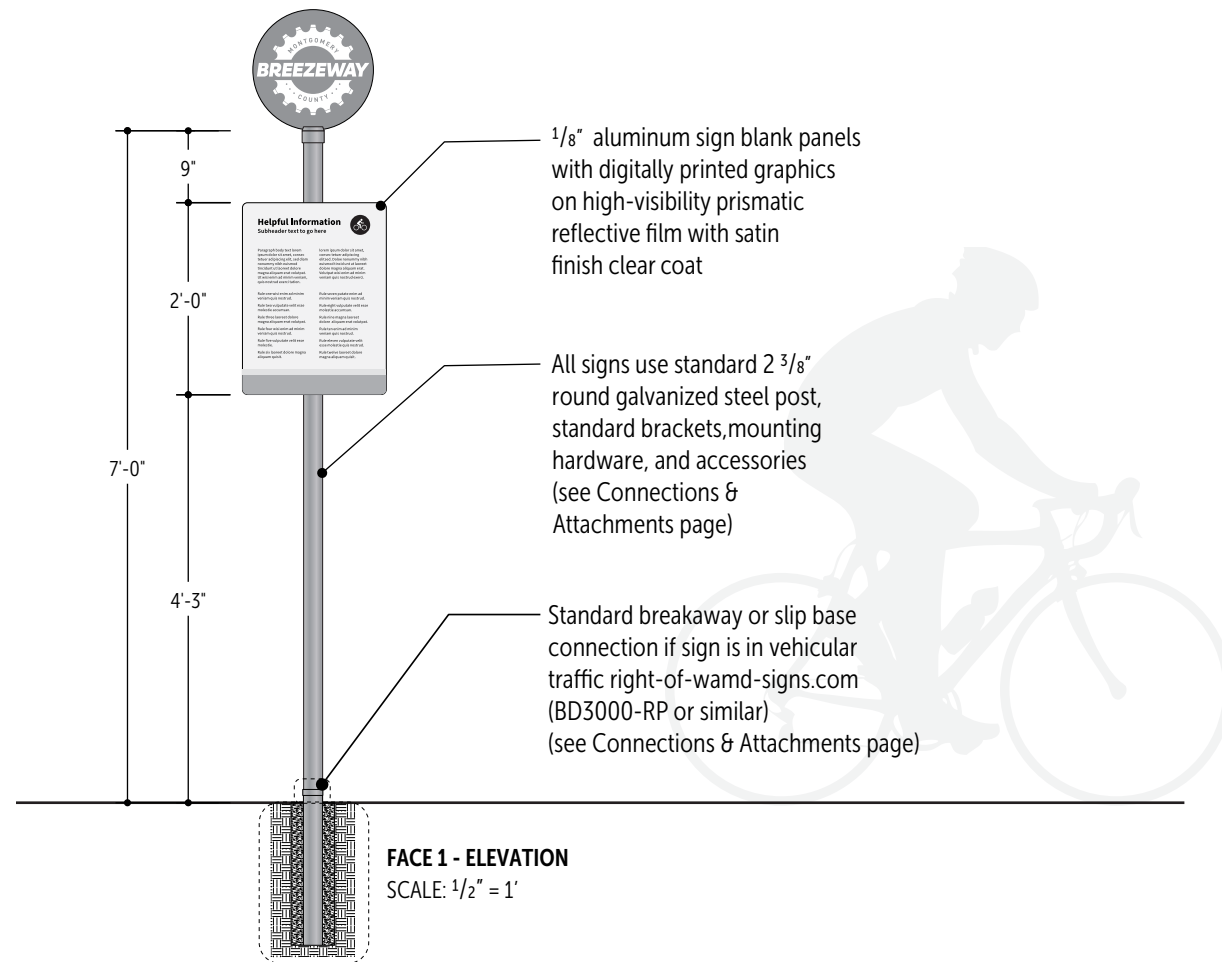

Text template provided by Owner

### GENERAL NOTES

Not For Construction – These drawings and notes are for the sole purpose of expressing visual design intent and are not intended for actual fabrication purposes. Sign Contractor accepts total responsibility for final material selection, fabrication and installation methods. Electronic files are not construction documents and cannot be relied upon as identical to construction documents because of changes or errors induced by translation, transmission, or alterations while under the control of others. Use of information contained in the electronic files is at the user's sole risk and without liability to Design Professional and its consultants. Refer to provided performance specifications for details on designer expectations of Fabricator and fabrication process. Copyright © Guide Studio, Inc. All rights reserved.

1. Sign contractor shall be responsible for design and engineering of supports, anchors and miscellaneous steel or metal required for installation.
2. The sign contractor's structural engineer shall be licensed in the state of the project and certify all connections and support details.
3. Isolate dissimilar materials as required.
4. Field dimensions shall be taken by the sign contractor prior to preparation of shop drawings and fabrication where possible. It is the responsibility of the sign contractor to site verify all sign locations for accuracy, fit, and potential obstacles. Sign contractor shall notify appropriate person(s) of any issues, discrepancies and potential obstacles per the attached Performance Specifications, contract, or specified communication process.
5. It is the responsibility of the sign contractor to contact appropriate services to verify locations of underground utilities.
6. Sign contractor must obtain all permits and field inspection approvals necessary to complete work per city requirements. All sign locations need to be located and staked by sign contractor and approved by the Bikeways Coordinator at the Montgomery County Department of Transportation prior to installation.
7. Sign contractor shall follow any additional requirements presented in the Performance Specifications.

# Attachments & Connections



**2 3/8" ROUND SIGN POST BREAKWAY**

SCALE: NTS

([www.safetysign.com/products/11568/round-sign-post-breakaway-coupler](http://www.safetysign.com/products/11568/round-sign-post-breakaway-coupler))  
Item #Y3555



**2 3/8" ROUND POST SURFACE MOUNT BREAKWAY**

SCALE: NTS

([www.safetysign.com/products/11168/snapn-safe-surface-mount-breakaway-anchor-for-round-post](http://www.safetysign.com/products/11168/snapn-safe-surface-mount-breakaway-anchor-for-round-post))  
Item #Y3543-238RSMB

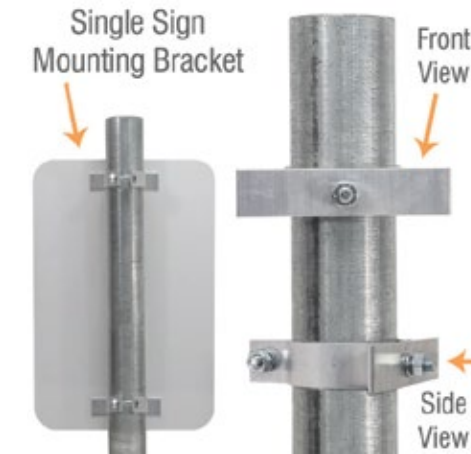

**2 3/8" ROUND SIGN POST BRACKET**

SCALE: NTS

([www.safetysign.com/products/8698/round-post-bracket](http://www.safetysign.com/products/8698/round-post-bracket))  
Item #Y3457

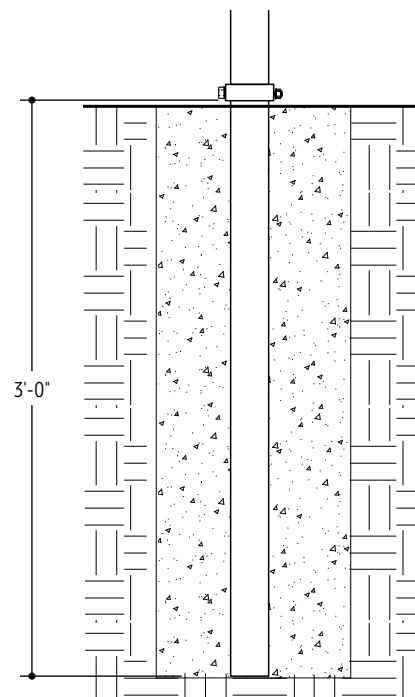

**CONCRETE FOOTER**

SCALE: 1 1/2" = 1'

Concrete footer depth per City Code  
(size per sign contractor)



**2 3/8" ROUND POST 5 1/2" STREET NAME SIGN BRACKET**

SCALE: NTS

([safetysign.com/products/8697/2 3/8" -round-post-street-name-sign-bracket](http://safetysign.com/products/8697/2-3/8-inch-round-post-street-name-sign-bracket))  
Item #Y3449



**SIGN PANEL POLE MOUNTING**

Scale: NTS

Snap-Lok worm clamp sign mounting kit for large poles, SKU:HRD-1038-1

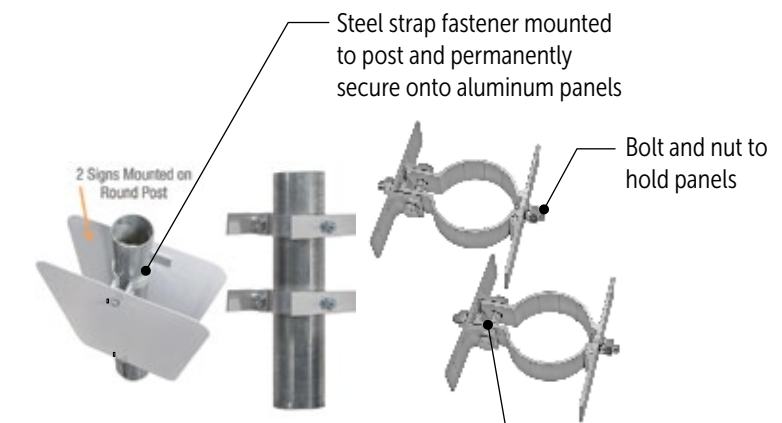

**SIGN PANEL POST MOUNTING**

Scale: NTS

**GENERAL NOTES**

Not For Construction – These drawings and notes are for the sole purpose of expressing visual design intent and are not intended for actual fabrication purposes. Sign Contractor accepts total responsibility for final material selection, fabrication and installation methods. Electronic files are not construction documents and cannot be relied upon as identical to construction documents because of changes or errors induced by translation, transmission, or alterations while under the control of others. Use of information contained in the electronic files is at the user's sole risk and without liability to Design Professional and its consultants. Refer to provided performance specifications for details on designer expectations of Fabricator and fabrication process. Copyright © Guide Studio, Inc. All rights reserved.

1. Sign contractor shall be responsible for design and engineering of supports, anchors and miscellaneous steel or metal required for installation.
2. The sign contractor's structural engineer shall be licensed in the state of the project and certify all connections and support details.
3. Isolate dissimilar materials as required.
4. Field dimensions shall be taken by the sign contractor prior to preparation of shop drawings and fabrication where possible. It is the responsibility of the sign contractor to site verify all sign locations for accuracy, fit, and potential obstacles. Sign contractor shall notify appropriate person(s) of any issues, discrepancies and potential obstacles per the attached Performance Specifications, contract, or specified communication process.
5. It is the responsibility of the sign contractor to contact appropriate services to verify locations of underground utilities.
6. Sign contractor must obtain all permits and field inspection approvals necessary to complete work per city requirements. All sign locations need to be located and staked by sign contractor and approved by the Bikeways Coordinator at the Montgomery County Department of Transportation prior to installation.
7. Sign contractor shall follow any additional requirements presented in the Performance Specifications.

APPENDIX

# Wayfinding & Signage Best Practices