

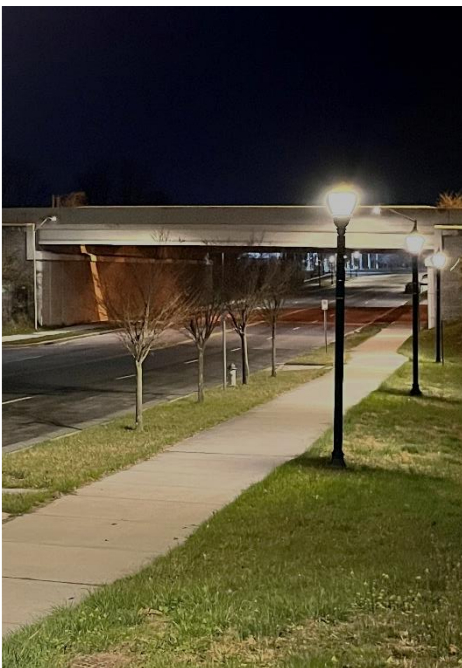

# Streetlighting Design Guidelines, Installation Procedures, and Specifications



# **Montgomery County**

## **Streetlighting Design Guidelines, Installation Procedures, and Specifications**

**June 2023**

# Contents

- Glossary ..... 1
- Streetlighting Overview ..... 3
  - How To Use This Guide ..... 3
  - Streetlighting Fundamentals ..... 4
  - Light and Visibility Principles ..... 4
  - Light Distribution ..... 5
- Streetlighting Considerations..... 6
  - Streetlighting Warrant Criteria ..... 6
  - Environmentally and Culturally Sensitive Areas ..... 8
  - Equity Considerations.....10
  - Light Level Target Criteria .....10
- Photometric Evaluation .....15
  - Light Source Selection .....15
  - Pedestrian-Scale Lighting .....15
  - Roadway-Scale Lighting .....17
  - Extraneous and Decorative Light Sources.....18
  - Photometric Layout.....18
  - Light Loss Factor .....19
- Streetlighting Design Plans .....20
  - Streetlighting Infrastructure.....20
  - Design Revisions.....20
  - Maintenance Considerations .....21
  - Other Design Considerations.....21
- Development Procedures .....23
- Emerging Technologies.....27
- Appendix A – Typical Applications.....28
- Appendix B – Utility Company Service Areas.....29

## Glossary

**Active Zone** – The portion of a public right of way that contains all active transportation such as pedestrians and bicyclists. Zone includes sidewalks or sidepaths, separated bike lanes, frontage zones, and a variety of buffers as defined in the [CSDG](#).

**ADA** – Americans with Disabilities Act.

**Backlight** – The backward component of the BUG rating system. The percent lamp lumens or the luminaire lumens distributed behind a luminaire between zero degrees vertical and 90 degrees vertical.

**BUG Rating** – A luminaire classification system developed to assess light trespass, glare, and skyglow. This system replaced the “cutoff” classification system, which focused on uplight. It provides the maximum lumens within defined angles for the primary areas known as backlight (B), uplight (U), and glare (G). FHWA recommends that veiling luminance be used rather than the glare component of the luminaire classification system when determining glare.

Clear Zone

**Correlated Color Temperature (CCT)** – A measure of the visual warmth or coolness of light expressed in kelvins (K). The lower the value, the more “warm” or yellow in color light appears. The higher the value, the more “cool” or blue in color the light appears.

**DarkSky** – Previously known as the International Dark-Sky Association, it is a non-profit organization focusing on combating light pollution worldwide. They provide a third-party, objective certification process for light fixtures that minimize glare, light trespass, and pollution. The certification is known as “DarkSky Friendly.”

**FHWA** – Federal Highway Administration.

**Glare** – The sensation produced by luminance within the visual field that is sufficiently greater than the luminance to which the eyes are adapted, causing annoyance, discomfort, or loss in visual performance and visibility.

**Horizontal Illuminance** – The amount of light falling on a horizontal plane. Increased values at night improve the accuracy and speed at which information can be ascertained by the user from the roadway environment.

**IES** – Illuminating Engineering Society.

**Intensity** – The measure of the concentration of light in a particular direction, which is expressed in candelas (cd).

**Illuminance** – The measure of the density of light on a surface divided by the area of the surface, which provides an average illuminance over that area. Illuminance is expressed in lux (lx) where 1 lx = 1 lumen per square meter, or footcandles (fc) where 1 fc = 1 lumen per square foot. See definitions of vertical, horizontal, and semi-cylindrical illuminance.

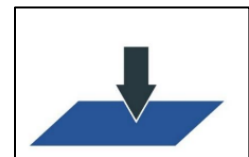

Figure 1. Horizontal Plane.  
(Source: FHWA)

**Lumens** – The unit measure of luminous flux, which is the amount of light emitted by a source in all directions.

**Luminance** – the measure of the concentration of light reflected toward the observe per unit area of surface. Luminance is expressed in candelas per square meter ( $\text{cd}/\text{m}^2$ ).

**Light Trespass** – The effect of light that strays from the intended purpose, or the encroaching of light causing annoyance, loss of privacy, or another nuisance.

**MCC** – [Montgomery County Code](#).

**MDOT SHA** – Maryland Department of Transportation State Highway Administration.

**Mounting Height** – The vertical distance between the street zone or active zone surface and the center of the apparent light source of the luminaire.

**Pedestrian-Scale Lighting** – Streetlighting providing luminaires with a mounting height less than 25 feet.

**Photometrics** – The measurement of quantities associated with light both visual and physical; also known as photometry.

**Roadway-Scale Lighting** – Streetlighting providing luminaires with a mounting height greater than or equal to 25 feet.

**Semi-Cylindrical Illuminance** – The amount of light falling on a vertical, semi-cylindrical plane. This metric provides a wider angle of measure that may more accurately represent the ability of a driver to see a pedestrian in some scenarios because it helps account for the three-dimensional nature of a pedestrian. It may also be an effective measure when considering pedestrian-to-pedestrian interactions, such as facial recognition.

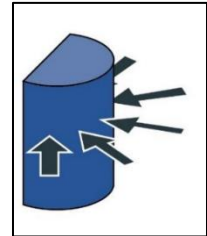

Figure 2. Semi-Cylindrical Plane. (Source: FHWA)

Street Buffer Zone

**Uniformity Ratio** – As used in this guideline, uniformity refers to the ratio of average horizontal illuminance to minimum horizontal illuminance within a given calculation area. Uniformity reduces the need for the eye to adapt to varying light conditions.

**Uplight** – The upward component of the BUG rating system. It is the percent lamp lumens or the luminaire lumens distributed above a luminaire between 90 and 180 degrees vertical.

**Veiling Luminance** – The metric used to evaluate disability glare as experienced by a driver. The term originates from the “veil” of luminance that is superimposed on the retina by stray light within the eye.

**Vertical Illuminance** – The amount of light falling on a vertical plane. Typically recorded at the eye level of observers oriented to their path of travel. This metric helps road users see objects and influences the amount of glare experienced by those users.

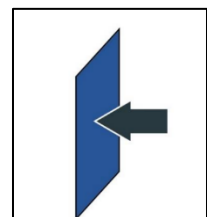

Figure 3. Vertical Plane. (Source: FHWA)

## Streetlighting Overview

Streetlights are primarily used for illuminating sidewalks, bikeways, and roadways to provide an enhanced visual environment for road users during times of darkness. The street network is a significant public asset, serving a multitude of important roles in the community. At the same time, streets are not always used to their full potential as public places of shared use. This document aligns the Streetlighting Design Guidance, Procedures, and Standards and Specifications for Materials and Construction with the County's [Complete Streets Design Guide \(CSDG\)](#), Vision Zero framework, and industry best practices for streetlighting. Similar to the County's CSDG, this guideline offers design considerations and recommendations to make our streets safer, more sustainable, and more vibrant. Streetlighting enhances transportation infrastructure by improving safety and providing inviting spaces, which also promotes economic exchange, recreation, and social engagement.

### How To Use This Guide

Montgomery County Department of Transportation (MCDOT) and Montgomery Planning, with funding from the Metropolitan Washington Council of Governments (MWCOG) Transportation Land Use Connections (TLC) program, developed this document to provide policy and design guidance to government agencies, consultants, private developers, and community groups on the planning, evaluation, design, and construction of streetlighting. This document should be used in the following situations:

- When designing future streets or reconstructed streets in an area experiencing land development.
- When implementing a capital improvement project, such as construction or reconstruction of a street, intersection, bridge, bikeway, walkway, or transit station.
- When conducting major work within public rights-of-way, which may create opportunities for reconsidering streetlighting of the roadway and active zones.
- When implementing traffic safety countermeasures that have identified the need for streetlighting at a given location.

In each of these circumstances, existing and proposed streetlighting conditions should be evaluated to determine if the desirable photometric criteria are or will be met. Photometric criteria are provided in Tables 1, 2, and 3 of this guideline. Recognizing that streetlighting design is complex and must respond to varied local conditions and site constraints, this document should be used in conjunction with engineering judgement to make site-specific decisions. Photometric criteria are desirable targets, and do not represent set standards that shall be maintained at all times. Lighting may not be appropriate in certain contexts where the costs and/or impacts outweigh the benefits. If lighting impacts are acceptable, photometrics may be designed to lower target values for a given context to minimize or mitigate potential impacts.

Montgomery County has an extensive street and trail network and as such, many of the recommendations in this document are meant to be implemented incrementally over time. The intent is that anyone involved in a project within public rights-of-way will actively seek out opportunities to design and retrofit streets and trails to meet target light levels with the

appropriate equipment and materials. Safety shall be held paramount while also considering environmental impacts, equity, maintenance, and sustainability.

This document establishes policy for the design of County-owned public rights-of-way, public spaces, or privately-owned streets located in the County. For State-owned roads, this guide is intended to present the County's vision for the roadway, to serve as a starting point for collaboration between the County and Maryland Department of Transportation State Highway Administration (MDOT SHA). State-owned rights-of-way are subject to the lighting criteria defined in MDOT SHA's Lighting Design Guide and the Standard Specifications for Construction and Materials.

The policy is intended to be a living document, to be supplemented and updated over time to adapt to the needs of the County, as well as to utilize emerging technologies and best practices.

## **Streetlighting Fundamentals**

Streetlighting is primarily used for lighting sidewalks, bikeways, and roadways to provide an enhanced visual environment for road users during times of darkness. Streetlighting, when used properly, reduces motor vehicle collisions, and provides a safer environment for all road users. Streetlighting can also be used to provide comfort for road users by providing a clearer knowledge of what lies ahead and a sense of personal security. Other non-road user considerations may include aesthetic and economic benefit of streetlighting that can be used to draw attention and visibility to commercial areas or other features.

Streetlighting substantially decreases nighttime collision rates, most importantly the occurrence of fatalities. While streetlighting has many benefits, the primary necessity for streetlighting along Montgomery County roadways is to enhance public safety and reduce traffic fatalities and serious injuries resulting from motor vehicle crashes.

To understand streetlighting, we must understand the human factors that are associated with lighting. These include both physical and psychological factors such as the condition of the driver's eyes, constantly changing eye adaptation, road user fatigue, and sensitivity to light. Visual cues comprise approximately 90% of a driver's information, which is used to control the vehicle, estimate gaps, detect hazards, and estimate speed.

Streetlighting is a critical component of traffic safety, but its installation and placement must also minimize adverse impacts to the natural environment. Lighting has been found to influence wildlife behavior and habits, as well as plant life responses. Electric lighting increases sky glow above the background levels through a combination of direct and reflected light. Any light emitted above the horizontal contributes directly to sky glow. To minimize sky glow, Montgomery County uses streetlight luminaires that are DarkSky Friendly. Light trespass must also be evaluated to ensure that obtrusive light from streetlighting does not negatively affect adjacent private properties.

## **Light and Visibility Principles**

For an overview of visible light and the principles of human vision, please refer to the Illuminating Engineering Society's (IES) [Recommended Practice: Lighting Roadway and Parking Facilities \(RP-8-21\)](#) or the [FHWA Lighting Handbook 2023](#).

Visibility and the factors influencing visual perception at night are complex and involve eyes undergoing constant adaptation to differing luminance levels. Within the public right-of-way, a road users' visual scene does not consist solely of a roadway surface and a potential hazard but may include opposing vehicle headlights and off-street light sources in addition to streetlighting. Contrast, visual acuity, and glare are important factors affecting visibility for road users.

Contrast for streetlighting refers to the difference between the luminance of an object and the luminance of the background. Human's contrast sensitivity is the ability of the eye to discern objects and backgrounds. Visual acuity is a measure of one's ability to identify details under a given set of lighting conditions. Glare is the presence of non-uniformities in the visual field, mostly resulting from bright sources that affect the adaptation of the eye. There are two categories of glare – disability and discomfort. Disability glare can drastically decrease visibility. Discomfort glare does not impact visibility but can result in physical pain and annoyance. Both are quantifiable, though disability glare is the only one with maximum recommended levels, which are defined in this guide.

## Light Distribution

IES defines a classification system for describing the lateral and longitudinal pattern of light that is produced by a luminaire. Distribution types range from Type I (very linear) to Type V (circular). These distribution types are illustrated below.

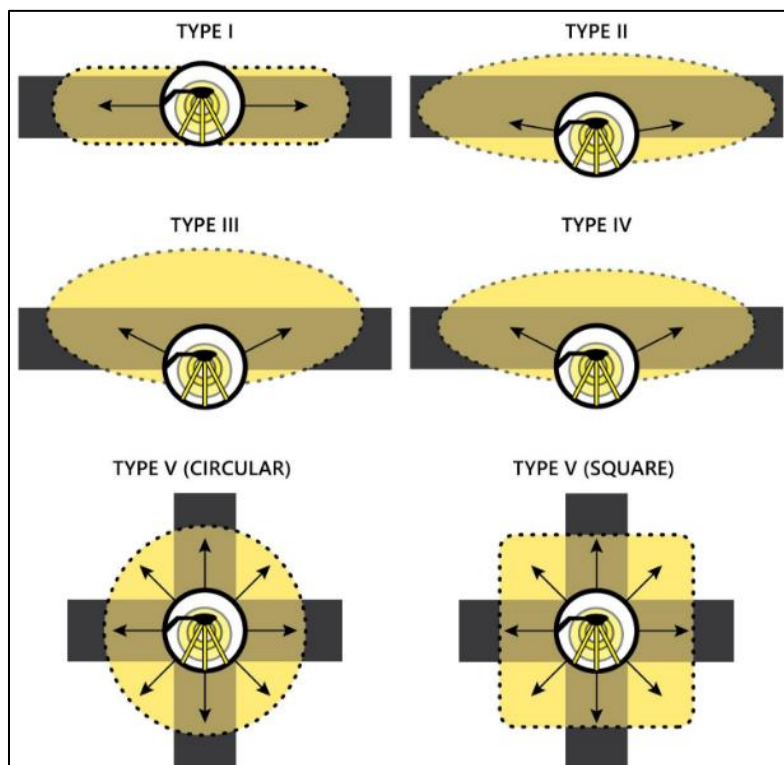

Figure 4. Lighting Distribution Types. (Source: FHWA)



## Streetlighting Considerations

The addition of streetlighting within public rights of way must be justified using various criteria to determine if a facility is eligible for streetlighting installations. Streetlights will not be approved if existing lighting conditions meet desirable light levels. If desirable light levels are not met, streetlighting will be considered under one or more of the following conditions:

- If streetlighting is required or recommended based on street typology as defined in the Complete Streets Design Guide (CSDG).
- If a residential area (Neighborhood Collector, Neighborhood Street, Neighborhood Yield Street, Country Road, Rustic Road, or Residential Shared Street) has a petition for streetlighting along a road segment that is supported by at least two-thirds (2/3) majority of affected residents (those residing in properties directly abutting the area to be lit). A petition is not required for business or industrial areas.
- Undeveloped segments of roadway may include streetlighting to address safety considerations.
- Intersection lighting and streetlighting along non-residential street types (Downtown Boulevard, Downtown Street, Town Center Boulevard, Town Center Street, Boulevard, Industrial Street, Country Connectors, Major Highways, or Commercial Shared Streets) may be installed without concurrence from abutting property owners.
- Streetlighting shall conform with the specifications of this document. MCDOT will not maintain streetlighting that uses non-standard poles, luminaires, or operating equipment without prior authorization.
- If streetlighting is recommended as a traffic safety countermeasure in a safety assessment prepared by MCDOT or Montgomery Planning.

To minimize additional light pollution, energy usage, and environmental impacts, facilities that are already lit that do not meet current photometric criteria outlined in this guidance document should be prioritized to be upgraded over providing lighting where it is not currently present, except in locations where a safety issue exists, or a new transportation facility has been constructed.

### Streetlighting Warrant Criteria

Street type should be the primary factor for determining if streetlighting is to be pursued for a given project or facility, as identified in Table 1 on the next page. Building on the CSDG considerations, a literature review of industry best practices and research informs the criteria established in Table 1 for Streetlighting Warrant Criteria for both active zones and streets zones, with street zones broken into intersections and segments (continuous roadway lighting). Table 1 provides Warrant Criteria based on the CSDG Street Types.

**Table 1. Streetlighting Warrant Criteria**

CDSG Street Type	Active Zone	Street Zone	
		Intersection	Segment
Downtown Boulevard	Required	Required	Required
Downtown Street	Required	Required	Required
Boulevards	Required	Required	Recommended
Town Center Boulevard	Required	Required	Required
Town Center Streets	Required	Required	Required
Area Connector	Required	Required	Recommended
Neighborhood Connector	Required	Required	Recommended
Neighborhood Streets	Recommended	Required	Optional
Neighborhood Yield Streets	Recommended	Required	Optional
Industrial Street	Optional	Required	Recommended
Country Connector	Optional	Required	Recommended
Country Roads	Optional	Optional	Optional
Major Highway	Optional	Required	Required
Alley	Optional	Optional	Optional
Rustic Road	Optional	Optional	Optional
Shared Street	Required	Required	Required
Bikeways	Active Zone	Street Zone	
		Intersection	Segment
Off-Street / Trail	Required	Required	N/A
Sidepath / Shared Use Path / Separated or Protected Bike Lanes	Required	Required	N/A
On-Street Bikeway*	N/A	Required	See Street Type
Transit Corridors	Active Zone	Street Zone	
		Intersection	Segment
Dedicated or Shared Transitway	Required	Required	Required

\*On-street bikeways include buffered bike lanes, advisory bike lanes, conventional bike lanes, bikeable shoulders, shared streets, neighborhood greenways, and priority shared lane markings

Where streetlighting is optional, a context-sensitive approach should be used in evaluating the appropriateness of an installation. This may include a lower correlated color temperature (CCT), house side shielding, or reduced light level targets. A Historic District or adjacent property may require use of non-standard structures or fixtures to keep in character with the historic setting. Context-sensitive considerations may result in the decision to not provide streetlighting where it's determined that the benefits do not outweigh the impacts and costs. Higher CCT or light level targets may be desirable in locations with perceived personal safety concerns or increased rates of crime.

Separately, the inclusion of bikeways or transitways along a street should consider streetlighting independently of the CSDG Street Types. Active and Street Zones along with their basic components are illustrated in Figure 5 below.

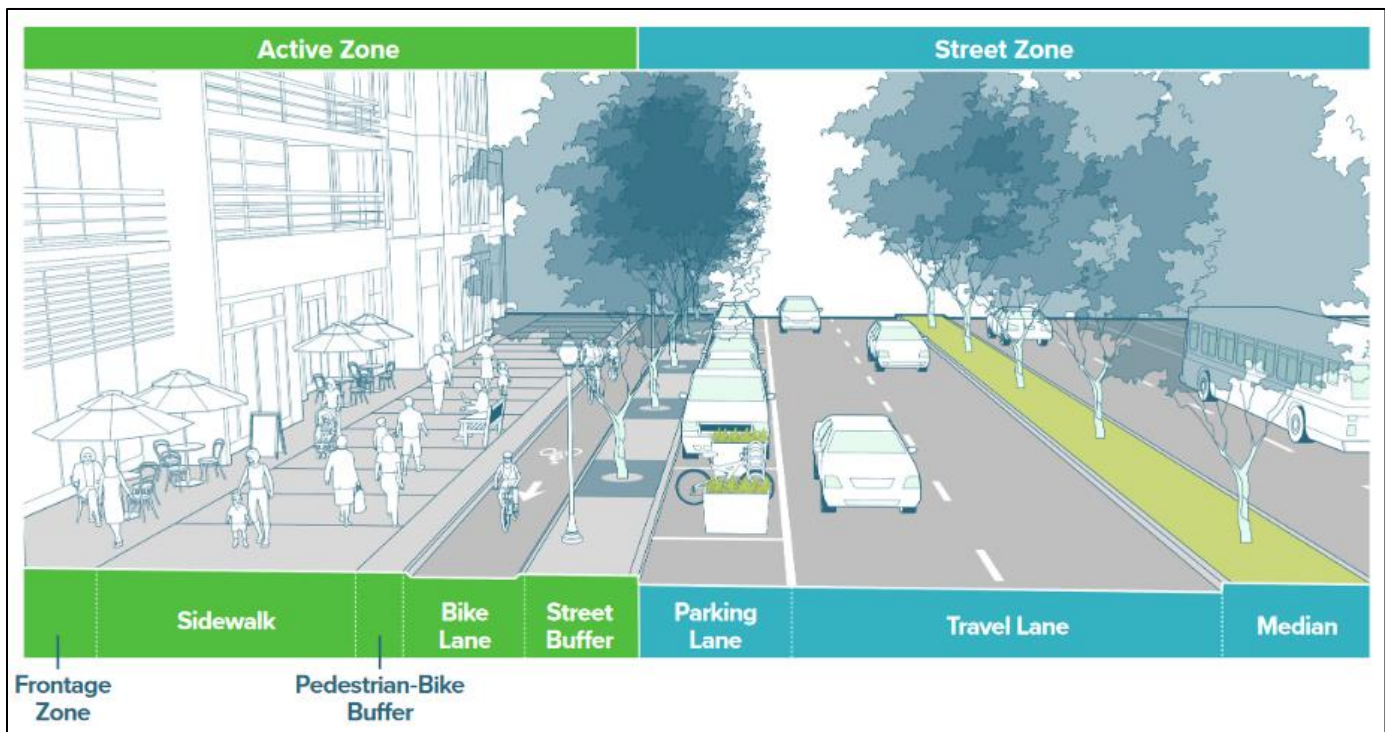

Figure 5. Street and Active Zones Defined. (Source: Montgomery County CSDG)

## Environmentally and Culturally Sensitive Areas

As noted in [Thrive Montgomery 2050](#), the update to the County's General Plan, transportation systems that make alternatives to driving practical and attractive are an essential component of a comprehensive strategy to fight climate change. A stronger focus on walking, biking, and transit infrastructure is crucial. Active Zones must be appropriately lit to provide safety and comfort while balancing ecological impacts to surrounding wildlife, natural resources, and areas of cultural and historical significance.

Streetlighting proposals should be cross referenced with Environmentally and Culturally Sensitive Areas (ECSA) as defined by Montgomery Parks and Planning. Light level criteria should first be defined by the Street Type. Where proposal would introduce artificial light into ECSAs, Street Type light level criteria may have an adverse impact that outweighs the benefit of the

streetlighting. Flexibility in light level target criteria and streetlighting equipment may be appropriate to ensure ecological impacts are balanced with the goals and objectives of the project. Design flexibilities may include mitigating light trespass with shielding, reducing light output or warmer color temperatures in combination with reduced light level targets, or “no-build” scenarios where streetlighting is omitted in critical areas or for an entire project. Lighting controls will improve flexibility as new technologies become more reliable and cost efficient. Refer to the Emerging Technologies section for further discussion of lighting controls.

ECSAs as defined by Montgomery Parks and Planning are listed below in Table 2.

**Table 2. Environmentally and Culturally Sensitive Areas**

Areas	Definition
Agricultural Areas	Agricultural Reserve
Conservation Oriented Parks	Best Natural Areas, Biodiversity Areas, Conservation Parks, Stream Valley Parks, Regional Parks
DNR Focal Areas	Targeted Ecological Areas, Rural Legacy Areas
Forests	Biological community dominated by trees and other woody plants covering a land area of 10,000 square feet or greater. Areas that have at least 100 trees per acre with at least 50% of those trees having 2-inch or greater diameter at a height 4.5 feet above ground, including areas that have been cut but not cleared.
Historic Properties / Historic Districts	Individual properties and historic districts that are: Listed in the County’s Master Plan for Historic Preservation; Identified in the County’s Locational Atlas and Index of Historic Sites; Or Listed in or determined eligible for listing in the National Register of Historic Places.
Meadows / Grasslands	Areas dominated by herbaceous vegetation (>80% cover).
State Designated Protected Lands	DNR Owned Lands and Conservation Easements, Rural Legacy Properties, MD Environmental Trust Easements, Forest Conservation Act Easements, MD Agricultural Land Preservation Foundation Easements, Local Protected Lands, Coast and Estuarine Land Conservation Program, Private Conservation Lands, Protected Federal Lands, and Transfer Development Rights and Purchase Development Rights
Streams	Body of water within a channel that flows at last some of the time.
Wetlands	Area that is inundated or saturated by surface water or groundwater at a frequency and duration sufficient to support, and that under normal circumstances does support, a prevalence of vegetation typically adapted for life in saturated soil conditions, commonly known as hydrophytic vegetation.

Streetlighting proposals within any of the ECSAs listed above, the design team and MCDOT should meet with Montgomery Parks and Planning staff to determine the appropriate light level criteria and approaches to mitigate ecological impacts from artificial light sources.

## Equity Considerations

Streetlighting proposals should be implemented following the principles of the County's [Vision Zero Equity Framework](#). While safety projects recommended or requested by communities should be given priority, funding, County resources, and types of projects should be prioritized using data-driven approaches. Prioritization of streetlighting improvements and allocation of resources should focus on the transportation modes and communities experiencing the highest rates of fatal and serious injury crashes while also considering equity emphasis areas, school walksheds, and areas with high rates of senior populations that may be at higher risk for traffic-related death or injury.

Traffic safety outcomes are a core component of transportation equity, but designers must also consider the impacts of artificial lighting on the surrounding community when performing equity evaluations. The built environment must provide equitable safety outcomes and accessibility for communities, as well as address inequities resulting from the negative impacts of streetlighting.

## Light Level Target Criteria

The Active Zone is comprised of the elements of the public right of way located off-street – the Street Buffer Zone, Clear Zone, and Frontage Zone. The Street Buffer Zone is adjacent to the curb line or edge of pavement and is the preferred location for the placement of streetlighting, but must compete for space with trees, vegetation, street furniture, signs, utilities, and green infrastructure. The Clear Zone is the area behind the Street Buffer Zone that is specifically reserved for walking and rolling. The Clear Zone is labeled as the sidewalk/sidepath in Figure 6 below. It should provide accessible pedestrian space meeting the appropriate vertical and horizontal clearance requirements. The Frontage Zone is the space between the Clear Zone at the right-of-way boundary or building frontage. It is desirable for light levels to meet target values for the entire Active Zone, but various constraints may limit the calculation area to the Clear Zone. Table 3 provides the target light level criteria for Active Zones.

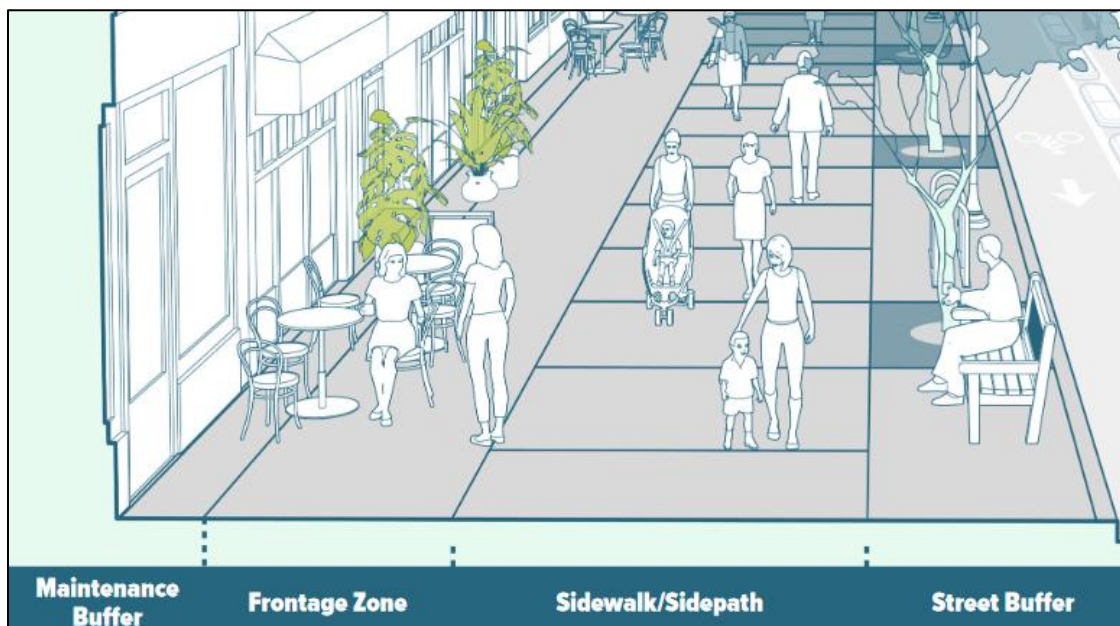

Figure 6. Active Zone. (Source: Montgomery County CSDG)

**Table 3. Target Lighting Values for Active Zones**

CSDG Street Type	Active Zones Adjacent to Roadways				
	Minimum Horizontal Illuminance (fc), $E_{H,min}$	Maintained Average Horizontal Illuminance (fc), $E_{H,avg}$	Maintained Average Vertical Illuminance (fc), $E_{V,min}$	Uniformity Ratio ( $E_{H,avg} / E_{H,min}$ )	Maintained Average Surface Luminance ( $cd/m^2$ ), $L_{avg}$
Downtown Boulevard	0.2	0.9	1.0 – 1.2	3.0	2.0 – 2.5
Downtown Street					
Boulevards	0.2	0.5	0.2 – 0.4	4.0	1.0 – 1.5
Town Center Boulevard	0.2	0.9	1.0 – 1.2	3.0	2.0 – 2.5
Town Center Streets					
Area Connector	0.2	0.5	0.2 – 0.4	4.0	1.0 – 1.5
Neighborhood Connector					
Neighborhood Streets					
Neighborhood Yield Streets					
Industrial Street	0.2	0.3	0.2 – 0.4	6.0	1.0 – 1.5
Country Connector	0.1	0.2	0.2 – 0.4	10.0	0.4 – 1.0
Country Roads					0.3 – 0.8
Major Highway	0.2	0.3	0.2 – 0.4	6.0	0.8 – 1.3
Alley	0.2	0.5	0.2 – 0.4	4.0	1.0 – 1.5
Rustic Road	0.1	0.2	0.2 – 0.4	10.0	0.3 – 0.8
Shared Street	0.2	0.9	1.0 – 1.2	3.0	2.0 – 2.5
<b>Specialty</b>	<b>Active Zones in Area with Increased Security Needs</b>				
Security	0.5	1.2	2.2 – 2.4	3.0	2.0 – 2.5
<b>Facility</b>	<b>Active Zones Not Adjacent to Roadways</b>				
Trail / Shared Use Path	0.1	0.4 – 2.0	0.5	4.0	1.0
Tunnel	-	5.4	5.4	3.0	2.0

1. The low end of the range is for Roadway-Scale light sources, while the high end of the range is for Pedestrian-Scale light sources.

The Street Zone is the area bound by the curbs or pavement that provides access and mobility for motor vehicles, transit, freight, and emergency vehicles. It can be further divided into the Curbside Zone, Travelway Zone and Median Zone. The Curbside Zone is the area adjacent to the Active Zone that may be used for on-street parking, active transportation corrals, loading zones for people or freight, on-street bikeways, or parklets. These uses may vary by segment and by time of day. The Travelway Zone is used for the movement of motor vehicles, transit, freight, and emergency vehicles, and in many locations, bicycles or micromobility vehicles. The Median Zone runs along the center of the Street Zone and can be used to bifurcate opposing directions of travel in addition to providing space for stormwater management, landscaping, transit access, auxiliary turn lanes, and other roadway elements. The Median Zone may also be used for placement of streetlighting. **Error! Reference source not found.** illustrates the Street Zones below.

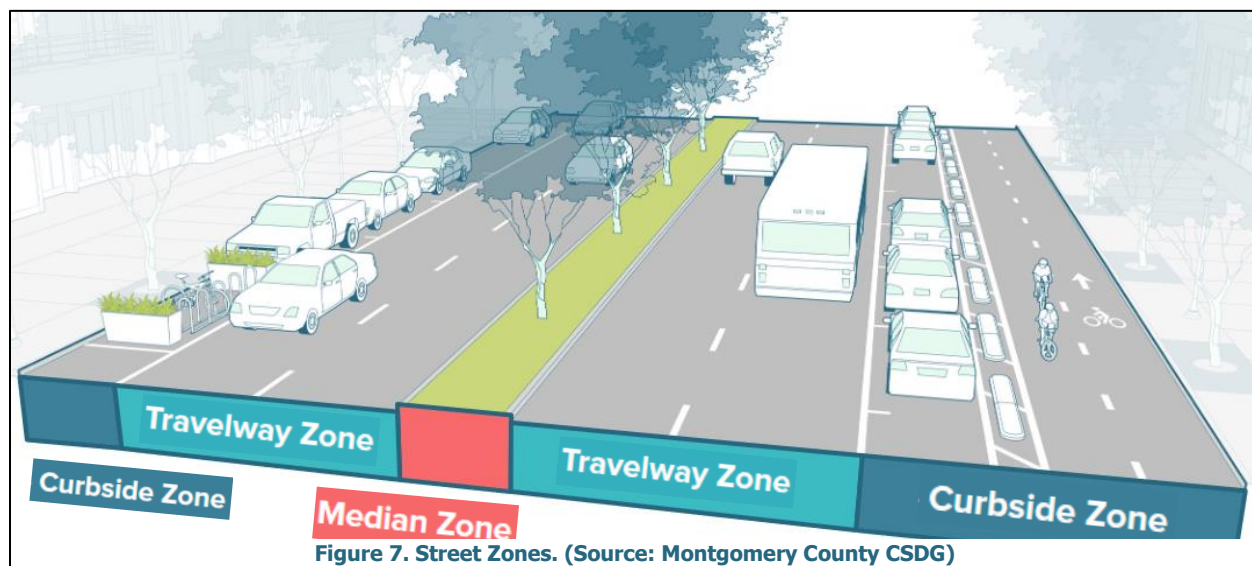

Table 4 provides the target minimum light level criteria for Street Zones where two streets intersect. Table 5 provides the target minimum light level criteria for Street Zones along segments (in between intersections). The intersection area should be bound by the outer limits of crosswalks for uncontrolled approaches or stop lines for controlled approaches. Median Zones are desirable to include in photometric calculation areas, but where pedestrian refuge is not provided, illumination of the Median Zone is optional. On-street bike facilities located within the curbside zone shall be included in Street Zone calculations.

The light level criteria provided in this guide are derived from literature review of industry best practices and research related to streetlighting, as well as recommended lighting criteria provided by IES and FHWA. Lighting criteria is based on a variety of street parameters including speed, traffic volumes, median presence, intersection or interchange density, ambient lighting conditions, pavement marking quality, VRU activity levels, on-street parking, and security needs. The approach outlined in the FHWA Lighting Handbook 2023 has been adapted for use with the Montgomery County CSDG Street Types using design parameters defined in the Lighting Handbook that most closely align with the target design parameters for each CSDG Street Type.

**Table 4. Target Lighting Values for Street Zones – Intersections**

Highest CSDG Street Type for Intersections	Minimum Horizontal Illuminance (fc), $E_{H,min}$	Maintained Average Horizontal Illuminance (fc), $E_{H,avg}$	Uniformity Ratio ( $E_{H,avg} / E_{H,min}$ )
Downtown Boulevard	0.1 – 0.5	1.3 – 2.0	3.0
Downtown Street			
Boulevards			
Town Center Boulevard			
Town Center Streets			
Area Connector			
Neighborhood Connector	0.2 – 0.5	1.3 – 1.5	4.0
Neighborhood Streets			
Neighborhood Yield Streets			
Industrial Street			
Country Connector			
Country Roads			
Major Highway	0.1 – 0.5	1.3 – 2.0	3.0
Alley	0.2 – 0.5	1.3 – 1.5	4.0
Rustic Road			
Shared Street	0.1 – 0.5	1.3 – 2.0	3.0



**Table 5. Target Lighting Values for Street Zones – Segments**

<b>CSDG Street Type</b>	<b>Maintained Average Horizontal Illuminance (fc), <math>E_{H,avg}</math></b>	<b>Uniformity Ratio (<math>E_{H,avg} / E_{H,min}</math>)</b>	<b>Maintained Average Surface Luminance (<math>cd/m^2</math>), <math>L_{avg}</math></b>	<b>Veiling Luminance (<math>L_{max}/L_{avg}</math>)</b>
Downtown Boulevard	0.7 – 1.0	3.0	0.6 – 1.5	0.3
Downtown Street				
Boulevards				
Town Center Boulevard				
Town Center Streets				
Area Connector	0.6 – 0.7	3.0	0.4 – 1.0	0.4
Neighborhood Connector				
Neighborhood Streets	0.2	6.0	0.3 – 0.8	0.4
Neighborhood Yield Streets				
Industrial Street	0.6 – 0.7	3.0	0.4 – 1.0	0.4
Country Connector				
Country Roads	0.2	6.0	0.3 – 0.8	0.4
Major Highway	0.6 – 0.8	3.0	0.8 – 1.3	0.3
Alley	0.2	6.0	0.3 – 0.8	0.4
Rustic Road				
Shared Street	0.7 – 1.0	3.0	0.6 – 1.5	0.3

# Photometric Evaluation

## Light Source Selection

Once streetlighting design and photometric considerations are defined and agreed upon, site-specific structures and fixtures must be selected from MCDOT’s standard specifications. Alternate poles, fixtures, luminaires, or controls may be proposed, but will require an executed memorandum of understanding (MOU) detailing responsibilities for ongoing maintenance and operation of non-standard streetlighting equipment. MCDOT does not operate or maintain non-standard streetlighting equipment. Emerging technologies may be tested and reviewed for adoption into standard specifications as opportunities are presented. Formal adoption of emerging technologies and new equipment are subject to available funding and resources.

Standard equipment for both pedestrian-scale and roadway-scale streetlighting is detailed in this section. Pedestrian-scale streetlighting refers to any luminaire and pole with a mounting height less than 25 feet above grade. A mounting height greater than or equal to 25 feet is referred to as roadway-scale streetlighting. Pedestrian-scale lighting may be used to illuminate the Street Zones or Active Zones. Lower mounted fixtures may increase glare along a street segment. When pedestrian-scale lighting is used, it may require greater offset from the Street Zone or increased luminance levels to ensure that glare will be within the acceptable range. Roadway-scale lighting is typically used for illuminating Street Zones but may also be used to light Active Zones. Higher mounted fixtures provide greater lighting coverage, allowing for less structures to be placed within a given area. However, higher mounting heights increase light spillover and due care should be taken to ensure that light trespass is properly accounted for and mitigated to limit adverse impacts to adjacent properties and the environment.

## Pedestrian-Scale Lighting

### Washington Globe

Application	<b>Active Zone:</b> All Street Types Off-Street Bikeways and Trails <b>Street Zone:</b> Neighborhood Connectors, Neighborhood Streets, and Neighborhood Yield Streets
Colors	Federal Green, Semi-Gloss Black
Posts	<b>General:</b> Decorative Residential Lamp Post Decorative Residential Lamp Post (Direct Burial) <b>Silver Spring:</b> Decorative Silver Spring Lamp Post
Footings	Direct burial (fiberglass) Concrete foundation (cast poles)



Figure 8. Washington Globe

### Bethesda Globe

Application	<b>Active Zone:</b> All Street Types Downtown Bethesda <b>Street Zone:</b> Neighborhood Connectors, Neighborhood Streets, and Neighborhood Yield Streets
Colors	Federal Green, Semi-Gloss Black
Posts	Decorative Bethesda Cast Streetlight Post
Footings	Direct burial (fiberglass) Concrete foundation (cast poles)

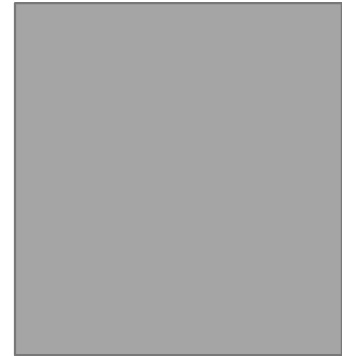

Figure 9. Bethesda Globe

### Colonial Post Top

Application	<b>Active Zone:</b> All Street Types Off-Street Bikeways and Trails <b>Street Zone:</b> Neighborhood Connectors, Neighborhood Streets, and Neighborhood Yield Streets
Colors	Gray, Federal Green, Semi-Gloss Black
Posts	Decorative Residential Lamp Post (Direct Burial)
Footings	Direct burial



Figure 10. Colonial Post Top

### Damascus Pendant – Pedestrian

Application	<b>Active Zones:</b> Downtown Boulevards, Downtown Streets, Town Center Boulevards, Town Center Streets, Boulevards, and Country Roads Damascus Town Center
Colors	National Park Service Brown, Hunter Green
Poles	Decorative Damascus Pedestrian Streetlight Pole Wall Mounting
Footings	Concrete Foundation



Figure 11. Damascus Pendant

### Contemporary Post Top

Application	<b>Active Zones:</b> Downtown Boulevards, Downtown Streets, Town Center Boulevards, Town Center Streets, and Boulevards Downtown Wheaton
Colors	Gray, Semi-Gloss Black
Posts	Wheaton Pedestal Lamp Post
Footings	Concrete foundation



Figure 12. Contemporary Post Top

### Silver Spring Shallow Tear Drop – Ped

Application	<b>Active Zones:</b> Downtown Silver Spring
Colors	Federal Green
Pole	Decorative Atlanta-Style Pedestrian Lamp Post
Footings	Concrete Foundation



Figure 13. Silver Spring Shallow Tear Drop (Ped)

## Roadway-Scale Lighting

### Cobrahead (Roadway Pendant)

Application	<b>Active Zones:</b> All Street Types <b>Street Zones:</b> All Street Types Alleyways Off-Street Bikeways and Trails
Colors	Gray
Poles	Fiberglass Roadway Streetlight Pole Spun Aluminum Roadway Streetlight Pole
Footings	Direct Burial (fiberglass) Concrete Foundation (aluminum)



Figure 14. Cobrahead

### Rectilinear (Area Light)

Application	<b>Active Zones:</b> All Street Types <b>Street Zones:</b> All Street Types
Colors	National Park Service Brown
Pole	Decorative Tall Post Decorative Square Steel Multi-Use Streetlight Pole Decorative Square Steel 40-Foot Streetlight Pole
Footings	Concrete Foundation



Figure 15. Rectilinear (Area Light)

### Damascus – Vehicular

Application	<b>Street Zones:</b> Downtown Boulevards, Downtown Streets, Town Center Boulevards, Town Center Streets, and Country Roads
Colors	National Park Service Brown, Hunter Green
Pole	Decorative Damascus Vehicular Streetlight Pole
Footings	Concrete Foundation



Figure 16. Damascus (Veh.)

### Silver Spring Tear Drop – Vehicular

Application	<b>Street Zones:</b> Downtown Silver Spring
Colors	Federal Green
Pole	Decorative Atlanta-Style Vehicular Streetlight Pole
Footings	Concrete Foundation



Figure 17. Silver Spring Tear Drop (Veh.)

### Wheaton Highlight

Application	<b>Street Zones:</b> Downtown Boulevards, Downtown Streets, Town Center Boulevards, Town Center Streets Downtown Wheaton
Colors	Semi-Gloss Black
Pole	Wheaton Vehicular Streetlight Pole
Footings	Concrete Foundation



Figure 18. Wheaton Highlight

## Extraneous and Decorative Light Sources

While extraneous light sources contribute to the ambient light conditions within a public right of way, they are not acceptable substitutes for light sources maintained and operated by MCDOT. Parking lot area lights, building sconces and lanterns, illuminated bollards, flood lights, string lights, and other artificial light sources installed by others in public spaces or on private property adjacent to the public right of way shall not be factored into photometric analysis. These light sources are not controlled by MCDOT, nor can their specifications be easily verified.

No artificial light sources are permitted within County public rights of way without approval from MCDOT.

## Photometric Layout

Photometric evaluations should be performed using computer software that follows the calculation methodologies detailed in IES RP-8-21, *Recommended Practice: Lighting Roadways and Parking Facilities*. While photometric evaluations are necessary for proposed permanent streetlighting conditions, they may also be used for determining existing lighting conditions. Where a major capital improvement project will require various phases of construction, realignment and reconfiguration of the Street Zone or Active Zone may require photometric evaluation of temporary conditions to ensure adequate light levels are maintained throughout construction for the safety of both road users and construction workers. Plans and specifications will require contractors to maintain existing streetlighting throughout construction. The design

team should coordinate with MCDOT once a preliminary maintenance of traffic sequence has been established to determine if the construction phases justify the need for temporary lighting design and photometric evaluation.

Light sources used in photometric analyses shall be those identified in the Streetlight Specifications. Mounting heights to use for photometric evaluation are detailed in the Streetlighting Specifications and Standard Drawings. While the preferred placement is within the Street Buffer Zone, streetlighting placement may vary based on site constraints and photometric needs. General placement of streetlight structures should follow the criteria below:

- Minimum 2' offset from curb face for closed sections.
- Minimum 6' offset from edge of roadway for open section.
- Minimum 2' offset from edge of bikeway.
- Desirable minimum 5' offset from driveways and utilities.
- Desirable minimum 15' offset from center of trees.

Streetlighting should be placed in a manner that is consistent, regular, and compatible with other street design elements. Uniform spacing and a consistent pattern for streetlighting and street trees is highly desirable to limit road user distraction and provide a cohesive sense of place along a corridor.

### **Light Loss Factor**

The light loss factor (LLF) applied to a fixture is a product of multiple factors related to equipment and maintenance. Lamp lumen depreciation (LLD) describes the gradual reduction in light output over the lifetime of a fixture. This information is typically provided by manufacturers. Luminaire dirt depreciation (LDD) describes the reduction in luminaire light output resulting from the accumulation of dirt on both the inside and outside of a luminaire reflector. MDOT SHA specifications define a LLF of 0.81 for LED roadway luminaires. Typical luminaires used by MCDOT are expected to have a LLF between 0.80 and 0.90. Where street trees are expected to interfere with light output along a Street Zone or Active Zone, FHWA recommends applying an additional 10% to 20% light loss to account for shading.

LLF should be discussed and agreed upon by the designer and MCDOT prior to performing photometric analysis. When streetlighting installations are located within MDOT SHA rights of way, a LLF of 0.81 shall be used.

## Streetlighting Design Plans

All streetlighting plans shall be reviewed and approved by MCDOT prior to construction. Streetlighting design must be verified by photometric analysis and approved by MCDOT. All materials shall be per MCDOT specifications. All streetlights shall be energized by the utility company and placed into operation prior to the County acceptance of the project.

### Streetlighting Infrastructure

#### Splice Boxes

Splice boxes shall be provided adjacent to all streetlight structures to serve as access, as well as providing a boundary for establishing MCDOT and utility company maintenance responsibilities. Splice boxes may be required to meet the specifications of the utility company. Cover shall be installed flush with the final grade, sidewalk, or pathway. The structures shall be designed for light truck loading per ASTM C857. If a splice box location requires installation within a vehicular travel way, MDOT SHA Standards MD 811.04 and MD 811.04-01 shall be used.

#### Conduits

All electrical cables for streetlighting shall be run in Schedule 40 or 80 rigid polyvinyl chloride (PVC) conduits installed with a minimum 24 inches of ground cover. Streetlighting conduit sizes should follow the requirements of the utility company. Streetlighting conduits installed beneath the roadway shall be 4-inch diameter. Conduits installed via directional boring may be constructed of high-density polyethylene (HDPE) in lieu of PVC.

#### Ground Rods

Ground rods are to be installed in all splice boxes adjacent to streetlighting poles. If a splice box is not provided, the ground rod should be installed adjacent to the streetlight pole. Connections between ground wire and ground rods should be made by exothermic weld.

#### Cable

Streetlight installations shall include wiring from the luminaire to the base of the support or to the adjacent handbox as applicable. Three (3) #10 AWG electrical cables are to be provided between the luminaire and the location where the utility will splice into branch circuits.

### Design Revisions

In circumstances where site conditions have evolved or previously unknown constraints or considerations require shifting of a streetlight greater than 10 feet from its location in the approved photometric analysis, the designer shall update the photometric plan and resubmit to MCDOT for approval. Design changes may not result in a lighting condition that is substandard to the agreed upon target criteria or create additional light trespass exceeding allowable thresholds. MCDOT may require justification where targets can no longer be met.

While this guide provides specifications for streetlighting luminaires and poles, environmental and land use contextual considerations may justify deviation from targets. Alternate correlated color temperatures (CCTs) may be considered for neighborhoods or environmentally sensitive areas where a reduction to 2700K may better align with the character of a community. This

may be applicable for streetlighting installations within Historic Districts, adjacent to historic properties, adjacent to or within Parks properties, or other context-sensitive areas.

Deviation from criteria may also be necessary due to site-specific constraints. Shielding of luminaires can be used to minimize adverse impacts to wildlife and light trespass along adjacent residential properties. Light level targets may be less than desirable where it is impractical to install streetlighting due to overhead and underground utility constraints. Leased lights may be installed on utility poles to provide streetlighting, but placement would be subject to the existing locations of utility poles along a segment.

## Maintenance Considerations

It is recommended that splice boxes be provided adjacent to all streetlight poles, and that access holes be provided at the base of all streetlight poles to accommodate maintenance efforts for replacing and troubleshooting issues in the field. Roadway-scale lighting that places luminaires over the roadway should minimize encroachment into the travelway for achieving light level targets. This will limit the need for temporary lane closures and allow for maintenance workers to be buffered from active travelways. All streetlighting structures shall be placed in compliance with the Maryland High Voltage Line Act, providing adequate aerial clearance from utilities to accommodate safe installation and maintenance of streetlighting.

Splice boxes placed within Active Zones, specifically the Clear Zone, present hazards to those walking and rolling should the splice box cover be damaged or when maintenance work is taking place. Splice boxes should be placed outside of the Clear Zone when practical.

Stakeholders often inquire about the implementation of non-standard equipment and controls as part of a streetlighting design. Timers, adaptive lighting sensors, and similar products cannot presently be maintained by MCDOT will continue to be evaluated and considered for formal adoption as funding and resources become available. See Emerging Technologies section for additional information.

Luminaires and photocells may require routine cleaning to ensure photocontrol operates as intended, and light remains close to the initial lumen output of the fixture. MCDOT maintains the physical infrastructure needed for streetlighting including splice boxes, conduits, foundations, and poles. Luminaires and wiring are maintained by the utility company.

## Other Design Considerations

Physical site constraints may dictate streetlighting placement, mounting heights, and circuitry layout. The following should be considered during streetlighting plan development:

**Power Source:** The availability of electrical power may impact a decision to provide streetlighting. As photovoltaics and energy storage systems improve and become more efficient, cheaper, and readily available, alternatives to hardwire electrical power should be considered. Presently, streetlighting requires a hardwire connection to a public utility. These connections may be metered or unmetered. Streetlighting circuits to be owned and maintained by MCDOT are typically unmetered. Streetlighting plans must identify proposed power sources – utility pole, transformer, junction box, or electrical manhole. The ultimate power service location and design will be provided by the utility company.



**Proximity to Aircraft Facilities:** Typically, an airport authority will have specific pole height limitations within a defined glide path surrounding an airfield. Aircraft facilities in close proximity to streetlighting installations should be identified early in the design process to determine the relevant criteria for that specific facility.

**Overhead Utilities:** Streetlighting designs and installations shall adhere to the Maryland High Voltage Line Act and National Electric Code (NEC). Transmission lines in close proximity to streetlighting installations should be identified early in the design process and radial clearances verified with utility companies.

**Roadside Safety:** Streetlighting pole placement should adhere to the AAHSTO *Roadside Design Guide*. Structures may require the use of transformer bases that meet MASH criteria depending on the operating speed of a roadway and offset from the traveled way.

## Development Procedures

All submissions should be made electronically via email. Photometric analysis and streetlighting plans should be sent to [streetlights@montgomerycountymd.gov](mailto:streetlights@montgomerycountymd.gov). For site development projects, procedures are outlined below by utility region. A map illustrating the general limits of PEPCO, BGE, and First Energy is provided in Appendix C. Developers should contact MCDOT to verify utility region prior to final design. Site development plans are also subject to review and approval from Montgomery Planning.

### PEPCO Region

Site development projects may approach streetlighting implementation through the four (4) approaches described below:

**1) Streetlighting is furnished and installed by PEPCO at the request of the developer.**

- a) The developer shall contact MCDOT to establish the appropriate light level targets, pole, and fixture types.
- b) The developer shall prepare and submit a photometric plan with a proposed lighting layout that meets the target light levels. If light levels cannot be achieved, justification should be provided. MCDOT will accept the photometric plan for the developer to proceed with lighting design or provide review comments to update photometric analysis.
- c) The developer shall prepare a streetlighting plan illustrating the pole locations, handboxes, and underground conduits, and all relevant existing and proposed geometry, utilities, right-of-way lines, trees, and other pertinent design features that may influence streetlighting design and location. Plans must be submitted in PDF format with the corresponding CAD files in .dgn format. Plans that are incorrect or incomplete will be returned to the developer for revision and resubmission.
- d) The streetlight plans are reviewed and minor revisions, if necessary, are made by MCDOT. All three (3) copies of the plans are approved (as revised). An MCDOT stamp indicating the type, wattage and number of lights will be affixed to each plan and signed as approved by the designated County official.
- e) MCDOT signs and approves streetlighting plans and provides them to the developer with an official letter of approval. A copy of the approval letter is also sent to PEPCO (without plans).
- f) The developer shall submit one (1) copy of the approved streetlight plans to PEPCO with a request for streetlight installation and energization.
- g) PEPCO prepares the streetlight installation/electrical drawings in accordance with the County approved streetlight layout plan and submits a cost estimate to the developer for the installation and energization of the streetlights.
- h) After PEPCO receives payment, the streetlights are scheduled for installation in conjunction with the construction of the subdivision streets. PEPCO advises MCDOT, in writing, when payment is received.

- i) Remittance of payment alone shall not release the developer from lighting responsibility. The developer shall repair any damage to the streetlights following their installation, and prior to County acceptance of the street(s).
- j) Upon notification by the Department of Permitting Services (DPS), which shall be applied for by the developer for release of the paving permit, MCDOT inspects the project to assure that all streetlights have been installed per the approved plans.
- k) Once it is determined that the streetlights have been installed satisfactorily and PEPCO confirms in writing that they have received payment for installation, MCDOT signs the DPS check-off sheet accepting the streetlights for County maintenance.

## **2) Streetlighting is furnished and installed by the developer without streetscaping.**

Follows the same procedures as Part 1, with the following exceptions:

- a) The developer shall furnish and install luminaires, poles, wiring in poles, handboxes, and conduits for streetlighting per the streetlighting plans approved by MCDOT. Wiring shall be installed by the developer from the adjacent handboxes to the luminaires.
- b) The developer shall coordinate with PEPCO for the installation of underground cabling connections and power service.

## **3) Streetlighting is furnished and installed by the developer with streetscaping.**

- a) The developer shall contact MCDOT to establish the appropriate light level targets, pole, and fixture types.
- b) MCDOT provides the developer/consultant with the design standards, equipment specifications, and construction details for the street lighting equipment.
- c) The developer shall prepare and submit a photometric plan with a proposed lighting layout that meets the target light levels. If light levels cannot be achieved, justification should be provided. MCDOT accepts the photometric plan for the developer to proceed with lighting design or provides review comments to update photometric analysis.
- d) The developer shall prepare a streetlighting plan illustrating the pole locations, handboxes, and underground conduits, and all relevant existing and proposed geometry, utilities, right-of-way lines, trees, and other pertinent streetscaping design features that may influence streetlighting design and location. The plans are submitted to MCDOT for review and approval.
- e) The plans are reviewed and minor revisions, if necessary, are made by MCDOT. All three (3) copies of the plans are approved (as revised). An MCDOT stamp indicating the type, wattage and number of lights will be affixed to each plan and signed as approved by the designated County official.

- f) The developer shall provide MCDOT with the approved streetlight plans and the approved streetscape plans with a letter committing the developer to pay PEPCO for the initial costs to energize the streetlights.
- g) The developer shall furnish and install luminaires, poles, wiring in poles, handboxes, and conduits for streetlighting per the streetlighting plans approved by MCDOT. Wiring shall be installed by the developer from the adjacent handboxes to the luminaires.
- h) The developer shall coordinate with PEPCO for the installation of underground cabling connections and power service.
- i) MCDOT submits to PEPCO a written request to energize the new lights with five copies of the approved streetlight plan, and one copy of the developers' commitment to pay letter. The developer should not install conduit prior to receiving the approved electrical plan from PEPCO.
- j) PEPCO determines the source and location of the power connection and provides MCDOT and the developer with the approved electrical plan showing the conduit connection to the power source. PEPCO shall submit an energization cost request to the developer for payment.
- k) The developer/contractor shall install all streetlight fixtures per County standards and install conduits in accordance with the PEPCO's electrical plan and construction standards. The developer/contractor shall coordinate inspection of all underground conduit work with PEPCO prior to backfilling.
- l) Once all streetlight equipment is installed and wired to the bases and after PEPCO has been paid, the developer/contractor shall request PEPCO to energize the streetlights.
- m) Once the streetlights are energized and inspected by MCDOT, the permit will be released and MCDOT will accept the streetlights for County maintenance.

**4) Streetlighting is furnished and installed by PEPCO at the County's request.**

- a) MCDOT prepares a streetlighting plan illustrating the pole locations, handboxes, and underground conduits, and all relevant existing and proposed geometry, utilities, right-of-way lines, trees, and other pertinent design elements, then submits the approved plan to PEPCO with a request for streetlight installation and energization.
- b) PEPCO submits a cost agreement to MCDOT for approval. MCDOT returns the signed cost agreement and encumbers the necessary funds for future payment.
- c) PEPCO schedules the installation of the streetlights and notifies MCDOT when the work has been completed. MCDOT schedules an inspection of the streetlights, authorizes payment, and accepts the streetlight for County maintenance.

## **BGE Region**

Site development projects may approach streetlighting implementation through the two (2) approaches described below:

**1) Streetlighting is furnished and installed by BGE at the request of the developer.**

Streetlighting procedures are the same as PEPCO Region Part 1, except that the streetlighting maintenance is the responsibility of BGE.

**2) Streetlighting is furnished and installed by BGE at the County's request.**

Streetlighting procedures are the same as PEPCO Region Part 4, except that the streetlighting maintenance is the responsibility of BGE.

### **Allegheny Power (FirstEnergy) Region**

Site development projects may approach streetlighting implementation through the two (2) approaches described below:

**1) Streetlighting is furnished and installed by Allegheny Power at the request of the developer.**

Streetlighting procedures are the same as PEPCO Region Part 1, except that the streetlighting maintenance is the responsibility of Allegheny Power.

**2) Streetlighting is furnished and installed by Allegheny Power at the County's request.**

Streetlighting procedures are the same as PEPCO Region Part 4, except that the streetlighting maintenance is the responsibility of Allegheny Power.

## Emerging Technologies

Streetlighting is intended to provide increased traffic safety with a focus on reducing fatal and serious injury crashes throughout the County's transportation network. The County also has a Climate Action Plan aimed at building healthy, equitable, and resilient communities. Appropriate streetlighting helps promote shifts towards active and sustainable modes of transportation by providing safe, comfortable, and inviting public spaces.

The transition to LED light sources from high-intensity discharge (HID) fixtures has significantly reduced the County's energy consumption rates for streetlighting. A strategy for the County to reduce greenhouse gas emissions includes increasing the use of solar energy in the electrical supply. The County will continue to explore and pilot solar streetlighting applications as the technology advances. Streetlighting criteria needs consistent, constant light sources during times of darkness in order to best promote safe travel for all. As energy storage technology advances and photovoltaics improve, the County will consider solar streetlighting applications. Supplement specifications and standard drawings may be incorporated into this document at the discretion of MCDOT.

It is recommended that equipment be compatible with technologies that may be adopted by the County in the future as much as practical. These include wireless connectivity for remote streetlighting control and monitoring and adaptive lighting control. The County continues to pursue investment opportunities to improve road user safety and experience, enhance community spaces, and effectively manage and operate its infrastructure assets.

## Appendix A – Typical Applications

The following illustrates typical applications of streetlighting along Montgomery County roadways.

### Pedestrian-Scale Lighting Along a Pathway



Other examples pending...

# Appendix B – Utility Company Service Areas

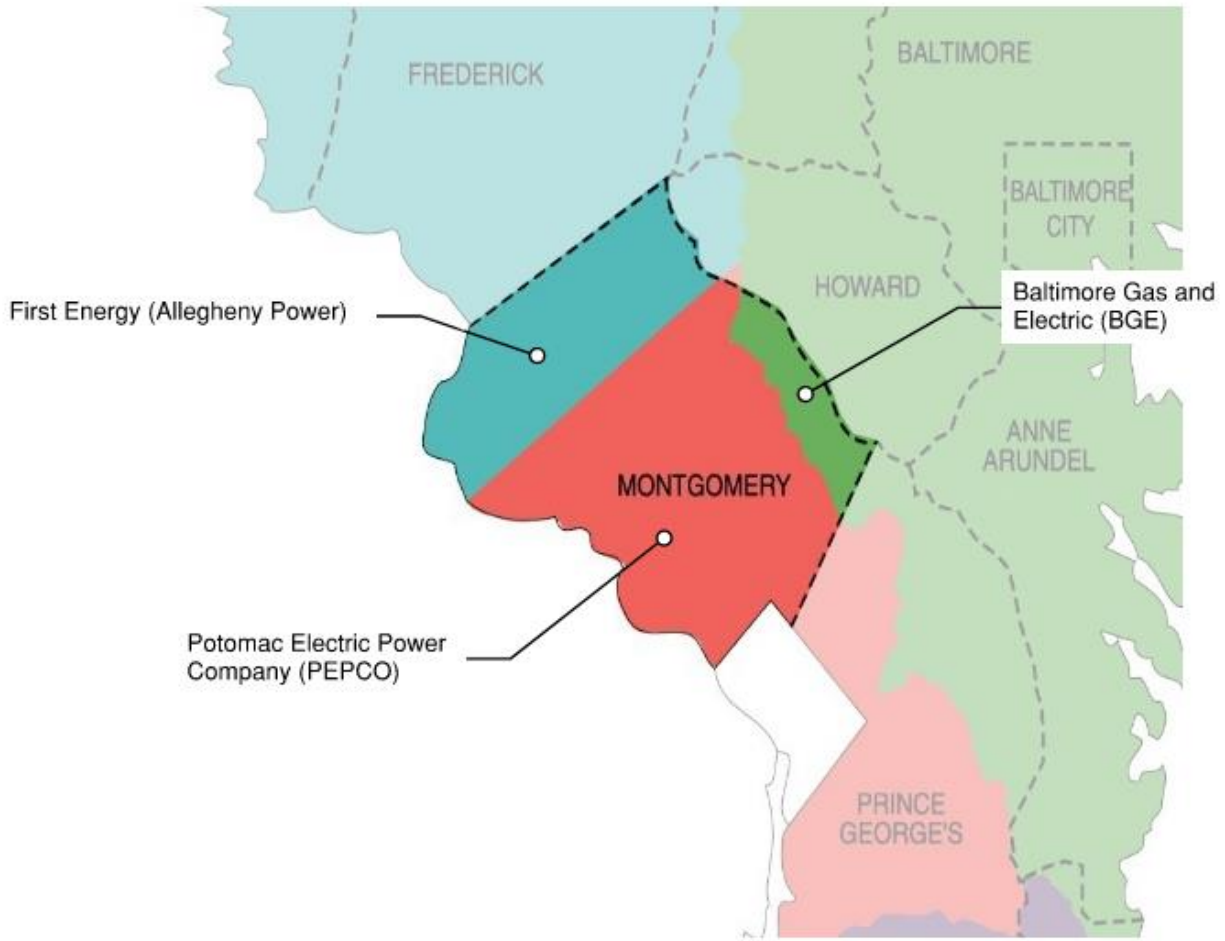



## Appendix C – Streetlighting Specifications

### General

Design Criteria.....	3
Materials.....	3
Finishings.....	4
Maintenance Painting.....	4
Grounding.....	5

### Poles and Posts

12' or 13' Decorative Cast Post .....	6
30' Decorative, Round, Tall Pole.....	9
Decorative Damascus Pedestrian Pole.....	12
Decorative Damascus Vehicular Pole .....	14
13'-2" or 14'-6" Decorative Residential Post.....	16
Residential Lamp Post (Direct Burial).....	20
Fiberglass Roadway Pole .....	22
Decorative Silver Spring Dual Tear Drop Pole .....	24
Decorative Silver Spring Pedestrian Tear Drop Pole.....	27
Decorative Square Steel Pole .....	30
Spun Aluminum Roadway Pole.....	33
40' Square Steel Pole .....	35
Decorative Wheaton Pedestrian Post .....	38
Decorative Wheaton Vehicular Pole .....	40
Transformer Base (Breakaway).....	43

### Fixtures and Luminaires

Cobrahead (Roadway).....	46
Bethesda Globe .....	49
Colonial Post Top.....	51
Washington Globe .....	53
Damascus Pedestrian .....	55
Damascus Vehicular .....	56
Rectilinear (Shoebox).....	58
Silver Spring Pedestrian Tear Drop .....	61



Silver Spring Vehicular Tear Drop .....	63
Contemporary Post Top (Wheaton Pedestrian) .....	65
Wheaton Vehicular Luminaire .....	67
Recessed or Surface Mounted (Wall Pack).....	69
Pedestrian Underpass.....	70
<b>Pole Tags</b>	
Streetlight Pole Numbering Tags .....	71
<b>Small Cell Streetlight Poles</b>	
Telecommunication Small Cell Pole Installations .....	73



## General

### Design Criteria

#### **AASHTO Standards**

All streetlighting structures (poles and lamp posts) shall meet the requirements of the American Association of State Highway and Transportation Officials (AASHTO) *Standard Specifications for Structural Supports for Highway Signs, Luminaires, and Traffic Signals*, latest addition.

#### **Wind Loading**

All streetlighting structures shall be designed to resist (at yield strength of the material without permanent deflection or destruction), test loads equivalent to the calculated wind loads developed by the velocity pressures of an 80-mph wind with a 30% gust factor. A minimum safety factor of 1.82 on the yield strength shall be maintained.

### Materials

Unless otherwise specified, streetlighting materials shall conform to the requirements below.

#### **Cast Iron**

Gray iron castings shall be in accordance with ASTM Standard A48, Class 30B.

#### **Anchor Bolts, Nuts, and Washers for Streetlighting Structures**

Anchor bolts shall be in accordance with ASTM Standard F1554, Grade 55 S1. Anchor bolts shall be galvanized for the full length of the threads and at least 3 inches below the threads.

Nuts shall be heavy hex, carbon steel in accordance with ASTM Standard A194, Grade 2H or A563, Grade DH.

Flat washers and heavy washers shall be in accordance with ASTM Standard F436.

Anchor bolts, nuts, and washers shall be galvanized in accordance with ASTM Standard F2329. High-temperature galvanizing is not acceptable.

#### **Hardware**

Spikes, wood screws, staples, brads, lag screws, carriage bolts, and other parts under general hardware shall be composed of carbon steel in accordance with ASTM F1667.

#### **Conduit**

Conduits and fittings shall conform to Section 921.07 of the *MDOT SHA Standard Specifications for Construction and Materials*.

#### **Structures**

Steel shafts shall meet the requirements of ASTM Standard A595, Grade A. After forming and welding, the shaft shall have a smooth finish with only one longitudinal weld and no transverse welds. Steel bracket arms and mounting brackets shall meet the requirements of ASTM Standard A53, Schedule 40. Structures shall be either mechanically or hot-dipped galvanized.

Aluminum shafts and bracket arms shall be spun from one piece of extruded tubing meeting the requirements of ASTM Standard B241, 6000 T6 Series Alloy.



### **Galvanization**

All iron and steel structures, plates, and reinforcement material requiring galvanization shall be zinc / hot-dipped in accordance with ASTM Standard A123.

### **Stainless Steel Hardware**

All stainless steel hardware shall be high-carbon Type 302 in accordance with ASTM Standard A167 or A240/A240M.

### **Aluminum Castings**

Castings for poles, pedestals, and bases shall use Aluminum Alloy 356-T6 in accordance with ASTM Standard B26 for sand castings or B108 for permanent mold castings.

### **Anchor Base Plate for Aluminum Structures**

Base plates shall use 6000 Series Alloy in accordance with ASTM Standard B209.

### **Finishings**

All visible components shall be finished with a polyester powder coating, fusion bonded, using a thermosetting process. The finish colors shall be:

Hunter Green (Damascus)	SAE AMS-STD-595A	Color 14110
Federal Green	SAE AMS-STD-595A	Color 14036
Gray (Friendship Heights)	SAE AMS-STD-595A	Color 36280
National Park Service Brown	SAE AMS-STD-595A	Color 20040
Semi-Gloss Black (Wheaton)	SAE AMS-STD-595A	Color 27040

### **Application**

1. The coating shall be applied to the cleaned surface as soon as possible after cleaning and before oxidation of the surface discernible to the unaided eye.
2. The mil thickness of the coating after curing shall be six (6) mils plus or minus two (2) mils.
3. The thickness of the coating film shall be measured in accordance with SSPC-PA-2 or other thickness measuring methods acceptable to the purchaser.
4. At random, parts will be checked for adhesion, utilizing the crosscut, tape test.

Alternate finishing techniques may be considered. Complete documentation and specifications for alternate finishes must be submitted together with the results of an accelerated life-testing by an independent laboratory, which certifies an expected life of the alternate finish of at least 20 years.

### **Maintenance Painting**

Spec from Chuck.



## **Grounding**

### Ground Rod

All streetlighting structures shall be provided with a copper ground rod. The ground rod shall have a minimum diameter of 0.625 inch and a minimum length of 10 feet.

### Grounding Lug

All metallic streetlight poles shall be drilled and tapped for a 0.25-inch, #20 grounding screw inside the lamp post and opposite the access door.



## Poles and Posts

### 12' or 13' Decorative Cast Post

#### **Description**

The decorative cast post is made of an integrally cast iron or cast aluminum and finished with a polyester powder coating. This fluted post is intended for use within the Street Buffer Zone along selected roadways in Downtown Bethesda but may be applicable elsewhere in the County. Any manufacturer, distributor, or vendor who submits a bid shall agree to comply with these specifications.

Each pole shall be complete with the following:

- a) Base plate and cover with attaching hardware.
- b) Anchor bolts, nuts, and washers (as specified).
- c) Typical footing design specifications including but not limited to, base template, anchor bolt dimensions, reinforcement, and footer details.
- d) One (1) pint can of touch-up paint matching the finishing color.

#### **Effective Projected Area (EPA)**

The 12' or 13' Decorative Cast Post shall have an EPA allowable for the following assumptions:

- a) Streetlight luminaire shall be assumed to be rectangular in shape with triangular shapes at the top and bottom with a minimum length plus width of 65 inches when viewed from above.
- b) The streetlight luminaire shall have a nominal mounting height of 16 feet above grade.
- c) Up to two (2) traffic signs (24 inches x 36 inches max. surface area per sign) may be mounted with the sign's bottom edge 7 feet above the base.

#### **Materials & Fabrication & Fabrication**

All castings shall be painted with a shop coat of iron oxide primer.

##### Iron Casting

The sections are to be indicated below. The castings are to be true to pattern, with 16 flutes separated by 16 flat facets. All ornamental components shall be cast iron.

The weight of the cast iron post with complete door assembly shall be 460 lbs. ( $\pm 5\%$ ).

##### Aluminum Casting

The lamp post should be cast in one piece, as described above, of aluminum alloy of the same details as described above and minimum wall thickness as described below.

##### Split Casting

The lamp post may be multiple piece castings that are factory-assembled into one piece provided that there are no gaps between any pieces of the assembly that would allow water seepage or rust. Prior written approval required for the method.

#### **Pole**

The entire shaft shall be straight within  $\pm 3/16$  inch along the center axis of the shaft.



Dimensions and wall thickness of the post shaft shall be as follows and as per MC-xxx.xx:

- a) Column at base: 5.75 inches outside diameter and 0.5-inch minimum wall thickness from outer edge of flute to inside wall.
- b) Column at top: 3.25 inches outside diameter and 0.375-inch minimum wall thickness from outer edge of flute to inside wall.
- c) Base at base: 17 inches outside diameter and 0.5-inch minimum wall thickness and 0.875-inch minimum flange thickness.

### **Receptacle**

The post shall incorporate a 15A, 120V, ground fault circuit interrupter (GFCI) duplex receptacle with a waterproof cover, painted to match the post. Receptacle shall be located 180 degrees from traffic flow and 6 inches from the bottom of the tenon.

### **Height**

The height of the post, less tenon, shall be 12 feet for cast iron or 13 feet for cast aluminum.

### **Tenon**

The top of the post shall be equipped with a luminaire mounting tenon integrally cast as a part of the post casting. The tenon shall measure 3 inches outside diameter and 3 inches long for cast aluminum posts, or 3.5 inches outside diameter and 3.5 inches long for cast iron posts.

### **Handhole**

The post shall have an handhole provided in the base of the lamp post secured with stainless steel machine screw. The handhole shall have a minimum opening 7 inches high, 2.75 inches wide at the top, and 7 inches wide at the bottom.

### **Bottom Access Hole**

The base of the decorative cast post shall have an inside diameter sufficient to accommodate two (2) 4-inch diameter, Schedule 40 PVC conduits at the bottom of the post, side by side, for streetlight wiring in accordance with utility company requirements.

### **Bolt Circle**

The nominal bolt circle of the post shall be 12 inches in diameter and consist of four (4) equally spaced slots. Each slot shall accommodate one (1) 0.75-inch diameter anchor bolt.

### **Anchor Bolts**

Each decorative cast post shall be supplied with four (4) steel anchor bolts. The anchor bolts shall have a diameter of 0.75 inch, a minimum length of 24 inches plus a 3-inch "L" at the bottom for cast iron posts, or a minimum length of 36 inches plus a 3-inch "L" at the bottom for cast aluminum posts. Bolts shall have minimum of 6 inches of thread at the top. Each anchor bolt shall be furnished with one (1) hexagonal nut and one (1) washer for plumbing and securing the pole as necessary.

### **Finish**

#### Cast Aluminum

The decorative cast aluminum post, access doors, and hardware shall be finished with an electrostatically applied thermoset polyester powder coat or approved equal.



Cast Iron

The decorative cast iron posts and all components shall be supplied with one (1) coat of oil-based red lead primer paint. Two (2) coats of enamel shall be applied to each pole in the field.

**Pole Information**

The decorative cast post shall be Spring City Washington #13 or approved equal.





### **30' Decorative, Round, Tall Pole**

#### **Description**

The bronze-colored, round, tapered, steel, decorative tall poles are intended for use along Montgomery County roadways. Any manufacturer, distributor, or vendor who submits a bid shall agree to comply with these specifications and the attached drawings.

Each pole shall be complete with the following:

- a) Base plate and cover with attaching hardware.
- b) Pole top cover with attaching hardware.
- c) J-hook inside top of pole.
- d) Anchor bolts, nuts, and washers (as specified).
- e) Typical footing design specifications including, but not limited to, base template, anchor bolt dimensions, reinforcement, and footer details.
- f) "National Park Service Brown" finishing.

#### **Effective Projected Area (EPA)**

The decorative tall post streetlight pole shall have an EPA allowable for the following assumptions:

- a) Streetlight luminaire shall be assumed to be rectangular in shape, minimum length plus width of 36 inches, with a side-mounted bracket arm 8 to 12 inches in length.
- b) One or two streetlight luminaires may be mounted on each tall post streetlight pole. The two configurations of dual luminaire mounting shall be: Opposite arrangement (180 degrees) or Right-Angle arrangement (90 degrees).
- c) The streetlight luminaire shall have a nominal mounting height of 25 feet or 30 feet above the base.
- d) One (1) traffic sign (24 inches x 36 inches max. surface area per sign) may be mounted with the sign's bottom edge 7 feet above the base.

#### **Materials & Fabrication**

All castings used to complete the tall post streetlight pole shall be clean and smooth with details well defined and true to pattern. Steel castings shall conform to ASTM A27, Grade 65-35. Gray iron castings shall conform to ASTM A126, Class A.

The tapered shaft shall be made of a single sheet of Manufacturers' Standard Gauge No. 11 (minimum) steel.

No transverse joints or welds are permitted. The one (1) longitudinal weld shall be fusion-welded and ground or cold-rolled smooth.

#### **Pole**

Each shaft shall have a round, circular cross-section with an outside base diameter of 7 inches, and with a uniform taper decreasing from the base at a rate of 0.14 inches per foot of height.

The curvature (for straightness) shall not exceed 0.5 inch in any 10-foot portion of the total length.



### **Height**

The shaft shall have a length sufficiently long to provide a mounting height of  $\pm 25$  feet from the base of the luminaire (nominal length of 26 feet).

### **Handhole**

The tall-post streetlight pole shall be supplied with a 4-inch wide by 8-inch high semi-flush reinforced handhole opening located a minimum of 8 inches above the baseplate. Each pole shall be equipped with a cover plate for the handhole constructed of a minimum 11-gauge steel, to be attached to the streetlight pole with two (2) tamper-proof screws and retained to the streetlight pole by an 18-inch long stainless steel chain affixed to both the cover plate and the tall-post streetlight pole.

### **Luminaire Mounting**

Each tall-post streetlight pole shall be factory drilled for one set of holes necessary to mount the luminaire so that the bottom of the luminaire is 25 feet above the base. The set of factory-drilled mounting holes shall be 90 degrees to the left of the plane of the hand hole when the pole is viewed from above.

A J-hook shall be welded to the inside of the streetlight pole opposite to and above the mounting holes for the luminaire.

### **Bottom Access Hole**

The base of the streetlight pole shall have an inside diameter sufficient to accommodate two (2) 4-inch diameter, Schedule 40 PVC conduits at the bottom of the post, side by side, for streetlight wiring in accordance with utility company requirements.

### **Base Plate**

A minimum 1-inch thick steel base plate sufficient to fully develop the ultimate strength of the tall-post streetlight pole shall be secured to the base of the pole-shaft with two (2) self-closing transverse welds at the following locations:

- On the inside of the base at the bottom of the pole-shaft.
- At the top of the baseplate.

The base shall telescope into the pole-shaft. The baseplate may either be circular in shape with rounded corners and a nominal dimension of 15 inches or square in shape with rounded corners and a nominal dimension of 15 inches per side.

### **Bolt Circle**

The nominal bolt circle of the post shall be 12.5 inches in diameter and consist of four (4) equally spaced slots. Each slot shall have a width of 1.25 inches to accommodate one (1) 1-inch diameter anchor bolt. The slots shall be able to accommodate bolt circles from 12 to 13 inches.

### **Anchor Bolts**

Each pole shall be supplied with four (4) steel anchor bolts. The anchor bolts shall have a diameter of 1 inch, a minimum length of 36 inches plus a 4-inch "L" bend at the bottom and a minimum of 6 inches of thread at the top. Each anchor bolt shall be furnished with two (2) hexagonal nuts and two (2) flat washers for plumbing and securing the pole as necessary.



### **Finish**

All visible components shall then be finished to produce the appearance of a decorative SAE AMS-STD-595A, Color 20040, National Park Service Brown.

For each tall-post supplied, one (1) 14-ounce spray can, to match the color of the tall post streetlight pole shall be provided.

### **Pole Information**

These specifications are intended to produce a uniform system of hardware that will minimize the number of stock items that the County or its contractor(s) must maintain. The tall post streetlight pole shall be capable of being mounted on the foundation of a decorative cast lamp post (i.e., four (4) 0.75-inch diameter anchor bolts on a 12.5-inch diameter bolt circle).



## Decorative Damascus Pedestrian Pole

### **Description**

The Decorative Damascus Pedestrian Pole is intended for use in medians and at curbsides in rural and urban streetscape areas. Damascus streetlighting luminaires may also be wall mounted. Any manufacturer, distributor, or vendor who submits a bid shall agree to comply with these specifications and the attached drawings.

Each pole shall be complete with the following:

- a) Base plate with decorative cover and attaching hardware.
- b) Arched luminaire arm with attaching hardware.
- c) Anchor bolts, nuts, and washers (as specified).
- d) Typical footing design specifications including but limited to, base template, anchor bolt dimensions, reinforcement, and footer details.

### **Materials & Fabrication**

The pole shall be 6063-T4 Aluminum Alloy with 0.125-inch wall thickness.

### **Pole**

The shaft of the pole shall be tapered from a 5-inch diameter at the pedestal to a 3-inch diameter at the tenon.

### **Receptacle**

The pole shall incorporate two (2) 15A, 120V, ground fault circuit interrupter (GFCI) duplex receptacles with waterproof covers, painted to match the pole. Receptacles shall be located 180 degrees from one another and 90 degrees from traffic flow. Receptacles shall be mounted 9 inches from the bottom of the tenon.

### **Height**

The length of the pole shall be 12 feet from the bottom of the base to the beginning of the arm bracket mount.

### **Pedestal**

The pedestal dimensions shall be 14.25 ( $\pm 1.0$ ) inches wide at the base and 44 ( $\pm 1.0$ ) inches in height. The pedestal cover shall be included and shall be square in shape with a nominal dimension of 14 inches per side. The pedestal shall be a cast aluminum with an access door.

### **Tenon**

Need information.

**Commented [WW1]:** Chuck - is there tenon info we need to add here? The bracket arm looks like it maybe uses a tenon.

### **Handhole**

The handhole shall be 4.375 inches x 5.75 inches. Included is a steel cover with attachment screws. A nut holder is welded to the handhole and includes a 0.5-inch - # 13UNC hex head bolt and nut for grounding. The handhole is located 6 inches above the base and 90 degrees clockwise with respect to the luminaire arm when viewed from above the pole. The handhole cover shall be retained by a chain permanently attached to the pole.

**Commented [NM2]:** Should additional info such as the example text be added? If so, please specify



### **Luminaire Mounting**

The pole shall have an arched aluminum arm bracket. The arm shall be a 1.5-inch Schedule 40 diameter aluminum tubing. The arm bracket shall be 6063-T52 Aluminum Alloy that has been modified for a 3-inch pole mount. The arched tubing shall be constructed of a 1.5-inch diameter aluminum tubing. The tubing shall have a maximum height of 15 feet above sidewalk grade. The tubing shall arch 180 degrees into the top of the luminaire. The arch shall be continuous and smooth. The tubing shall maintain the luminaire nominal mounting height of 12 feet above sidewalk grade level.

### **Base Plate**

The base plate shall be a minimum 0.75 inch thick of B135 alloy cast aluminum. It shall be pre-drilled with bolt circles as specified by the manufacturer.

### **Anchor Bolts**

Each pole shall be supplied with four (4) steel anchor bolts. The anchor bolts shall have a diameter of 0.75 inch, a minimum length of 24 inches plus a 4-inch "L" bend at the bottom and a minimum of 6 inches of thread at the top. Each anchor bolt shall be furnished with one (1) hexagonal nut and one (1) flat washer for plumbing and securing the pole as necessary.

### **Finish**

The entire pole and luminaire shall be finished by the luminaire manufacturer at the factory with the painting process to be Thermoset polyester powder coat that is electrostatically applied after a five-stage conversion cleaning process and bonded by heat fusion thermosetting. This finish should be laboratory tested for superior weatherability and fade resistance in accordance with ASTM B-117-64 and ANSI/ASTM G53-77 specifications.

### **Photocell**

The photocell shall be a button eye type 3,000 tork or equal with a shield that is mounted just below the receptacle on the pole, facing away from the luminaire.

### **Wall Bracket**

Where necessary the luminaires shall be mounted on an arched aluminum wall bracket. Refer to Luminaire Mounting and Finish of this section for information regarding the luminaire arm and finish.



## **Decorative Damascus Vehicular Pole**

### **Description**

The Decorative Damascus Vehicular Pole is intended for use in medians and at curbsides in rural and urban streetscape areas. Any manufacturer, distributor, or vendor who submits a bid shall agree to comply with these specifications and the attached drawings. Each pole shall be complete with the following:

- a) Base plate and cover with attaching hardware.
- b) Anchor bolts, nuts, and washers (as specified).
- c) Typical footing design specifications including but limited to, base template, anchor bolt dimensions, reinforcement, and footer details.
- d) "National Park Service Brown" finishing.

### **Materials & Fabrication**

The tapered shaft shall be made of a single length sheet of Manufacturers' Standard Gauge No. 11 (minimum) steel.

### **Pole**

The diameter of the shaft at the base shall be 6.4 inches tapering to 2.4 inches at the top. The shaft is cylindrical in cross-section with a uniform taper of approximately 0.14 inch of diameter change per linear foot.

The pole shall have a continuous davit arm. The davit shall be smooth and continuous, for the entire length of the pole shaft.

### **Height**

The pole shall hold the luminaire at  $\pm 25$  feet above grade, and the arm extend shall no farther than 6 feet from the pole.

### **Handhole**

The Damascus vehicular streetlight pole shall be supplied with a 3-inch wide by 5-inch high handhole opening located 6 inches above the base and 90 degrees clockwise with respect to the luminaire arm when viewed from above the pole. There shall be a reinforced handhole in the pole shaft. The opening shall be circumferentially welded in the pole shaft. Each pole shall be equipped with a cover plate for the handhole constructed of a minimum 11-gauge steel, to be attached to the streetlight pole with two (2) tamper-proof screws and retained to the streetlight pole by an 18-inch long stainless steel chain affixed to both the cover plate and the tall-post streetlight pole. Included is a steel cover with attachment screws. A nut holder is welded to the handhole and includes a 0.5-inch - #13UNC hex head bolt and nut for grounding.

### **Bolt Circle**

The nominal bolt circle of the lamp post shall be 9.5 inches in diameter and consist of four (4) equally spaced slots to accommodate 1-inch diameter anchor bolts.



### **Base Plate**

The anchor base shall be a carbon steel plate and telescope the pole shaft. The base plate shall be circumferentially welded top and bottom. The base plate shall be provided with slotted bolt holes to accommodate a variation in the nominal bolt circle as charted.

The base plate cover shall be fabricated from carbon steel. The base plate cover shall be a two-piece cover secured together with two painted hex head screws. The cover shall conceal the entire base plate and anchor bolts.

### **Anchor Bolts**

Each pole shall be supplied with four (4) steel anchor bolts. The anchor bolts shall have a diameter of 1 inch, a minimum length of 36 inches plus a 4-inch "L" bend at the bottom and a minimum of 6 inches of thread at the top. Each anchor bolt shall be furnished with one (1) hexagonal nut and one (1) flat washer for plumbing and securing the pole as necessary.

### **Finish**

The poles shall be finish painted "National Park Service Brown." All poles shall have all detrimental weld flux slag deposits mechanically removed. All rust, moisture, oil, grease, loose paint or any foreign material then shall be removed prior to undercoat painting per Steel Structures Painting Council (SSPC) Specification #SSPC-YIS1. The color shall be SAE Standard AMS-STD-595A, Color 20040. The minimum finish paint coat thickness shall be 2.0 mils.



## **13'-2" or 14'-6" Decorative Residential Post**

### **Description**

The decorative residential posts are intended for use along roadways in Montgomery County. A 14-foot 6-inch post shall be used along Oaklyn Drive in the vicinity of Avenel Local Park in Potomac. A 13-foot 2-inch post should be used for other neighborhood roadways. Any manufacturer, distributor, or vendor who submits a bid shall agree to comply with these specifications and the attached drawings.

Each pole shall be complete with the following:

- a) Base plate and cover with attaching hardware.
- b) Anchor bolts, nuts, and washers (as specified).
- c) Typical footing design specifications including but not limited to, base template, anchor dimensions, reinforcement, and footer details.
- d) One (1) pint of touch-up paint, SAE Standard AMS-STD-595A, Color 14036, Federal Green.

### **Effective Projected Area (EPA)**

The decorative tall post streetlight pole shall have an EPA allowable for the following assumptions:

- a) Streetlight luminaire shall be assumed to be rectangular in shape with triangular shapes at the top and bottom, minimum length plus width of 65 inches, when viewed from above.
- b) For the Oaklyn Drive 14-foot 6-inch post, the streetlight luminaire shall have a nominal mounting height of 14 feet 6 inches above the base.
- c) For the standard 13-foot 2-inch post, the streetlight luminaire shall have a nominal mounting height of 12 feet above the base.
- d) Up to two (2) traffic signs (24 x 36 inches max. surface area per sign) may be mounted with the sign's bottom edge 7 feet above the base.

### **Materials & Fabrication**

All castings shall be painted with a shop coat of iron oxide primer.

#### Iron Casting

The lamp post shall be integrally cast as one piece. The sections are to be indicated below. The castings are to be true to pattern, with 16 flutes separated by 16 flat facets. There shall be no visible signs of separation between the cope and drag sections of the mold. All ornamental components shall be cast iron.

The weight of the cast iron post with complete door assembly shall be 460 lbs. ( $\pm 5\%$ ). All castings shall be painted with a shop coat of iron oxide primer.

#### Aluminum Casting

The lamp post may be cast in one piece, as described above, of aluminum alloy of the same details as described above and minimum wall thickness as described below.





#### Split Casting

The lamp post may be multiple piece castings that are factory-assembled into one piece, provided that there are no gaps between any pieces of the assembly that would allow water seepage or rust. Prior written approval required for this method.

#### **Pole**

The outer portion of each flute shall have a flat face, 0.375 ( $\pm 1/16$ ) inches in width. The flutes shall remain constant from the top to the bottom of the tapered shaft.

#### Oaklyn Drive 14'-6" Post

The shaft shall taper uniformly from 7 inches outside diameter at the bottom to a minimum of 4.5 inches outside diameter at the top. The shaft section shall consist of sixteen (16) equally spaced flutes.

#### Standard 13'-2" Post

The shaft shall taper uniformly from 6 inches outside diameter at the bottom to a minimum of 4 inches outside diameter at the top. The shaft section shall consist of sixteen (16) equally spaced flutes.

#### **Height**

#### Oaklyn Drive 14'-6" Post

The height of the post, less tenon, shall be 14 feet 6 inches.

#### Standard 13'-2" Post

The height of the post, less tenon, shall be 12 feet.

#### **Tenon**

The top of the post shall be equipped with a luminaire mounting tenon integrally cast as a part of the post casting.

#### Oaklyn Drive 14'-6" Post

The tenon shall measure 3.25 ( $\pm 0.25$ ) inches outside diameter and be 3 inches long.

#### Standard 13'-2" Post

The tenon shall measure 3.25 ( $\pm 0.25$ ) inches outside diameter and be 3 inches long.

#### **Handhole**

The lamp post shall be supplied with a handhole/access door in the base of the lamp post. The handhole shall be secured with a stainless steel machine screw at the base of the lamp post. The handhole shall be set 45 degrees from the direction of travel.

#### Oaklyn Drive 14'-6" Post

The opening shall have a minimum opening of 7 inches high and a minimum of 2.75 to 4.5 inches wide at the top and 7.5 ( $\pm 0.5$ ) inches wide at the bottom.

#### Standard 13'-2" Post

The opening shall have a minimum opening of 6 ( $\pm 0.5$ ) inches high and a minimum of 3.5 ( $\pm 1.0$ ) inches wide at the top and 7.5 ( $\pm 1.0$ ) inches wide at the bottom. The handhole shall be secured with a stainless steel machine screw at the base of the lamp post.



### **Pedestal**

The pedestal shall be 24 ( $\pm 0.25$ ) inches in diameter with a height of 24 ( $\pm 1.0$ ) inches.

### **Bottom Access Hole**

The base of the streetlight pole shall have an inside diameter sufficient to accommodate two (2) 4-inch diameter, Schedule 40 PVC conduits at the bottom of the post, side by side, for streetlight wiring in accordance with utility company requirements.

The pedestal shall have a clear opening of 11 inches (minimum) in diameter at grade.

### **Bolt Circle**

The nominal bolt circle of the lamp post shall be 17 inches in diameter and consist of four (4) equally spaced slots to accommodate 0.75-inch diameter anchor bolts.

### **Anchor Bolts**

Each pole shall be supplied with four (4) steel anchor bolts. Each anchor bolt shall be furnished with one (1) hexagonal nut and one (1) flat washer for plumbing and securing the pole as necessary.

The anchor bolts shall have a diameter of 0.75 inch, a minimum length of 36 inches plus a 4-inch "L" bend at the bottom and a minimum of 6 inches of thread at the top.

### **Finish**

#### Cast Aluminum

The cast aluminum pole, access door, and hardware shall be finished with a dark green electrostatically-applied thermoset polyester powder coat, SAE Standard AMS-STD-595A, Color 14036, Federal Green. One (1) pint can of Federal Green touch-up enamel shall be supplied with each pole.

#### Cast Iron

The cast iron pole and all components shall be supplied with one coat of oil-based red lead primer paint. Two (2) coats of enamel SAE Standard AMS-STD-595A, Color 14036, Federal Green shall be applied to each pole in the field.

### **Pole Information**

#### Oaklyn Drive 14'-6" Post

The lamp post shall be either the Antique Capitol Series, C15/24-CI/PP, the Washington #16 Standard modified to 14 feet 6 inches in height, less tenon, or approved equal.

#### Standard 13'-2" Post

The lamp post shall be either the Antique Capitol Series, C12/17-CI/PP, the Washington #12 Standard modified to 14 feet 6 inches in height, less tenon, or approved equal.

### **Tolerances**

Dimensions may be subject to a tolerance of plus or minus 10%, provided that the appearance and proportions are reasonably identical to the post shown on the attached drawing, in the sole judgement of the County. The 10% tolerance shall not apply to the height of the post nor to



the diameter of the tenon, for which no tolerance will be allowed other than normal manufacturing tolerances



## **Residential Lamp Post (Direct Burial)**

### **Description**

The decorative direct burial, fiberglass streetlight post (fluted and round) shall be made of a fiberglass reinforced composite (fiberglass filament and color pigmented resin), with a polyurethane and UV inhibitor coating, with a natural finish.

The fluted streetlight posts are intended for use along roadways in Montgomery County. The round, tapered streetlight posts are intended for use on neighborhood roadways, pathways, and tunnels throughout Montgomery County. Any manufacturer, distributor, or vendor who submits a bid shall agree to comply with these specifications and the attached drawings.

Each pole shall be complete with the following:

- a) Handhole and cover plate (as specified).
- b) Rubber grommeted conductor entrance.

### **Effective Projected Area (EPA)**

The decorative tall post streetlight pole shall have an EPA allowable for the following assumptions:

- a) Streetlight luminaire shall be assumed to be rectangular in shape with triangular shapes at the top and bottom, minimum length plus width of 65 inches, when viewed from above.
- b) The streetlight luminaire shall have a nominal mounting height of 12 feet above the ground.
- c) One or two traffic signs (24 inches x 36 inches max. surface area per sign) may be mounted with the sign's bottom edge 7 feet above the base.

### **Materials & Fabrication**

The fiberglass direct burial decorative residential streetlight post shall be constructed by a winding filament process with color pigmented polyester resin impregnated into the filaments. The filament winding shall be continuously applied with uniform tension.

The resin used will be color pigmented and shall be ultraviolet resistant. A highly weather resistant pigmented polyurethane coating shall be applied to the pole at a minimum thickness of 1.5 mils.

### **Pole**

#### **Fluted Shaft**

The fluted shaft shall taper uniformly from 6.5-inch outside diameter at the bottom to a minimum of 4.5-inch outside diameter at the top. The shaft section shall consist of sixteen (16) equally spaced flutes. The outer portion of each flute shall have a flat face, 0.375 inches in width. The flutes shall remain constant from the top to the bottom of the tapered shaft.

#### **Round Shaft**

The round shaft shall taper uniformly from 5.5-inch ( $\pm 0.1$ ) outside diameter at the bottom to a minimum 2.9-inch ( $\pm 0.1$ ) outside diameter at the top. The shaft section shall consist of sixteen (16) equally spaced flutes.



## **Height**

### Fluted Shaft

The height of the post, less tenon, shall be 16 feet. The post shall have 12 feet of exposed post above the ground and 4 feet of embedded post in the ground, as shown in the drawing.

### Round Shaft

The height of the post shall provide a nominal luminaire mounting height between 12 feet and 14 feet above the surrounding ground elevation. The shaft shall be embedded a minimum of 3 feet in the ground.

## **Tenon**

The decorative residential streetlight pole shall have a permanently bonded, hot-dipped galvanized steel or aluminum, 3-inch tenon.

## **Handhole**

The handhole shall be supplied with a non-metallic cover secured with two (2) tamper-resistant stainless steel machine screws. The pole shall be supplied with a 2.5-inch wide by 5-inch high handhole opening located between 6 inches and 18 inches above the groundline measured to center of handhole.

## **Access Holes**

The post shall have two (2) access holes located approximately  $\pm 24$  inches below the ground line. The access holes for wiring shall be opposite each other and shall have rubber grommets provided for each access hole. The access holes shall have a minimum opening of 2.25 inches in diameter.

## **Finish**

The direct burial, fiberglass pole shall be of a natural finish for the entire length of the pole.



## **Fiberglass Roadway Pole**

### **Description**

The roadway, round, tapered, direct burial fiberglass poles are intended for use along roadways in Montgomery County. Any manufacturer, distributor, or vendor who submits a bid shall agree to comply with these specifications and the attached drawings.

Each pole shall be complete with the following:

- a) Pole top cover with attaching hardware.
- b) Handhole and cover plate (as specified).
- c) 6-foot aluminum mast arm with attaching hardware.
- d) Rubber grommeted conductor entrance.

### **Effective Projected Area (EPA)**

The decorative tall post streetlight pole shall have an EPA allowable for the following assumptions:

- a) Streetlight luminaire shall be assumed to be near rectangular in shape and a minimum (length plus height) of 36 inches on the mounting bracket arm.
- b) The streetlight luminaire shall have a nominal mounting height of 25 feet above the base.
- c) Up to two (2) traffic signs (24 x 36 inches max. surface area per sign) may be mounted with the sign's bottom edge 7 feet above the base.

### **Materials & Fabrication**

The direct burial fiberglass pole shall be constructed by a winding filament process with color pigmented polyester resin impregnated into the filaments. The filament winding shall be continuously applied with uniform tension.

The resin used will be color pigmented and shall be ultraviolet resistant. A highly weather resistant pigmented polyurethane coating shall be applied to the pole at a minimum thickness of 2.0 mils.

### **Pole**

The fiberglass shaft shall have a round, circular cross-section with a minimum outside base diameter of 8 inches, and with a uniform taper decreasing from the base at a rate of 0.1 inch (minimum) to 0.14 inch (maximum) per foot of height.

### **Pole Top Cap**

The direct burial fiberglass streetlight pole shall include a removable pole cap to allow for servicing and maintenance.

### **Height**

The streetlight luminaire shall have a nominal mounting height of 25 feet above the base.

The fiberglass mast shall have a shaft with sufficient length to allow a minimum of 5 feet to be embedded into the surrounding soil.



### **Handhole**

The fiberglass, roadway streetlight pole shall be supplied with a peripherally reinforced, flush, covered handhole. The handhole opening at minimum shall be 2.5-inch width by 5-inch height oval. The handhole shall be located a maximum of 18 inches above the groundline and at a 90-degree clockwise angle with respect to the luminaire bracket arm.

### **Luminaire Mounting**

The fiberglass, roadway streetlight pole shall include one (1) 6-foot tapered arm with attachment plate. The bracket arm shall have a 1.5-inch or 2-inch slipfitter at the end for the installation of the luminaire.

- a) The bracket arm shall be fabricated from aluminum tubing.
- b) The bracket arm mounting shall be predrilled so that it can transfer the maximum strength to the shaft. The attachment plate shall be curved to the shape of the pole and have a minimum of two (2) bolts and two (2) curved washers securing system.

### **Finish**

The direct burial fiberglass pole shall be of a natural finish for the entire length of the pole.



## **Decorative Silver Spring Dual Tear Drop Pole**

### **Description**

The decorative tear drop pole is intended for use along roadways in Downtown Silver Spring. Any manufacturer, distributor, or vendor who submits a bid shall agree to comply with these specifications and the attached drawings.

The Decorative Silver Spring Dual Tear Drop Pole shall consist of a steel shaft and integrally cast aluminum luminaire mounting arms and finished with a polyester powder coating. The pole shall be designed to provide aesthetically pleasing and practical means of supporting two luminaires. The luminaires mounted are to be one (1) Silver Spring vehicular teardrop luminaire at a mounting height of 26 foot 1.5 inches and one (1) Silver Spring pedestrian teardrop luminaire at a mounting height of 15 foot 7 inches from the base.

Each pole shall be complete with the following:

- a) Base plate with attachment hardware.
- b) Pedestal base cover.
- c) Luminaire mast arms with attaching hardware.
- d) Anchor Bolts, nuts, and washers (as specified).
- e) Typical footing design specifications including but not limited to, base template, anchor dimensions, reinforcement, and footer details.
- f) One (1) pint of touch-up paint matching the finishing color.

### **Effective Projected Area (EPA)**

The decorative tall post streetlight pole shall have an EPA allowable for the following assumptions:

- a) Streetlight (vehicular) luminaire shall be assumed to be rounded in shape with triangular shapes at the top and bottom, minimum length plus width of 51 inches, when viewed from the side.
- b) Streetlight (pedestrian) luminaire shall be assumed to be rounded in shape with triangular shapes at the top and bottom, minimum length plus width of 48 inches, when viewed from the side.
- c) The streetlight (vehicular) luminaire shall have a nominal mounting height of 26 feet ( $\pm 6$  inches) above the base.
- d) The streetlight (pedestrian) luminaire shall have a nominal mounting height of 16 feet ( $\pm 6$  inches) above the base.
- e) Two (2) traffic signs (24 x 36 inches max. per sign) may be mounted with the sign's bottom edge 7 feet above the base.
- f) Two (2) 0.5-inch diameter banner mounting arm and bracket may be mounted with the aluminum shaft located 13 feet above the base.

### **Materials & Fabrication**

The pedestal base shall be made of cast aluminum or cast iron.

The pole shaft shall be made of 11-gauge fluted steel with steel anchor plate. The steel flutes are to be true to pattern, with 12 flutes separated by 12 flat facets.





The luminaire mounting arms shall aluminum with cast aluminum fittings.

All mounting hardware shall be tamper-resistant, stainless steel.

### **Pole**

The shaft shall have an outside diameter of 10.4 inches at the anchor plate and taper at 0.14 inch per foot, uniformly. The shaft section shall consist of twelve (12) equally spaced flutes. The outer portion of each flute shall have a flat face, 0.375 ( $\pm 1/16$ ) inches in width. The flutes shall remain constant from the top to the bottom of the tapered shaft.

### **Receptacle**

12A, 120V outlet with weatherproof cover should be mounted 18 feet 9 inches above grade oriented towards the downstream side of the travel way.

### **Height**

The height of the post, less tenon, shall be 21 feet 3.5 inches, with the welded plate for the bolt on luminaire arm placed at 14 feet from the base.

### **Tenon**

The top of the post shall be equipped with a tenon to install a smooth, curved, and tapered luminaire mounting arm. The tenon shall measure 4.5 ( $\pm 0.25$ ) inches outside diameter and 10 inches in length.

### **Handhole**

The dual, decorative pole shall be supplied with at least one (1) handhole/access door at the base. The handhole door shall be secured with tamper-resistant, stainless steel machine screws.

### **Luminaire Mounting**

#### Upper Luminaire Arm

The upper luminaire arm shall rise 58 inches and measure 51 inches from pole center to luminaire center with a fitting to accept the Silver Spring, vehicular, teardrop-style luminaire.

#### Lower Luminaire Arm

The bolt on luminaire arm mounting plate shall be located 14 feet from the base.

The lower luminaire arm shall rise 24 inches and measure 48 inches from mounting plate to luminaire center with a fitting to accept the Silver Spring, pedestrian, teardrop-style luminaire.

### **Pedestal**

The pedestal shall measure 22 ( $\pm 0.25$ ) inches in diameter with a height of 36 ( $\pm 0.25$ ) inches. The pedestal may be cast as one or two pieces. The castings are to be true to pattern. There shall be no visible signs of separation between the cope and drag sections of the mold. All ornamental components shall be cast aluminum. The pedestal shall have two (2) SILVER SPRING MEDALLIONS (See Standard Drawing for details) mounted at 90 degrees and 270 degrees from the handhole access door.

### **Bottom Access Hole**

The pedestal shall have a clear opening of 10 inches (minimum) in diameter at grade. The base of the dual, decorative pole shall have an inside diameter sufficient to accommodate two (2) 4-



inch diameter, Schedule 40 PVC conduits at the bottom of the post, side by side, for streetlight wiring in accordance with utility company requirements.

**Bolt Circle**

The nominal bolt circle of the lamp post shall be 15 inches in diameter and consist of four (4) equally spaced slots to accommodate 1.25-inch diameter anchor bolts.

**Base Plate**

The base plate shall be 1.5 inch thick and square in shape with rounded corners and a nominal dimension of 16 inches per side. The base plate shall be continuously welded to the shaft.

**Anchor Bolts**

Each pole shall be supplied with four (4) steel anchor bolts. The anchor bolts shall have a diameter of 1.25 inches, a minimum length of 48 inches plus a 3-inch "L" bend at the bottom and a minimum of 6 inches of thread at the top. Each anchor bolt shall be furnished with two (2) hexagonal nuts and two (2) flat washers for plumbing and securing the pole as necessary.

**Finish**

The steel and cast aluminum poles, access doors, and hardware shall be finished with a dark green electrostatically applied thermoset polyester powder coat, SAE Standard AMS-STD-595A, Color 14036, Federal Green or approved equal. One (1) pint can of Federal Green touch-up enamel or approved equal, shall be supplied.

**Pole Information**

The streetlight structure shall be based on King Luminaire pole model KSSFF-21 C/W KSB76 with arms KA114 and KA204, or approved equal.



## **Decorative Silver Spring Pedestrian Tear Drop Pole**

### **Description**

The decorative tear drop pole is intended for use along roadways in Downtown Silver Spring. Any manufacturer, distributor, or vendor who submits a bid shall agree to comply with these specifications and the attached drawings.

The Decorative Silver Spring Pedestrian Tear Drop Pole shall consist of a steel shaft and integrally cast aluminum luminaire mounting arm, finished with a polyester powder coating. The post shall be designed to provide aesthetically pleasing and practical means of supporting the Silver Spring pedestrian, teardrop-style luminaire at a mounting height of 15 foot 7 inches from the base.

Each pole shall be complete with the following:

- a) Base plate with attachment hardware.
- b) Pedestal cover.
- c) Luminaire mast arm with attaching hardware.
- d) Anchor Bolts, nuts, and washers (as specified).
- e) Typical footing design specifications including but not limited to, base template, anchor dimensions, reinforcement, and footer details.
- f) One (1) pint of touch-up paint matching the finishing color.

### **Effective Projected Area (EPA)**

The decorative tall post streetlight pole shall have an EPA allowable for the following assumptions:

- a) Streetlight (pedestrian) luminaire shall be assumed to be rounded in shape with triangular shapes at the top and bottom, minimum length plus width of 40 inches, when viewed from the side.
- b) The streetlight luminaire shall have a nominal mounting height of 15 feet 7 inches above the base.
- c) Up to two (2) traffic signs (24 x 36 inches max. per sign) may be mounted with the sign's bottom edge 7 feet above the base.

### **Materials & Fabrication**

The pedestal shall be cast aluminum or cast iron.

The pole shaft shall be made of 11-gauge fluted steel with steel anchor plate.

The steel flutes are to be true to pattern, with 16 flutes separated by 16 flat facets.

The luminaire mounting arm shall be aluminum with cast aluminum fittings.

All mounting hardware shall be tamper-resistant, stainless steel.

### **Pole**

The shaft shall have an outside diameter of 7 inches at the anchor plate and taper uniformly to an outside diameter of 5.32 inches (minimum) at the top. The shaft section shall consist of sixteen (16) equally spaced flutes. The outer portion of each flute shall have a flat face, 0.375



( $\pm 1/16$ ) inches in width. The flutes shall remain constant from the top to the bottom of the tapered shaft.

#### **Receptacle**

12A, 120V outlet with weatherproof cover should be mounted 11 feet above grade oriented towards the downstream side of the travel way.

#### **Height**

The height of the post, less tenon, shall be 12 feet.

#### **Tenon**

The top of the post shall be equipped with a tenon to install the luminaire mounting arm. The tenon shall measure 3 inches outside diameter and 12 inches tall.

#### **Grounding Lug**

The post shall be drilled and tapped for a 0.25-inch - # 20 grounding screw, inside the lamp post and opposite the access door.

#### **Handhole**

The decorative pole shall be supplied with at least one (1) handhole/access door at the base. The handhole door shall be secured with tamper-resistant, stainless steel machine screws.

#### **Luminaire Mounting**

The mounting arm shall be a 2-inch pipe with 2.375-inch outside diameter. The mounting arm shall rise 43 inches and measure 48 inches from the post center to luminaire center with a fitting to accept the Silver Spring Pedestrian teardrop style luminaire.

#### **Pedestal**

The pedestal shall measure 18.5 ( $\pm 0.25$ ) inches in diameter with a height of 32 ( $\pm 1.0$ ) inches. The pedestal may be cast as one or two pieces. The castings are to be true to pattern. There shall be no visible signs of separation between the cope and drag sections of the mold. All ornamental components shall be cast aluminum. The pedestal shall have two (2) SILVER SPRING MEDALLIONS (See Standard Drawings for details) mounted at 90 degrees and 270 degrees from the handhole access door.

#### **Bottom Access Hole**

The pedestal shall have a clear opening of 8 inches (minimum) in diameter at grade. The base of the dual, decorative pole shall have an inside diameter sufficient to accommodate two (2) 4-inch diameter, Schedule 40 PVC conduits at the bottom of the post, side by side, for streetlight wiring in accordance with utility company requirements.

#### **Bolt Circle**

The nominal bolt circle of the lamp post shall be 10 inches in diameter and consist of four (4) equally spaced slots to accommodate 1-inch diameter anchor bolts.

#### **Base Plate**

The base plate shall be 1-inch thick and square in shape with rounded corners and a nominal dimension of 10.875 inches per side. The base plate shall be continuously welded to the shaft.



### **Anchor Bolts**

Each pole shall be supplied with four (4) steel anchor bolts. The anchor bolts shall have a diameter of 1 inch, a minimum length of 42 inches plus a 3-inch "L" bend at the bottom and a minimum of 6 inches of thread at the top. Each anchor bolt shall be furnished with two (2) hexagonal nuts and two (2) flat washers for plumbing and securing the pole as necessary.

### **Finish**

The steel and cast aluminum poles, access doors, and hardware shall be finished with a dark green electrostatically applied thermoset polyester powder coat, SAE Standard AMS-STD-595A, Color 14036, Federal Green or approved equal. One (1) pint can of Federal Green touch-up enamel or approved equal, shall be supplied.

### **Pole Information**

The streetlight structure shall be based on King Luminaire model KSSFF-12 C/W KSB77 with arm KA114, or approved equa



## **Decorative Square Steel Pole**

### **Description**

The multi-use, bronze-colored, straight, steel streetlight poles are intended for use along Montgomery County roadways. Any manufacturer, distributor, or vendor who submits a bid shall agree to comply with these specifications and the attached drawings or submit specifications for approval that match these specifications.

Each pole shall be complete with the following:

- a) Base plate with attachment hardware.
- b) Pole top cover with attaching hardware.
- c) J-hook inside of top of pole.
- d) Anchor Bolts, nuts, and washers (as specified).
- e) Handhole and cover plate (as specified).
- f) Typical footing design specifications including but not limited to, base template, anchor dimensions, reinforcement, and footer details.
- g) "National Park Service Brown" finishing.
- h) Attaching horizontal mast arm with hardware suitable to mount rectilinear streetlight and decorative pedestrian streetlight. (See rectilinear luminaire specifications and decorative luminaire specifications).

### **Effective Projected Area (EPA)**

The decorative tall post streetlight pole shall have an EPA allowable for the following assumptions:

- a) Streetlight vehicular luminaire(s) shall be assumed to be rectilinear in shape, minimum length plus width of 36 inches with a side-mounted bracket arm 8 to 12 inches in length.
- b) Decorative pedestrian luminaire shall be assumed to be square in shape, minimum length plus width of 30 inches with a side-mounted bracket arm 9 inches to 12 inches in length.
- c) Up to three (3) streetlight luminaires may be mounted on each pole. Configurations of dual luminaire mounting shall be considered:
  - a. opposite arrangement (180 degrees)
  - b. right angle (90 degrees)
- d) The streetlight luminaire(s) shall be mounted at a height of  $\pm 29$  feet 5 inches above the base. The pedestrian luminaire shall be mounted opposite the rectilinear luminaire (if one is required) at  $\pm 11$  feet 5 inches.
- e) One (1) traffic sign (24 inches x 36 inches max. surface area per sign) may be mounted with the sign's bottom edge 10 feet above the base.

### **Materials & Fabrication**

All casting used to complete the pole shall be clean and smooth, with details well defined and true to pattern.

Steel casting shall conform to ASTM A27, Grade 65-35.



The straight shaft shall be made of a single length of sheet of Manufacturers' Standard Gauge No. 7 (minimum) steel. Poles shall be drilled for electrical wires at the factory, as shown on the attached drawing.

No transverse joints or welds are permitted. The one (1) full longitudinal high frequency resistance weld shall be fusion-welded and ground or cold-rolled smooth.

### **Pole**

Each shaft shall have a 5-inch square cross-section with flat sides and shall have rounded corners (no taper for the length of the pole).

### **Height**

The shaft shall have a length sufficiently long to provide a mounting height of 29 feet 5 inches from the base of the luminaire (nominal length of 30 feet).

### **Handhole**

The pole shall be supplied with two (2) 2.5-inch width (minimum) by 5-inch height (minimum) semi-flush reinforced handholes. One handhole center shall be located 8 to 12 inches above the baseplate. The second handhole center shall be located 11 feet 5 inches above the base plate on the same side of the pole. Each pole shall be equipped with a cover plate for the handhole constructed of a minimum 16-gauge steel cover and retained to the streetlight pole by an eighteen 18-inch long stainless steel chain affixed to both the cover plate and the pole. A 0.5-inch diameter stainless steel grounding lug with nut and flat washer shall be located inside the pole opposite from and centered on the lower handhole.

### **Luminaire Mounting**

Each pole shall be factory drilled for two (2) sets of holes necessary to mount two (2) luminaires as follows:

- a) The streetlight luminaire mounting holes shall be located such that the bottom of the luminaire is 29 feet 5 inches above the base.
- b) The pedestrian luminaire mounting holes shall be located such that the bottom of the mounting bracket arm is 11 feet 5 inches above the base.

The set of factory-drilled mounting holes shall be 90 degrees and 270 degrees to the right (measured clockwise) of the handhole when the pole is viewed from above.

A J-hook shall be welded to the inside of the pole opposite and above the mounting holes for each luminaire.

### **Bottom Access Hole**

The pedestal shall have a clear opening sufficient to accommodate two (2) 4-inch diameter, Schedule 40 PVC conduits at the bottom of the post, side by side, for streetlight wiring in accordance with utility company requirements.

### **Bolt Circle**

The nominal bolt circle shall be 12 inches in diameter.



### **Base Plate**

The base plate shall be a minimum of 1-inch thick steel sufficient to fully develop the ultimate strength of the multi-use pole and shall be secured to the base of the pole-shaft by two (2) circumferentially welds—one on the top of the plate and one on the inside of the base at the bottom of the plate.

Four (4) slotted bolt holds shall have a width of 1.25 inches for 1-inch diameter anchor bolts on a nominal 12-inch bolt circle. The bolt holes shall be slots that can accommodate bolt circles from 10 inches to 12 inches.

### **Anchor Bolts**

Each pole shall be supplied with four (4) steel anchor bolts. The anchor bolts shall have a diameter of 1 inch, a minimum length of 36 inches plus a 4-inch "L" bend at the bottom and a minimum of 6 inches of thread at the top. Each anchor bolt shall be furnished with two (2) hexagonal nuts and two (2) flat washers for plumbing and securing the pole as necessary.

### **Finish**

All visible components shall be finished to produce the appearance of a decorative "Dark Brown" color. One (1) 14-ounce can of touch-up paint matching the color of the streetlight pole shall be furnished for each pole.

### **Tolerances**

These specifications are intended to produce a uniform system of hardware that will minimize the number of stock items that the County or its contractor(s) must maintain. The pole shall be capable of being mounted on the foundation on a decorative cast lamp post (i.e., four (4) 1-inch diameter anchor bolts on a 10- to 12-inch diameter bolt circle).





## **Spun Aluminum Roadway Pole**

### **Description**

The Spun Aluminum Roadway Pole is intended for use along roadways in Montgomery County. Any manufacturer, distributor, or vendor who submits a bid shall agree to comply with these specifications and the attached drawings or submit specifications for approval that match these specifications.

Each pole shall be complete with the following:

- a) Base plate with attachment hardware.
- b) Pole top cover with attaching hardware.
- c) Anchor Bolts, nuts, and washers (as specified).
- d) Handhole and cover plate (as specified).
- e) Typical footing design specifications including but not limited to, base template, anchor dimensions, reinforcement, and footer details.

### **Effective Projected Area (EPA)**

The decorative tall post streetlight pole shall have an EPA allowable for the following assumptions:

- a) Streetlight luminaire shall be assumed to be nearly rectangular in shape, minimum length plus height of less than 34 inches.
- b) The streetlight luminaire shall be mounted at a height of  $\pm 25$  feet above the base.
- c) Up to two (2) traffic signs (24 inches x 36 inches max. surface area per sign) may be mounted with the sign's bottom edge 7 feet above the base.

### **Materials & Fabrication**

The roadway, round, spun aluminum, tapered streetlight poles shall be made of seamless, spun aluminum, tapered shaft.

The tapered shaft and bracket arm shall be fabricated from aluminum tubing.

The bracket mounting plate attachment shall be of a continuous weld design so that it can transfer the full strength of the shaft. The attachment plate shall have a minimum of a two (2) bolt securing system.

### **Pole**

The spun aluminum, tapered streetlight pole shall have a round, circular, cross-section with an outside diameter of 7 inches at the base with a uniform taper decreasing from the base at a rate of 0.1 inch (minimum) to 0.14 inch (maximum) inches per foot of height.

### **Pole Top Cap**

The spun aluminum, tapered streetlight pole shall include a removable pole cap, with a minimum of three (3) set screws, to allow the pole cap to be removed for servicing and maintenance.



### **Height**

The pole shall have a nominal length of 23 feet.

### **Handhole**

The spun aluminum, tapered streetlight pole shall include one (1) peripherally reinforced flush covered handhole located a maximum of 18 inches above the base plate. The handhole shall be located at a 90-degree clockwise angle with respect to the luminaire bracket arm. The handhole shall be a minimum of 3 inches by 5 inches oval.

### **Luminaire Mounting**

The spun aluminum, tapered streetlight pole shall include one simplex arm mount made of cast aluminum for each light arm.

### **Bolt Circle**

The aluminum streetlight pole shall have four (4) 1.25-inch x 2.375-inch slotted holes.

The spun aluminum, tapered streetlight pole shall have a 10-inch bolt circle. Anchor bolts shall not project more than 3 inches from the top of the footer.

### **Base Plate**

The base plate shall be cast aluminum and shall be attached to the tapered shaft with a continuous circumferential weld. The base plate shall be a 11.1875-inch square with rounded corners.

Each pole shall include four (4) cast aluminum bolt covers and four (4) stainless steel, self-tapping, hex head screws, to secure the bolt covers to pre-drilled holes in the base plate.

### **Anchor Bolts**

Each pole shall be supplied with four (4) steel anchor bolts. The anchor bolts shall have a diameter of 1 inch, a minimum length of 36 inches plus a 4-inch "L" bend at the bottom and a minimum of 6 inches of thread at the top. Each anchor bolt shall be furnished with two (2) hexagonal nuts and four (4) flat washers for plumbing and securing the pole as necessary.

### **Finish**

The spun aluminum, tapered streetlight pole shall have a sanded natural aluminum "satin" ground finish, or as specified.

### **Pole Information**

The streetlight structure shall be based on Valmont model 230045705T4B with 1MA0630S45 or 2MA0630S45 for the lighting arm(s) and simplex fitting(s), or approved equal.



## **40' Square Steel Pole**

### **Description**

The 40-foot square steel pole is intended for use along Montgomery County roadways. Any manufacturer, distributor, or vendor who submits a bid shall agree to comply with these specifications and the attached drawings or submit specifications for approval that match these specifications.

Each pole shall be complete with the following:

- a) Base plate with attachment hardware.
- b) Pole top cover with attaching hardware.
- c) J-hook inside of top of pole.
- d) Anchor Bolts, nuts, and washers (as specified).
- e) Handhole and cover plate (as specified).
- f) Typical footing design specifications including but not limited to, base template, anchor dimensions, reinforcement, and footer details.
- g) One (1) 14-ounce spray paint matching the finishing color.

### **Effective Projected Area (EPA)**

The decorative tall post streetlight pole shall have an EPA allowable for the following assumptions:

- a) Streetlight luminaires shall be assumed to be rectilinear in shape, minimum length plus width of 36 inches with a side-mounted bracket arm 8 to 12 inches in length.
- b) One or two streetlight luminaires may be mounted on each tall-post streetlight pole. Two configurations of dual luminaire mounting shall be considered:
  - a. opposite arrangement (180 degrees)
  - b. right angle (90 degrees)
- c) The streetlight luminaires shall be mounted at a nominal mounting height of 39 feet 5 inches above the base.
- d) One (1) traffic sign (24 inches x 36 inches max. surface area per sign) may be mounted with the sign's bottom edge 7 feet above the base.

### **Materials & Fabrication**

The shaft shall be made of a single length of sheet of Manufacturers' Standard Gauge No. 11 (minimum) steel. All castings used to complete the pole shall be clean and smooth with details well defined and true to pattern.

No transverse joints or welds are permitted. The one (1) longitudinal weld shall be fusion-welded and ground or cold-rolled smooth. The curvature (for straightness) shall not exceed 0.5 inch in any 10-foot portion of the total length.

### **Pole**

Each shaft shall have a square cross-section of 8 ( $\pm 0.5$ ) inches on each side, and with a uniform taper decreasing from the base at a rate of 0.1 inch (minimum) to 0.14 inches maximum per foot of height.



### **Height**

The shaft shall have a length sufficiently long to provide a mounting height of 40 feet for the base of the luminaire (nominal length of 40 feet).

### **Tenon**

When required, the tenon shall measure 2.375 inches in outside diameter.

### **Handhole**

The tall-post streetlight pole shall be supplied with a 4-inch wide by 8-inch high semi-flush reinforced handhole opening located a minimum of 8 inches above the baseplate. Each pole shall be equipped with a cover plate for the handhole constructed of a minimum 11-gauge steel, to be attached to the streetlight pole with two (2) tamper-proof screws and retained to the streetlight pole by an 18-inch long stainless steel chain affixed to both the cover plate and the tall-post streetlight pole.

### **Luminaire Mounting**

Each pole shall be factory-drilled for one set of holes necessary to mount the luminaire so that the bottom of the luminaire is 39 feet above the base. The set of factory-drilled mounting holes shall be 90 degrees counterclockwise angle from the handhole when viewed from above.

A J-hook shall be welded to the inside of the streetlight pole opposite to and above the mounting holes for the luminaire.

### **Bottom Access Hole**

The base of the streetlight pole shall have an inside diameter sufficient to accommodate two (2) 4-inch diameter, Schedule 40 PVC conduits at the bottom of the post, side by side, for streetlight wiring in accordance with utility company requirements.

### **Base Plate**

A minimum 1-inch thick steel base plate sufficient to fully develop the ultimate strength of the tall-post streetlight pole shall be secured to the base of the pole-shaft with two (2) self-closing transverse welds at the following locations:

- on the inside of the base at the bottom of the pole-shaft
- at the top of the baseplate

The base shall telescope into the pole-shaft. The baseplate may either be circular in shape with rounded corners and a nominal dimension of 15 inches or square in shape with rounded corners and a nominal dimension of 15 inches per side.

### **Bolt Circle**

The nominal bolt circle of the post shall be 13.5 inches in diameter and consist of four (4) equally spaced slots. Each slot shall have a width of 1.25 inches to accommodate a 1-inch diameter anchor bolt. The slots shall be able to accommodate bolt circles from 13 to 14 inches.

### **Anchor Bolts**

Each pole shall be supplied with four (4) steel anchor bolts. The anchor bolts shall have a diameter of 1 inch, a minimum length of 36 inches plus a 4-inch "L" bend at the bottom and a



minimum of 6 inches of thread at the top. Each anchor bolt shall be furnished with two (2) hexagonal nuts and one (1) flat washer for plumbing and securing the pole as necessary.

**Finish**

All visible components shall then be finished to produce the appearance of a decorative “National Park Service Brown” color.

**Tolerances**

These specifications are intended to produce a uniform system of hardware that will minimize the number of stock items that the County or its contractor(s) must maintain. The pole shall be capable of being mounted on the foundation with or without a break-away transformer base.



## **Decorative Wheaton Pedestrian Post**

### **Description**

These streetlight poles are intended for use in medians and on main streets, in urban streetscape areas. Any manufacturer, distributor, or vendor who submits a bid shall agree to comply with these specifications and the attached drawings.

Each pole shall be complete with the following:

- a) Base plate and cover with attachment hardware.
- b) Anchor Bolts, nuts, and washers (as specified).
- c) Typical footing design specifications including but not limited to, base template, anchor dimensions, reinforcement and footer details.
- d) One (1) pint of touch-up paint to match the finishing color.

### **Effective Projected Area (EPA)**

The decorative tall post streetlight pole shall have an EPA allowable for the following assumptions:

- a) Pedestrian luminaires shall be assumed to be spherical in shape, minimum length plus width of 36 inches.
- b) The pedestrian luminaire shall be mounted at a nominal mounting height of 11 feet above the base.
- c) Up to two (2) traffic signs (24 inches x 36 inches max. surface area per sign) may be mounted with the sign's bottom edge 7 feet above the base.

### **Materials & Fabrication**

The shaft shall be made of a single length of sheet of Manufacturers' Standard Gauge No. 7 (minimum) steel.

The pole shall be secured to a steel plate base plate by means of two continuous circumferential welds and shall develop the full strength of the adjacent shaft section to resist bending action.

### **Pole**

The cross section shall form eight (8) equally spaced doric flutes with the radius of the crest not to exceed the thickness of the material. The pedestal pole shall have a base diameter of 6.5 inches across flutes with a uniform continuous taper decreasing from the base of 0.14 inch per foot of height.

### **Pole Cap**

The pedestal pole shall be capped with a 0.375-inch thick steel plate. The cap shall incorporate a 4-inch tenon to allow for the luminaire to be placed on top.

### **Height**

The height of the pedestal pole shall be 11 feet.



### **Handhole**

The pedestrian pole shall have a raised 3-inch wide by 5-inch high handhole with its bottom edge located 8 inches above the bottom of the base plate. A handhole cover shall be provided for each pole and shall fit flush with the hand hole frame. The handhole shall be fastened with captive fasteners. The handhole cover shall be retained by a stainless steel chain affixed to the inside of the pole. Any screws or bolts shall have the same screw heads as the cover base retaining screws.

### **Bolt Circle**

The bolt circle diameter shall be 9.5 inches.

### **Base Plate**

All base plates are to be square in shape with rounded corners. Four (4) bolt holes are to have radial slots to accommodate 1-inch diameter bolts for pedestal pole. The base plate thickness shall be 1 inch. The nominal square shall be 9.5 inches.

Each pole there shall be supplied with a wraparound cover conforming to the shape of the fluted pole. This cover shall be fabricated from Manufacturers' Standard Gauge No. 16 (minimum) steel and shall completely cover the base and anchor bolt nuts. The height shall be no more than 4 inches, and the cover shall be painted to match the color of the poles. The covers will be manufactured in two halves and shall be joined together in the field with the use of #8 32 x 0.5-inch stainless steel self-tapping screws, with Allen head. One (1) Allen wrench shall be supplied for every 20 poles or partial score of poles. Provisions shall be made at each corner for a weep opening for drainage. The cover shall be no larger than 10.75 inches for the pedestrian pole.

### **Anchor Bolts**

Each pole shall be supplied with four (4) steel anchor bolts. The anchor bolts shall have a diameter of 1 inch, a minimum length of 15 inches plus a 4-inch "L" bend at the bottom and a minimum of 6 inches of thread at the top. Each anchor bolt shall be furnished with two (2) hexagonal nuts and one (1) flat washer for plumbing and securing the pole as necessary.

### **Finish**

All visible components shall then be finished to be SAE AMS-STD-595A, Color 27040, "Semi-Gloss Black" in color.

### **Pole Information**

#### Interior Surfaces

All interior surfaces of the poles, cover bases, pole tops and hand hole covers shall be painted with a red lead oil paint for a suitable alternate after the exterior finish has been applied.



## **Decorative Wheaton Vehicular Pole**

### **Description**

The tapered fluted davit vehicular streetlight poles are intended for use in medians and on main streets, in urban streetscape areas. Any manufacturer, distributor, or vendor who submits a bid shall agree to comply with these specifications and the attached drawings or submit specifications for approval that match these specifications.

Each pole shall be complete with the following:

- a) Base plate and cover with attachment hardware.
- b) Anchor Bolts, nuts, and washers (as specified).
- c) Typical footing design specifications including but not limited to, base template, anchor dimensions, reinforcement, and footer details.
- d) One (1) pint of touch-up paint, SAE Standard AMS-STD-595A, Color 14036, Federal Green.

### **Effective Projected Area (EPA)**

The decorative tall post streetlight pole shall have an EPA allowable for the following assumptions:

- a) Streetlight luminaires shall be assumed to be spherical in shape, minimum length plus width of 48 inches.
- b) The streetlight luminaire shall be mounted at a nominal mounting height of  $\pm 25$  feet above the base.
- c) Up to two (2) traffic signs (24 inches x 36 inches max. surface area per sign) may be mounted with the sign's bottom edge 7 feet above the base.

### **Materials & Fabrication**

The pole shall consist of a shaft fabricated from cold-rolled steel having a thickness of Manufacturers' Standard Gauge No. 7 (minimum) steel. It shall be of one piece construction with one longitudinal weld which shall be rolled smooth. The pole shall be secured to a steel plate base by means of two continuous circumferential welds and shall develop the full strength of the adjacent shaft section to resist bending action.

### **Pole**

The cross section shall form eight (8) equally spaced doric flutes with the radius of the crest not to exceed the thickness of the material. The davit pole shall have a base diameter of 8 inches across flutes. The davit pole shall have a uniform continuous decreasing taper from the base of 0.14 inch per foot of pole height.

Davit pole shall have 1.75-inch blind half coupling welded in pole with plugs. Plugs shall be threaded with Allen head recess, which shall fit flush with the surface of the pole. This type threaded coupling to be welded on both sides of the pole to mount straight arms at 15 feet above base.





### **Receptacle**

Each davit pole shall be supplied with a 3-wire weathertight receptacle (Festoon outlet). The electrical receptacle shall be mounted 16 feet above the base and shall be opposite the lighting arm.

### **Height**

The height of the davit pole shall be 30 feet.

### **Tenon**

The davit pole shall have a tenon with an outside diameter of 2.375 inches and a length of 3 inches.

### **Handhole**

The davit pole shall have a raised 4-inch wide by 6.5-inch high handhole with its bottom edge located 8 inches above the bottom of the base plate. A handhole cover shall be provided for each pole and shall fit flush with the hand hole frame. The handhole shall be fastened with captive fasteners. The handhole shall be parallel with the davit arm and 90 degrees past the davit arm when the pole is observed from above. The handhole cover shall be retained by a stainless steel chain affixed to the inside of the pole. Any screws or bolts shall have the same screw heads as the cover base retaining screws.

### **Luminaire Mounting**

Luminaire shall have a 2-inch slip fit and shall have a max weight of 75 pounds.

### **Bolt Circle**

The bolt circle shall have a diameter of 11 inches.

### **Base Plate**

All base plates shall be square in shape with rounded corners. Four (4) bolt holes shall have radial slots to accommodate 1.25-inch diameter anchor bolts. The base plate thickness shall be 1 inch. The nominal square shall be 9.5 inches.

Each pole there shall be supplied with a wraparound cover conforming to the shape of the fluted pole. This cover shall be fabricated from Manufacturers' Standard Gauge No. 16 (minimum) steel and shall completely cover the base and anchor bolt nuts. The height shall be no more than 4 inches, and the cover shall be painted to match the color of the poles. The covers will be manufactured in two halves and shall be joined together in the field with the use of #8 32 x 0.5-inch stainless steel self-tapping screws, with Allen head. One (1) Allen wrench shall be supplied for every 20 poles or partial score of poles. Provisions shall be made at each corner for a weep opening for drainage. The cover shall be no larger than 12.5 inches for the davit pole.

### **Anchor Bolts**

Each pole shall be supplied with four (4) steel anchor bolts. The anchor bolts shall have a diameter of 1.25 inches, a minimum length of 48 inches plus a 4-inch "L" bend at the bottom and a minimum of 6 inches of thread at the top. Each anchor bolt shall be furnished with two (2) hexagonal nuts and one (1) flat washer for plumbing and securing the pole as necessary.



### **Finish**

All visible components shall then be finished to produce the appearance of a decorative "Semi-Gloss Black" Federal Standard 595B color 27040.

One (1) 14-ounce spray can, to match the color of the streetlight, shall be supplied for each streetlight pole.

### **Pole Information**

#### Interior Surfaces

All interior surfaces of the poles, cover bases, pole tops and hand hole covers shall be painted with a red lead oil paint for a suitable alternate after the exterior finish has been applied.



## **Transformer Base (Breakaway)**

### **Description**

This breakaway, bronze-colored, transformer base for a streetlight pole specification is intended for use along Sam Eig Highway only. Any manufacturer, distributor, or vendor who submits a bid shall agree to comply with these specifications and the attached drawings.

### **Materials & Fabrication**

All casting used to complete the transformer base shall be clean and smooth with details well defined and true to pattern.

### **Handhole**

The transformer base shall be supplied with one handhole cover door with a minimum width of 7 inches and a minimum height of 8 inches. The opening shall be placed 90 degrees clockwise from the luminaire when viewed from above. Each handhole cover door shall be attached to the transformer base by an 18-inch long stainless steel chain affixed to both the cover plate and the transformer base.

### **Bolts**

Each base shall be supplied with four (4) galvanized bolts. The hex-head bolts shall have a diameter of 1 inch. Each hex-head bolt shall be furnished with one (1) hexagonal nut and one (1) flat washer for securing the pole as necessary.

### **Finish**

The contact area between the transformer base and concrete foundation shall be shop-coated with coal tar epoxy bitumastic 300 M. or equal meeting SSPC-Paint 16 specifications. The thickness of the coating shall be 6 to 8 mils. The coating shall be completely dry before installation. The top of the foundation shall not be painted.

All visible components shall then be finished to produce the appearance of a decorative "National Park Service Brown" color.

One (1) 14-ounce spray can, to match the color of the transformer base, shall be provided with each transformer base supplied.

### **Tolerances**

These specifications are intended to produce a uniform system of hardware, which will minimize the number of stock items that the County or its contractors must maintain.



## Fixtures and Luminaires

All LED luminaires to be used under this contract shall meet the following requirements. In case of conflict, these requirements supersede those specified under various luminaire types, unless otherwise approved by the Engineer in writing.

### General Requirements

1. Shall maintain UV protection and rust resistance.
2. Flat tempered glass or polycarbonate lens cover, unless specifically specified.
3. Bird/pest guard for arm area for cobrahead fixtures.
4. Landfill accepted (RoHS compliant).
5. Shall be equipped with 3-prong NEMA twist-lock photocell.
6. Luminaire housing and structural parts shall be of A360 Cast Aluminum Alloy.

All luminaires shall meet the requirements of American Association of State Highway and Transportation Officials (AASHTO) Standard, "Specification for Structural supports for Highway Signs, Luminaires and Traffic Signals," latest edition.

### Technical Requirements

Nominal luminaire input voltage	120 V
Minimum % of initial output at 36,000 hours operation	90%
Minimum Luminaire Warranty	10 years
Rated Correlated Color Temperature (CCT)	3000° K Context-sensitive locations may use as low as 2700° K or as high as 3500° K
Maximum nominal Backlight-Uplight-Glare (BUG) rating	B1-U2-G1
Maximum effective projected area	0.7 SF
Typical minimum ambient temperature during operation	-22 °C
Typical maximum ambient temperature during operation	42 °C
Minimum rating for housing	IP70
Driver rating	550mA or less (90% power factor or better)
Color Rendering Index (CRI)	70
Lumen maintenance @ 25° C & 80,000 hours	>L70
UL Compliance	8750 & 1598

### Manufacturer Deliverables

1. LM-79 testing data for the complete LED luminaire.



2. LM-80 testing data for LED light source.
3. 10-year warranty period
4. 100% made in America.
5. PDF copies of ISO plots.
6. Tested input wattage of the LED luminaire.



## **Cobrahead (Roadway)**

### **Purpose**

The purpose of these specifications is to provide minimum requirements for the design, manufacture, fabrication, finishing and delivery of a roadway, LED optics (flat glass) style luminaire with Type III distribution shall be made of low copper die-cast aluminum housing. The roadway, LED, style luminaire is intended for use along roadways in Montgomery County. Any manufacturer, distributor or vendor who submits a bid shall agree to comply with these specifications and the attached drawings.

### **Description**

Each streetlight luminaire includes the following:

- a. Die-cast aluminum housing and drop style door.
- b. 120 volt LED Driver.
- c. LED Optical Assembly (Type III distribution).
- d. NEMA 7-pin twist-lock multi-volt standard photocell.
- e. All necessary hardware required for mounting on bracket arm, as specified.

### **Shape and Minimum Size**

- a. The luminaire shall be of a rounded rectangular shape. The actual size may vary depending on the specified wattage.
- b. The luminaire shall be suitable to accommodate several LED Optical Assembly (Type III distribution) and associated LED driver.

### **Finish**

The luminaire shall have a gray polyester powder coat finish. During the finishing process, all critical openings shall be plugged to prevent contamination of the threads or reduction of other critical openings.

### **Housing**

The luminaire shall consist of a watertight housing fabricated from low copper die-cast aluminum housing, with die-cast aluminum drop-style doors. The drop-style doors shall be hinged on one side and secured on the opposite side with a captive stainless steel latch or captive stainless steel screw. All castings used to fabricate the luminaire housing shall be clean and smooth, with details defined and true to pattern. The housing shall be suitable to accommodate the LED Optical Assembly and LED driver.

### **Driver & Surge Protection**

The driver shall be mounted to facilitate easy removal for maintenance operations and replacement. The driver shall be equipped with a 10KV Surge Protection and suppression system. All electrical connections shall be polarized and of plug-in design. The driver shall be wired to receive 120 volt AC current. The driver shall reliably start and operate the lamp in ambient temperatures down to minus 30 degrees. The terminal block shall be capable of accepting up to a #6 AWG wire.



**Cooling System**

The luminaire shall consist of a heat sink with no fans, pumps, or liquids, and shall have wide angular fin in design to be resistant debris buildup that may degrade thermal dissipation performance.

**Photocell**

The luminaire photocell receptacle shall be mounted on the die-cast aluminum housing. The photocell shall be ANSI C136.41 7-pin.

**Optical System**

The luminaire shall contain a precision designed injection molded acrylic optic plate and LED chamber, with a type III distribution pattern. The lens should be an impact resistant tempered glass.

**Mounting Bracket Arm**

The luminaire shall be able to be mounted on bracket arms with 1.25- or 2-inch slipfitter tenons. This may include two (2) or four (4) bolt slipfitter bracket assemblies with vertical tilt adjustment range of  $\pm 5\%$ . The mounting bracket area shall be protected with a bird-guard type gasket.

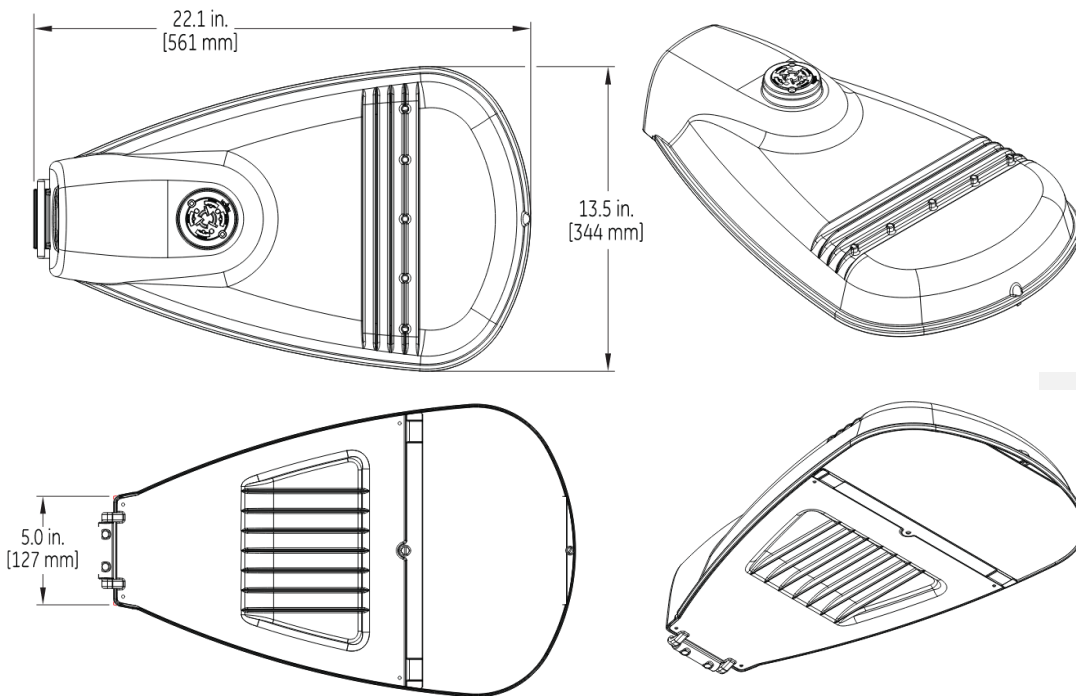

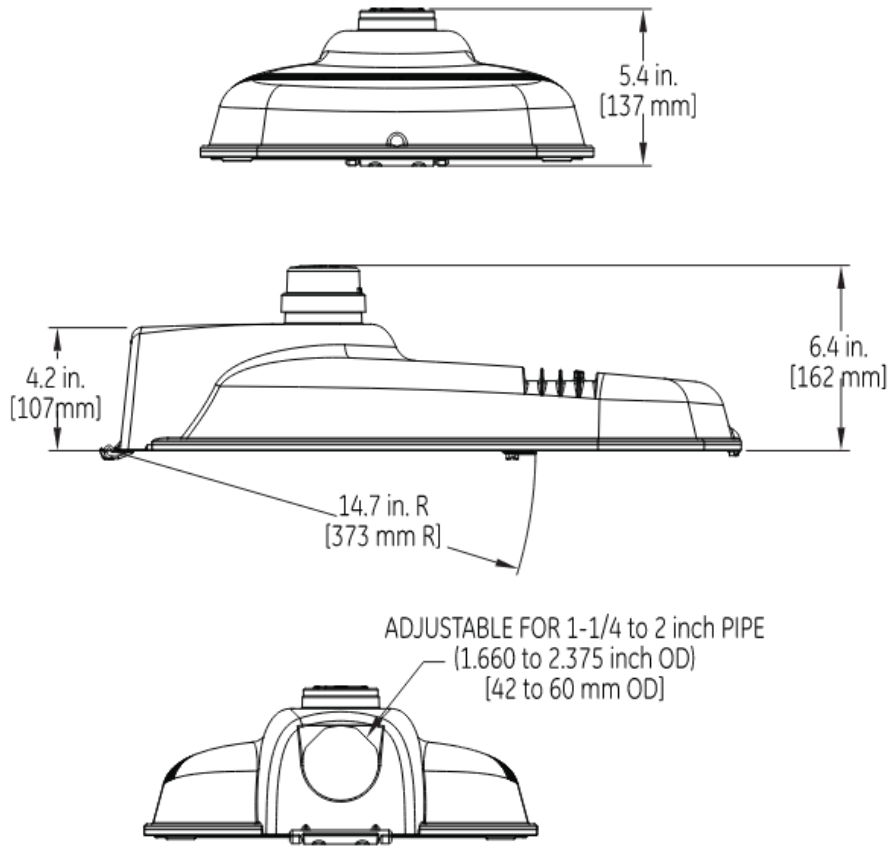





## **Bethesda Globe**

### **Purpose**

The purpose of these specifications is to prescribe the minimum requirements for the design, manufacture, fabrication, finishing and delivery of Bethesda LED Globe luminaire. The Bethesda Globe luminaires are intended for use in urban streetscape areas. Any manufacturer, distributor or vendor who submits a bid shall agree to comply with these specifications and attached drawings.

### **Description**

This luminaire shall be an outdoor decorative post top fixture, cylindrical in shape with an overall height of 42 ( $\pm 1$ ) inches and a maximum width of 19 ( $\pm 0.5$ ) inches at top (see attached drawings). All exterior and structural parts shall be cast of aluminum alloy. Exterior castings shall be cast in two pieces, have a smooth surface finish, and be free of mold lines. All components shall fit together snugly so as to provide weather-proof joints in the luminaire top. All visible metal components shall have raised surface decorations or ribs, as shown on the attached drawings, which are molded integrally with the base piece. Likewise, the hinges between the top and main body as well as between the driver cover and the base shall be cast integrally with the piece or bolted through the base piece. All metal parts shall be corrosion-proof. The luminaire shall come ready for quick and easy field assembly or fully assembled and shall include the following components:

- a. Lamp
- b. Twist-Lock type photoelectric cell installed on the ballast cover.
- c. 120 Volt Driver with 10KV surge protection.
- d. All necessary hardware and fasteners to assemble and secure on a 2.875-inch nominal diameter cast iron or aluminum tenon.
- e. The luminaire must be able to accommodate a 120 volt drive and surge protector.

### **Lens**

The lens shall consist of seamless flat glass, not subject to deterioration by natural light. The lens shall have a continuous neoprene waterproof gasket at top. The gaskets shall fit into grooves molded into the top or over retaining rings molded inside the top plate.

### **Metal Cage**

The metal cage shall be constructed of diecast A360 aluminum alloy. The metal cage shall have 4 legs each with a square decorative block with solid rectangular band around the top of the cage between each decorative block. The support columns shall consist of four (4) dual columns connecting the top and bottom of the fixture.

### **Hinged Luminaire Top & Optical System**

The hinged luminaire top shall consist of an LED optic assembly and all exterior components visible in plain view above the lens. The optical system shall be located in the top cover of the fixture. A gasket between the cover and the ring along with a flat glass plate and gasket beneath the LED panel and create a sealed optical compartment that will meet IP rating. The top must have an attached, removable brace to support the top when open. The optical system shall provide an IES asymmetric or symmetric full cut off distribution.



### **Electrical Module**

The electrical components shall be mounted on a steel plate that is removable without use of tools. All components shall be plug-in. The housing door shall be hinged and be latched to provide east access to the electrical module. The housing door shall be fastened by a captive fastener.

### **Driver and Surge Protector**

The driver shall be mounted to facilitate easy removal for maintenance operations. The driver shall be equipped with a 10kV Surge Protection and suppression system. All electrical connections shall be polarized and of plug-in design. The driver shall be wired to receive 120 volt AC current. The driver shall reliably start and operate the lamp in ambient temperatures down to minus 30 degrees. The terminal block shall be capable of accepting up to a #6 AWG wire.

### **Photocell**

The photocell shall be a twist-lock and shall be mounted inside the fixture.

### **Underwriters Laboratory Listing**

The entire luminaire assembly shall be U.L. listed and suitable for wet locations.

### **Exterior Finish**

The exterior finish shall be SAE AMS-STD-595A, Color 14036, Federal Green or Tiger Drylac #RAL6009 electrostatically applied thermoset polyester powder coat.



## **Colonial Post Top**

### **Purpose**

The purpose of these specifications is to prescribe the minimum requirements for the design, manufacture, fabrication, finishing and delivery of colonial post-top, LED optics, type III distribution, style luminaire. This luminaire is intended for use on or with the lack fiberglass pole. These colonial post-tops, LED optics, type III distribution, style luminaires are intended for use along residential roadways, walkways, and tunnels throughout Montgomery County. Any manufacturer, distributor or vendor who submits a bid shall agree to comply with these specifications and attached drawings.

### **Description**

The residential, colonial post-top, LED optics, type III distribution, style luminaire is made of a cast aluminum alloy housing. Each streetlight luminaire shall include the following:

- a. Cast aluminum housing and hinged top canopy.
- b. 120 volt LED Driver.
- c. 10KV Surge Suppression Device built in.
- d. NEMA standard photoelectric control receptacle and NEMA multi-volt standard photocell.
- e. Acrylic or Polycarbonate resin refractor side panels (lens).
- f. All necessary hardware required for mounting on fiberglass poles, as specified.

### **Design**

The luminaire shall be of a trapezoidal shape. The minimum size for the luminaire shall 40.0 inches (sum of the length plus height), when viewed from the side.

The luminaire shall be suitable to accommodate 120 volt LED Driver, 10KV Surge Suppression Device and NEMA standard photoelectric control receptacle and NEMA multi-volt standard photocell.

### **Effective Projected Area (EPA)**

The luminaire shall have a maximum estimated allowable EPA for the luminaire of 0.7 ± square feet.

### **Finish**

The luminaire shall have a black polyester powder coat finish. During the finishing process, all critical openings shall be plugged to prevent contamination of the threads or reduction of other critical openings.

### **Housing**

The luminaire shall consist of a watertight housing fabricated from die-cast aluminum with a gasketed die-cast aluminum canopy. The canopy shall be hinged on one side and secured on the opposite side with a captive stainless steel screw. All castings used to fabricate the luminaire housing shall be clean and smooth with details defined and true to pattern. The housing shall be suitable to accommodate 120 volt LED Driver, 10kV Surge Suppression Device and NEMA standard photoelectric control receptacle and NEMA multi-volt standard photocell.



**Driver & Surge Protection**

The driver shall be mounted to facilitate easy removal for maintenance operations. The driver shall be equipped with a 10KV Surge Protection and suppression system. All electrical connections shall be polarized and of plug-in design. The driver shall be wired to receive 120 volt AC current. The driver shall reliably start and operate the lamp in ambient temperatures down to minus 30 degrees. The terminal block shall be capable of accepting up to a #6 AWG wire.

**Photocell**

The photocell receptacle shall be mounted for easy access and maintenance. The photocell shall be of the NEMA twist-lock type.

**Side refractor panels**

The luminaire shall be equipped with acrylic or polycarbonate resin refractor panels, with spring loaded retainer clips to hold refractor panels.

**Slip Fitter**

The slip fitter shall have a nominal inside diameter of 3.375 ( $\pm 0.25$ ) inches and shall be secured to the lamp post tenon with three or four evenly spaced set screws. The slip fitter shall accommodate a tenon 3.0 inches long.

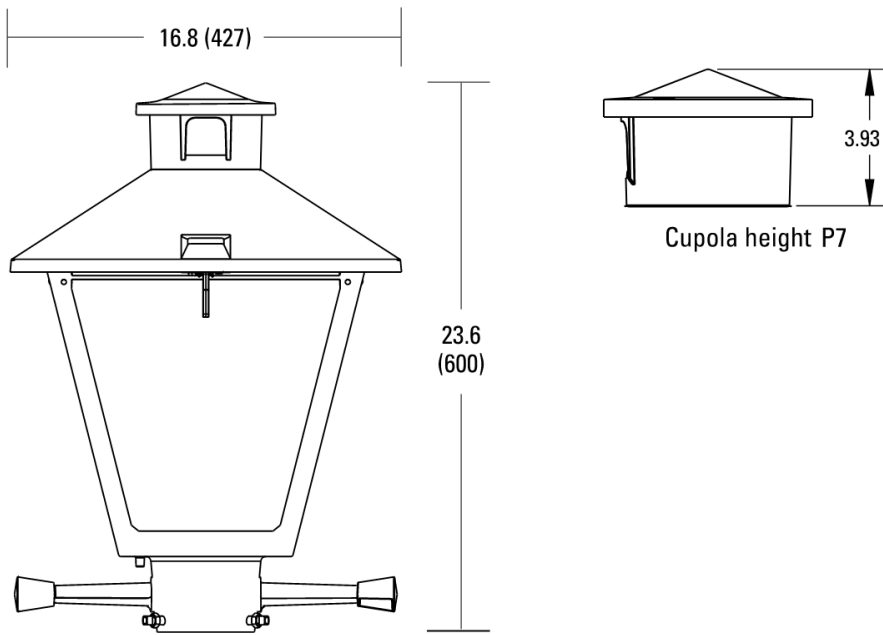



## **Washington Globe**

### **Purpose**

The purpose of these specifications is to provide minimum requirements for the design, manufacture, finishing and delivery of the Washington Globe (hard top) LED luminaire. The Washington Globe is intended to be mounted on decorative pole as specified along roadways throughout Montgomery County. Any manufacturer, distributor, or vendor who submits bid shall agree with these specifications.

### **Description**

The luminaire shall be an outdoor decorative post top fixture, cylindrical in shape with an overall height between 42.5 ( $\pm 2.0$ ) inches and a overall width between 16.5 ( $\pm 0.5$ ) inches for the globe (see attached drawing). All exterior and structural parts shall consist of aluminum alloy or cast iron. Exterior castings shall be cast in one piece having a smooth surface finish and free of mold lines. A separate cover for a ballast drawer/tray is permitted if the ballast drawer cover is secured to the luminaire body with captive fasteners. All components shall fit together snugly and shall be fitted with continuous neoprene gaskets so as to weatherproof joints between metal interfaces. Visible metal surfaces shall have raised decorations integrally molded in the base piece. All metal parts shall be corrosion resistant. The luminaire shall come ready for quick an easy field assembly or fully assembled:

- a. LED Optical Assembly (Type III distribution).
- b. 120 volt LED Driver.
- c. Button type photocell installed on the metal body of the luminaire or ballast tray cover.
- d. All necessary hardware and fasteners to assemble and secure on post tenon.

### **Globe**

The globe should be supplied as two pieces, chemically matching material as a unit and permanently sealed together with a chemical bonding process. The globe bottom shall be alabaster rippled and made of UV stabilized acrylic. The globe roof shall be of a spun aluminum design. The roof and bottom globe sections are secured in a slip-fit, 0.5" overlap design and provide a mechanical lock and enabling easy future replacement of either the roof or bottom globe section if required. The roof finish shall be polyester thermoset powdercoat. The globe shall be of a traditional "Washington Globe" (acorn) shape designed to achieve the photometric performance specified by Illumination Engineering Society (IES).

The bottom surface of the globe shall interface closely with the metal body of the fixture so as to provide a weather, dust, and insect proof interface. The globe or its mounting ring shall be fastened with three or more recessed set screws to the body of the fixture.

### **Driver And Surge Protector**

The driver shall be mounted to facilitate easy removal for maintenance operations. The driver shall be equipped with a 10kV Surge Protection and suppression system. All electrical connections shall be polarized and of plug-in design. The driver shall be wired to receive 120 volt AC current. The driver shall reliably start and operate the lamp in ambient temperatures down to minus 30 degrees. The terminal block shall be capable of accepting up to a #6 AWG wire.



**Photocell**

The photocell shall be a twist-lock type or equal, mounted on the metal body of the luminaire or the cover of the ballast tray drawer.

**Metal Body**

The body shall be cast in one piece and shall have raised surface decorations. The body shall taper smoothly between the slip fitter to the base of the globe. The body shall be constructed with weep holes or channels to prevent rainwater from collecting at the top of the body.

**Slip Fitter**

The slip fitter shall have a nominal inside diameter of 3.375 inches (±0.25) and shall be secured to the lamp post tenon with three of four evenly spaced set screws. The slip fitter shall accommodate a tenon 3.0 inches long.

**Finial**

The finial shall be made of cast aluminum, and securely fastened to the top of the globe.

**Finish**

The exterior surface of the finial and luminaire body shall be factory finished with a dark green electrostatically applied polyester powder coat. The color shall be SAE AMS-STD-595A, Color 14036, Federal Green.

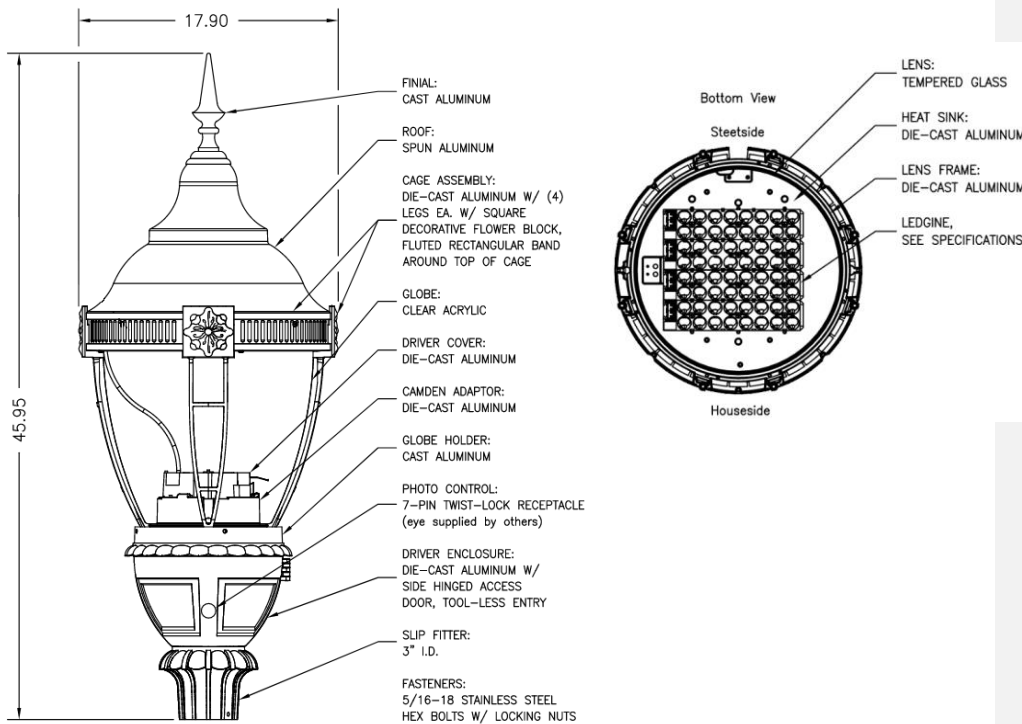



## **Damascus Pedestrian**

### **Purpose**

The purpose of these specifications is to prescribe the minimum requirements for the design, manufacture, fabrication, finishing and delivery of Damascus pedestrian luminaire. This luminaire is intended for use in the urban streetscaped areas. Any manufacturer, distributor or vendor who submits a bid shall agree to comply with these specifications and attached drawings.

### **Luminaire**

The luminaire shall consist of a 413F, Low-Copper cast aluminum 0.090" thick spun aluminum. It shall be easy to access the lamp, and the hinged lens frame should be a cast aluminum with stainless steel spring latch for tool-less lamp access. This luminaire should also have a weatherproof ballast assembly that isolates the ballast from water and heat for longer life. All of the fasteners should be non-ferrous to prevent corrosion and ensure longer life. The entire fixture should be UL listed to U.S. Safety standards for wet location. This fixture should be manufactured to ISO 9001:2000 Standards. The entire assembly shall be U.L. or C.S.A. listed suitable for wet location.

### **LED Optical Assemble**

The optical assembly shall consist of an injection molded acrylic optical plate with Type III distribution. The lens shall be clear tempered flat glass.

### **Driver & Surge Protection**

The driver shall be mounted to facilitate easy removal for maintenance operations. The driver shall be equipped with a 10KV Surge Protection and suppression system. All electrical connections shall be polarized and of plug-in design. The driver shall be wired to receive 120 volt AC current. The driver shall reliably start and operate the lamp in ambient temperatures down to minus 30 degrees. The terminal block shall be capable of accepting up to a #6 AWG wire.

### **Exterior Finish**

The exterior of the luminaire shall be finished in a hunter green custom color. The finish of the luminaire shall be Thermoset polyester powdercoat that is electrostatically applied after a five-stage conversion cleaning process and bonded by heat fusion thermosetting. This finish should be laboratory tested for superior weatherability and fade resistance in accordance with ASTM B-117-64 and NSI/ASTM G53-77 specifications.



## **Damascus Vehicular**

### **Purpose**

The purpose of these specifications is to provide minimum requirements for the design, manufacture, fabrication, finishing and delivery of a Damascus LED Vehicular style luminaire distribution shall be made of low copper die-cast aluminum housing. The Damascus LED Vehicular style luminaire is intended for use along roadways in Montgomery County. Any manufacturer, distributor or vendor who submits a bid shall agree to comply with these specifications and the attached drawings.

### **Description**

Each streetlight luminaire includes the following:

- a. Die-cast aluminum housing and drop style door.
- b. 120 volt LED Driver.
- c. LED Optical Assembly (Type III distribution).
- d. NEMA 3-prong twist-lock standard photoelectric control receptacle on the top of the luminaire.
- e. NEMA 3-prong twist-lock multi-volt standard photocell.
- f. All necessary hardware required for mounting on bracket arm, as specified.

### **Shape and Minimum Size**

- a. The luminaire shall be of a rounded rectangular shape. The actual size may vary depending on the specified wattage.
- b. The luminaire shall be suitable to accommodate several LED Optical Assembly (Type III distribution) and associated LED driver.

### **Effective Projected Area (EPA)**

The luminaire shall have a maximum estimated allowable EPA for luminaire of 0.7 SF.

### **Finish**

The luminaire shall have a federal Brown polyester powder coat finish. During the finishing process, all critical openings shall be plugged to prevent contamination of the threads or reduction of other critical openings.

### **Housing**

The luminaire shall consist of a watertight housing fabricated from low copper die-cast aluminum housing, with die-cast aluminum drop-style doors. The drop-style doors shall be hinged on one side and secured on the opposite side with a captive stainless steel latch or captive stainless steel screw. All castings used to fabricate the luminaire housing shall be clean and smooth, with details defined and true to pattern. The housing shall be suitable to accommodate the LED Optical Assembly and LED driver.

### **Driver & Surge Protection**

The driver shall be mounted to facilitate easy removal for maintenance operations. The driver shall be equipped with a 10kV Surge Protection and suppression system. All electrical connections shall be polarized and of plug-in design. The driver shall be wired to receive 120 volt AC current. The driver shall reliably start and operate the lamp in ambient temperatures





down to minus 30 degrees. The terminal block shall be capable of accepting up to a #6 AWG wire.

#### **Cooling System**

The luminaire shall consist of a heat sink with no fans, pumps, or liquids, and shall have wide angular fin in design to be resistant debris buildup that may degrade thermal dissipation performance.

#### **Photocell**

The luminaire photocell receptacle shall be mounted on the die-cast aluminum housing. The photocell shall be of the 3-prong NEMA twist-lock type.

#### **Optical System**

The luminaire shall contain a precision designed injection molded acrylic optic plate and LED chamber, with a type III distribution pattern. The LED optical system compartment shall be IP 70 rated.

#### **Mounting Bracket Arm**

The luminaire shall be able to be mounted on bracket arms with 1.5- or 2-inch slipfitter tenons. This may include two (2) or four (4) bolt slipfitter bracket assemblies with vertical tilt adjustment range of  $\pm 5\%$ . The mounting bracket area shall be protected with a bird-guard type gasket.



## **Rectilinear (Shoebox)**

### **Purpose**

The purpose of these specifications is to provide minimum requirements for the design, manufacture, fabrication, finishing and delivery of decorative bronze-colored Rectilinear Luminaire with flat glass LED optics, Type III distribution. These luminaires are intended for use on a variety of streetlight poles at a mounting height of 25 feet in urban streetscape and rural areas. Any manufacturer, distributor or vendor who submits a bid shall agree to comply with these specifications and the attached drawings.

### **Description**

Each street light luminaire includes the following.

- a. Die-cast aluminum housing and drop style door.
- b. NEMA standard photoelectric control receptacle on the top cover of the luminaire with NEMA 7-pin twist-lock multi-volt photocell.
- c. All necessary hardware for side mounting on specified pole.
- d. Side-mounting brackets are eight (8) to twelve (12) inches long and rectangular in cross section as specified under quantities required.
- e. Flat, hard tempered glass lens.
- f. Finish color shall be National Park Service Brown.

### **Shape and Minimum Size**

The luminaire shall be rectangular in shape. The actual size may vary depending on the specified wattage. The maximum allowable Effective Projected Area (EPA) for the luminaire and bracket arm shall be three 0.7 or less square feet. The luminaire shall be of a suitable size to accommodate LED optical assembly, type III distribution and associated driver.

### **Wind Load**

All components of the luminaires shall be designed to resist (at yield strength of the materials without permanent deflection or destruction), test loads equivalent to the calculated loads developed by the velocity pressure of at least an 80 MPH wind. A minimum safety factor of 1.82 on the yield strength shall be maintained.

### **Finish**

All Visible components shall be finished to produce the appearance of a decorative "National Park Service Brown" color. During the finishing process, all critical openings shall be plugged to prevent contamination of the threads or reduction of critical openings.

### **Design Uniformity**

These specifications are intended to produce a uniform system of hardware that will minimize the number of stock items that the County or its contractor(s) must maintain.

### **Housing**

The housing shall consist of a watertight shell fabricated with either welded, overlapped seams, or with extrusions sealed with silicon seals. Cast aluminum door frames, to hold the flat tempered prismatic glass lens or a cover concealing the driver, shall be affixed to the housing with full length aluminum piano hinges incorporating removable stainless steel hinge pins. All



doors shall be fully gasketed with closed cell or solid neoprene gaskets. All doors shall be held closed with two quarter-turn captive fasteners and shall be restrained by captive stainless steel or brass chains.

### **Material**

The luminaire housing shall be constructed of cast, extruded or 0.051-inch minimum sheet aluminum.

### **Castings**

All castings used to complete the luminaire shall be clean and smooth with all details well defined and true to pattern.

### **Driver & Surge Protection**

The driver shall be mounted to facilitate easy removal and maintenance operations and replacement. All electrical connections shall be polarized and of plug-in design. The driver shall be equipped with a 10KV surge Protection and suppression system. The driver shall be wired to receive nominal 120 volt AC current. The driver shall reliably start and operate the lamp in ambient temperature down to minus 22 degrees Celsius. The terminal block shall be capable of accepting up to a #6 AWG wire. The assembly shall be completely accessible and removable without requiring access through the reflector assembly.

### **Cooling System**

The luminaire shall include a heat sink with no fans, pumps, or liquids, and shall have wide angular fin to resist debris buildup that may degrade thermal dissipation performance.

### **Optical System**

The luminaire shall contain a precision designed injection molded acrylic optic plate and LED chamber, with type III distribution pattern. The LED optical system compartment shall have a minimum IP70 rating.

### **Photocell**

The photoelectric cell shall be of the 3-prong NEMA twist-lock type and shall be mounted in the top of the luminaire housing.

### **Mounting Bracket Arm**

The bracket shall consist of an extruded rectangular aluminum section, 8.0 to 12.0 inches in length and long enough to permit mounting two luminaires at a 90° angle on any of the following types of poles:

- a) The "Tall-Post Streetlight Pole" with an approximate diameter of 3.5 inches at a nominal ±25 feet mounting height (drawing attached)
- b) A traffic signal pole with an approximate diameter of 9.5 inches at a ±25 feet mounting height.
- c) A traffic signal pole with an approximate diameter of 5.25 inches at a ±25 feet mounting height.



- d) A square tapered pole with an approximate dimension of 4.5 inches at a ±25 feet streetlight mounting height. Predrilled mounting bolt holes in poles are 9/16 inches large and 3.0 inches between centers. A 0.75 inch hole for wires is located between the bolt holes.
- e) A rectangular tapered wood pole with approximate dimensions of 5 inches x 6 inches at a ±25 feet mounting height.
- f) A square and dovetail pole at approximate height of 30 feet.

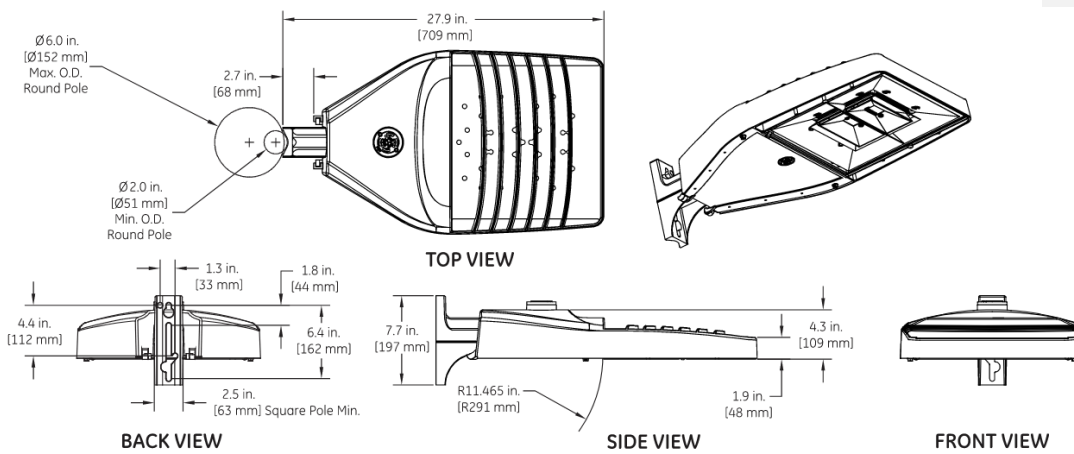



## **Silver Spring Pedestrian Tear Drop**

### **Purpose**

The purpose of these specifications is to provide minimum requirements for the design, manufacture, finishing and delivery of the Silver Spring Pedestrian LED Shallow drop style luminaires. The Silver Spring Pedestrian LED Shallow drop is intended to be mounted on a decorative post as specified, along roadways in the Silver Spring Central Business District. Any manufacturer, distributor or vendor who submits a bid shall agree to comply with these specifications or submit specifications for approval that match these specifications.

### **Description**

The luminaire shall be an outdoor decorative fixture, cylindrical in shape with an overall height of 25.625 inches and an overall width of 14.5 inches for the globe (see attached drawing). All exterior and structural parts shall consist of cast aluminum alloy. Exterior castings shall be cast in three pieces having a smooth surface finish and free of mold lines. A separate section for the driver is permitted if the driver casting is secured to the luminaire body with stainless steel captive fasteners. All components shall fit together snugly and shall be fitted with continuous neoprene gaskets so as to weatherproof the joints between metal interfaces. Visible metal surfaces shall be integrally molded as to appear to be a single unit. All metal parts shall be corrosion resistant. The luminaire shall come ready for quick and easy field assembly or be fully assembled and include the following components:

- a. LED Optical Assembly (Type III distribution).
- b. 120 volt LED Driver.
- c. NEMA twist-lock type photocell installed on the metal body of the decorative post.
- d. Shallow Drop globe.
- e. All necessary hardware and fasteners to assemble and secure the luminaire onto the post arm.

### **Globe**

The globe shall be of a Shallow Drop (teardrop) shape, thermal resistant borosilicate glass or Acrylic that controls the light and provide an IES Type III cutoff distribution. The combination of shallow lens and LED panel shall maximize efficiency and uniformity of illumination while controlling the luminaire brightness. The entire globe shall be luminous with shielding of the top section. The top surface of the globe shall interface closely with the metal body of the fixture so as to provide weather, dust, and insect proof protection.

### **Driver & Surge Protector**

The driver shall be mounted to facilitate easy removal for maintenance operations. The driver shall be equipped with a 10kV Surge Protection and suppression system. All electrical connections shall be polarized and of plug-in design. The driver shall be wired to receive 120 volt AC current. The driver shall reliably start and operate the lamp in ambient temperatures down to minus 30 degrees. The terminal block shall be capable of accepting up to a #6 AWG wire.



**Photocell**

The photocell shall be a NEMA twist-lock type or equal, mounted on the metal body of the decorative post.

**Metal Body**

The body shall be cast in two pieces and shall have raised surface ridges. The body shall taper smoothly from the slip fitter to the top of the globe. The body shall be constructed to prevent rainwater collecting on the body.

**Top Entry Threaded Slipfitter**

The top entry threaded slipfitter shall have a nominal inside diameter of 1.5 inches and shall be secured to the pole slipfitter with three or four evenly spaced setscrews or approved top mounting equivalence.

**Finish**

The exterior surface of the luminaire body shall be factory finished with a dark green electrostatically applied polyester powder coat. The color shall be SAE AMS-STD-595A, Color 14036, Federal Green.

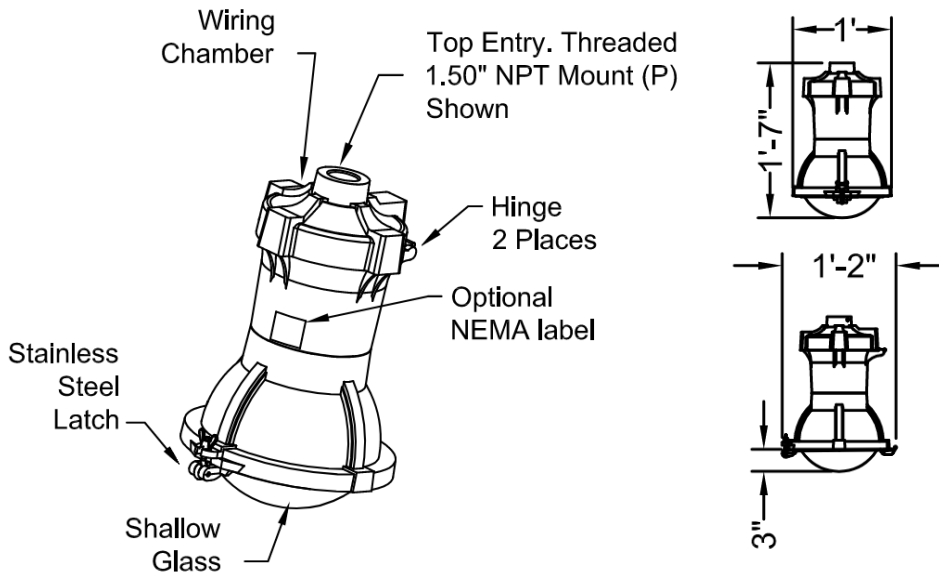



## **Silver Spring Vehicular Tear Drop**

### **Purpose**

The purpose of these specifications is to provide minimum requirements for the design, manufacture, finishing and delivery of the Silver Spring Pedestrian Teardrop style luminaires. The Silver Spring Pedestrian Teardrop is intended to be mounted on a decorative post as specified, along roadways in the Silver Spring Central Business District. Any manufacturer, distributor or vendor who submits a bid shall agree to comply with these specifications, or submit specifications for approval that match these specifications.

### **Description**

The luminaire shall be an outdoor decorative fixture, cylindrical in shape with an overall height of 25.625 inches and an overall width of 14.5 inches for the globe (see attached drawing). All exterior and structural parts shall consist of aluminum alloy. Exterior castings shall be cast in three pieces having a smooth surface finish and free of mold lines. A separate section for the ballast is permitted if the ballast casting is secured to the luminaire body with stainless steel captive fasteners. All components shall fit together snugly and shall be fitted with continuous neoprene gaskets so as to weatherproof the joints between metal interfaces. Visible metal surfaces shall be integrally molded as to appear to be a single unit. All metal parts shall be corrosion resistant. The luminaire shall come ready for quick and easy field assembly or be fully assembled and include the following components:

- a. Lamp, as specified.
- b. 120 volt ballast.
- c. NEMA twist-lock type photocell installed on the metal body of the decorative post.
- d. All necessary hardware and fasteners to assemble and secure the luminaire onto the post arm.

### **Globe And Refractor**

The globe shall be of the traditional "Atlanta" (teardrop) shape, thermal resistant borosilicate glass refractor that controls the light, and provide an IES Type III cutoff distribution. The combination of reflector, refractor and vertical burning lamp shall maximize efficiency and uniformity of illumination while controlling the luminaire brightness. The entire globe shall be luminous with shielding of the top section. The top surface of the globe shall interface closely with the metal body of the fixture so as to provide weather, dust, and insect proof protection.

### **Photocell**

The photocell shall be a NEMA twist-lock type or equal, mounted on the metal body of the decorative post.

### **Metal Body**

The body shall be cast in two pieces and shall have raised surface ridges. The body shall taper smoothly from the slip fitter to the top of the globe. The body shall be constructed to prevent rainwater collecting on the body.



**Top Entry Threaded Slipfitter**

The top entry threaded slipfitter shall have a nominal inside diameter of 1.5 inches and shall be secured to the pole slipfitter with three or four evenly spaced setscrews.

**Finish**

The exterior surface of the luminaire body shall be factory finished with a dark green electrostatically applied polyester powder coat. The color shall be SAE AMS-STD-595A, Color 14036, Federal Green.

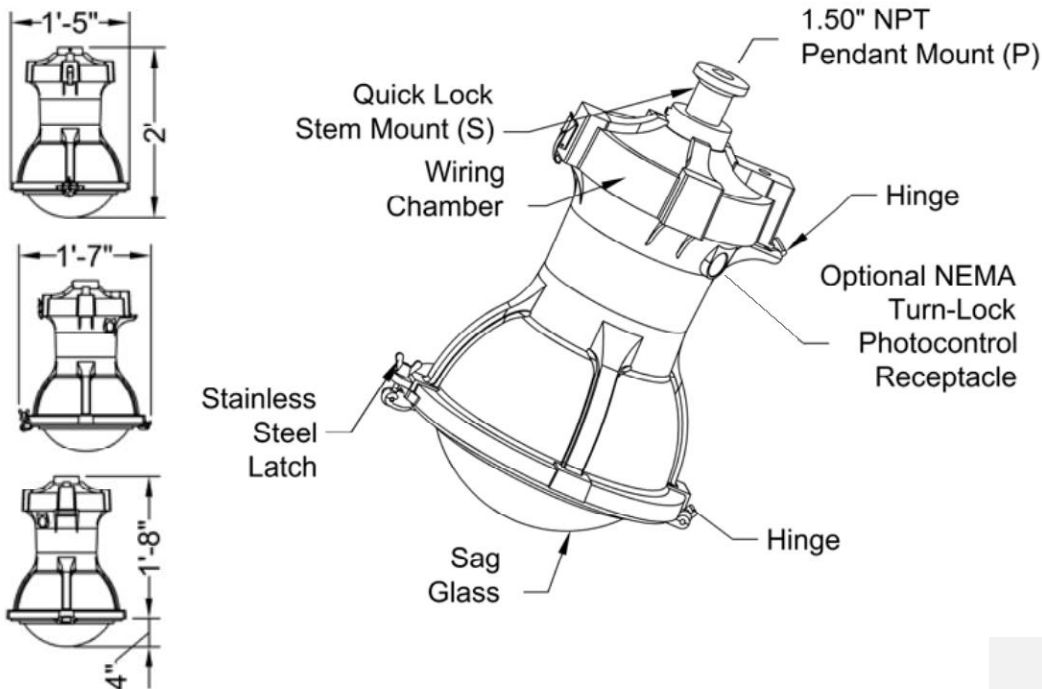





## **Contemporary Post Top (Wheaton Pedestrian)**

### **Purpose**

The purpose of these specifications is to provide minimum requirements for the design, manufacture, finishing and delivery of the Wheaton decorative LED pedestrian luminaires. The Wheaton decorative LED pedestrian luminaire is intended to be mounted on decorative pole in urban streetscaped areas in Montgomery County. Any manufacturer, distributor or vendor who submits a bid shall agree to comply with these specifications.

### **Description**

The U.L. approved luminaire is round in shape, has four "PILLARS" to support the top of the fixture and 21 inches ( $\pm 1$  inch) in diameter, designed to be used as an outdoor streetlight. The luminaire shall provide a Type III distribution.

Each luminaire shall include the following:

- a. LED optical assembly in the top of the fixture.
- b. 120 volt LED Driver
- c. 10KV Surge Suppression Device built in
- d. The finish color shall match semi-gloss black thermosetting, polyester powder coating.
- e. Heavy duty cast aluminum fitter assembly which supports the optical assembly.
- f. Button type photoelectric cell to be installed in the base of the luminaire fixture (see attached detail).
- g. All necessary hardware required for mounting on Wheaton Pedestrian poles.
- h. The luminaire must be of suitable size to accommodate an LED array and driver.

### **Optical Assembly**

The optical assembly shall consist of high precision refractive lenses mounted above the LED emitter arrays in such a way to achieve optimum upright control. The lenses shall also control horizontal light distribution patterns are achieved. The optical assembly shall be finished with high temperature gloss black oven cured enamel. The assembly shall be secured to the luminaire with the four pillars.

### **Housing**

The housing shall consist of heavy grade A319 cast aluminum. The main body, or capital, acts as an enclosure for the driver assembly and is of adequate thickness so as to give sufficient structural rigidity. The capital shall have an opening at the base of the tenon body to allow the luminaire to be mounted to a tenon of 3.5-inch maximum diameter.

### **Driver & Surge Protection**

The driver shall be mounted to facilitate easy removal for maintenance operations. The driver shall be equipped with a 10kV Surge Protection and suppression system. All electrical connections shall be polarized and of plug-in design. The driver shall be wired to receive 120 volt AC current. The driver shall reliably start and operate the lamp in ambient temperatures down to minus 30 degrees. The terminal block shall be capable of accepting up to a #6 AWG wire.



**Photocell**

The photocell shall be a "U.L. approved" twist-lock type or equal. The photoelectric cell shall be located in the base of the luminaire fixture. (See attached detail.)

**Corrosion Protection**

The complete luminaire assembly must be U.L. listed as "Suitable for Wet Locations." The U.L. listing number shall be submitted with the bid. All exposed metal parts of the luminaire shall be protected against corrosive environments by alkaline cleaning, zinc phosphate pretreatment and Triglycidyl Isocyanurate polyester powder paint.



## **Wheaton Vehicular Luminaire**

### **Purpose**

The purpose of these specifications is to provide minimum requirements for the design, manufacture, fabrication, finishing and delivery of a Wheaton decorative LED optics vehicular luminaire with Type III distribution shall be made of low copper die-cast aluminum housing. The roadway, LED, style luminaire is intended for use along roadways in Montgomery County. Any manufacturer, distributor or vendor who submits a bid shall agree to comply with these specifications and the attached drawings.

### **Description**

Each streetlight luminaire includes the following:

- a. Die-cast aluminum housing and drop style door.
- b. 120 volt LED Driver.
- c. LED Optical Assembly (Type III distribution).
- d. NEMA 3-prong twist-lock standard photoelectric control receptacle on the top of the luminaire.
- e. NEMA 3-prong twist-lock multi-volt standard photocell.
- f. All necessary hardware required for mounting on bracket arm, as specified.

### **Shape and Minimum Size**

- a. The luminaire shall be of a rounded rectangular shape. The actual luminaire size may vary depending on the specified wattage.
- b. The luminaire shall be suitable to accommodate several LED Optical Assembly (Type III distribution) and associated LED driver.

### **Effective Projected Area (EPA)**

The luminaire shall have a maximum estimated allowable EPA for luminaire of 0.7 SF.

### **Finish**

The luminaire shall have a Gloss Black polyester powder coat finish. During the finishing process, all critical openings shall be plugged to prevent contamination of the threads or reduction of other critical openings.

### **Housing**

The luminaire shall consist of a watertight housing fabricated from low copper die-cast aluminum housing, with die-cast aluminum drop-style doors. The drop-style doors shall be hinged on one side and secured on the opposite side with a captive stainless steel latch or captive stainless steel screw. All castings used to fabricate the luminaire housing shall be clean and smooth, with details defined and true to pattern. The housing shall be suitable to accommodate the LED Optical Assembly and LED driver.

### **Driver & Surge Protection**

The driver shall be mounted to facilitate easy removal for maintenance operations. The driver shall be equipped with a 10kV Surge Protection and suppression system. All electrical connections shall be polarized and of plug-in design. The driver shall be wired to receive 120 volt AC current. The driver shall reliably start and operate the lamp in ambient temperatures



down to minus 30 degrees. The terminal block shall be capable of accepting up to a #6 AWG wire.

**Cooling System**

The luminaire shall consist of a heat sink with no fans, pumps, or liquids, and shall have wide angular fin in design to be resistant debris buildup that may degrade thermal dissipation performance.

**Photocell**

The luminaire photocell receptacle shall be mounted on the die-cast aluminum housing. The photocell shall be of the 3-prong NEMA twist-lock type.

**Optical System**

The luminaire shall contain a precision designed injection molded acrylic optic plate and LED chamber, with a type III distribution pattern. The LED optical system compartment shall be IP 66 rated.

**Mounting Bracket Arm**

The luminaire shall be able to be mounted on bracket arms with 1.5- or 2-inch slipfitter tenons. This may include two (2) or four (4) bolt slipfitter bracket assemblies with vertical tilt adjustment range of  $\pm 5\%$ . The mounting bracket area shall be protected with a bird-guard type gasket.



## Recessed or Surface Mounted (Wall Pack)

### **Purpose**

The purpose of these specifications is to prescribe the minimum requirements for the design, manufacture, fabrication, finishing and delivery of recessed/surface mounted or wall pack luminaire. The recessed/surface mounted directional luminaires are intended for use in areas that require low level lighting with elongated symmetrical distribution and shallow forward lighting (i.e. high pedestrian traffic areas, streetscape areas) mounted in or on concrete walls. Any manufacturer, distributor or vendor who submits a bid shall agree to comply with these specifications and attached drawings.

### **Description**

This luminaire shall be an outdoor fixture, rectangular in shape with an overall height between 8 and 10 inches, a width between 8 and 14 inches, and a depth between 7 and 10 inches. The fixture shall mount to standard round, octagonal, or square electrical junction boxes. All necessary hardware and fasteners to assemble and install on and/or into walls concrete prior to concrete placement shall be included. The luminaire shall UL listed to UL Standard 1598, suitable for wet locations and ambient temperatures from -40° to 40° C.

### **Housing**

The housing and lens frame shall be die-cast aluminum.

### **Lens**

The lens shall be heat and impact resistant borosilicate glass.

### **Driver & Surge Suppression**

The LED light engine shall be weatherproof, rated IP 65 or better. The LED driver efficiency shall be greater than 80% at full load. Surge protection up to 10 kV.

### **Photocell**

No photocell required.

### **Exterior Finish**

The finish shall be fade and abrasion resistant, electrostatically applied, thermally cured, triglycidal isocyanurate (TGIC) textured polyester powdercoat finish, bronze or brown in color. SAE AMS-STD-595A, Color 20040, National Park Service Brown.

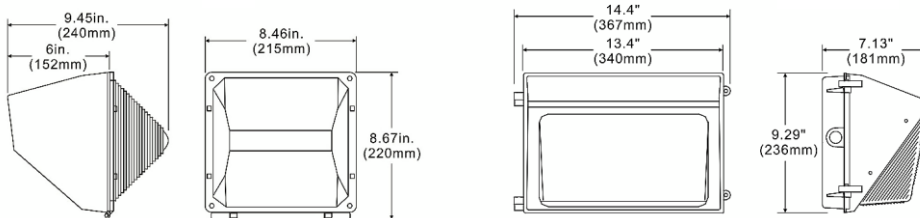



## **Pedestrian Underpass**

### **Purpose**

The purpose of these specifications is to provide minimum requirements for the design, manufacture, fabrication, finishing and delivery of ceiling mounted, pedestrian underpass luminaires. These luminaires are intended for use in tunnels throughout Montgomery County. Any manufacturer, distributor or vendor who submits a bid shall agree to comply with these specifications and the attached drawings.

### **Description**

Each streetlight luminaire shall include the following:

- a. Lamp, as specified.
- b. Dropped polycarbonate refractor.
- c. All necessary hardware for ceiling mounting.
- d. National Park Service Brown finishing.

### **Shape and Minimum Size**

The luminaire shall be square in shape. The minimum size for the luminaire shall be 22 inches (sum of the luminaire's length plus width), when viewed from the side.

### **Finish**

All Visible components shall be finished to produce the appearance of a decorative National Park Service Brown color. During the finishing process, all critical openings shall be plugged to prevent contamination of the threads or reduction of critical openings.

### **Design Uniformity**

These Specifications are intended to produce a uniform system of hardware, that will minimize the number of stock items that the County or its contractor(s) must maintain.

### **Housing**

The housing shall consist of a watertight shell fabricated with either welded, overlapped seams, or with extrusions sealed with silicon seals. The unit shall be completely sealed by a rubber gasket. The reflector shall be held closed with a minimum of two captive fasteners.

### **Material**

The luminaire housing shall be completely waterproof and constructed of formed aluminum.

### **Castings**

All castings used to complete the luminaire shall be clean and smooth, with all details well defined and true pattern.

### **Reflector**

The reflector shall be a one-piece dropped formed polycarbonate.



## Pole Tags

### Streetlight Pole Numbering Tags

#### **Design Criteria**

The streetlight post numbering tags shall be made of aluminum and finished with a similar color coating as that of the streetlight pole it is to be rigidly attached to. This streetlight post numbering tag is intended for use on all streetlight post maintained by Montgomery County.

Each pole numbering tag shall:

- a. Be 2 inches wide by 12 inches high.
- b. Be a color similar to the streetlight pole.
- c. Have 5 numbers of an opposite color placed vertically.
- d. Have all White/Silver surfaces shall be made of retroreflective sheeting.
- e. Have all colored surfaces shall be non-reflective.

#### **Materials & Fabrication**

##### Tag

The streetlight post numbering tags shall be 2 inches wide by 12 inches high, fabricated from clear anodized 1/16-inch thick aluminum. The edges shall be smooth and corners rounded and the tag shall fit the streetlight pole shaft.

##### Reflective Areas

The streetlight post numbering tag reflective area shall conform to D4956, Type III retroreflective sheeting.

##### Non-Reflective Areas

The streetlight post numbering tags non-reflective areas shall be as follows:

- a. Numbers on white/silver reflective post tag
- b. Backing on all other streetlight post tags

##### Hardware

The streetlight post numbering tag shall be secured to the shaft of the streetlight by a means of two (2) 0.125-inch diameter, 18-8 stainless steel tamper-proof screws.

#### **Mounting**

##### Height

The streetlight post numbering tag should be mounted at a height approximately 10 feet from the surrounding elevation of the ground, unless otherwise approved and directed by the Engineer.

##### Orientation

The streetlight post numbering tag shall be oriented and rigidly mounted at a 30- to 45-degree angle, so that approaching traffic can readily observe the tags numbers.



**Numbers**

The streetlight post numbering tag numbers shall be a minimum of 2 inches high with a minimum 0.25-inch stroke width.

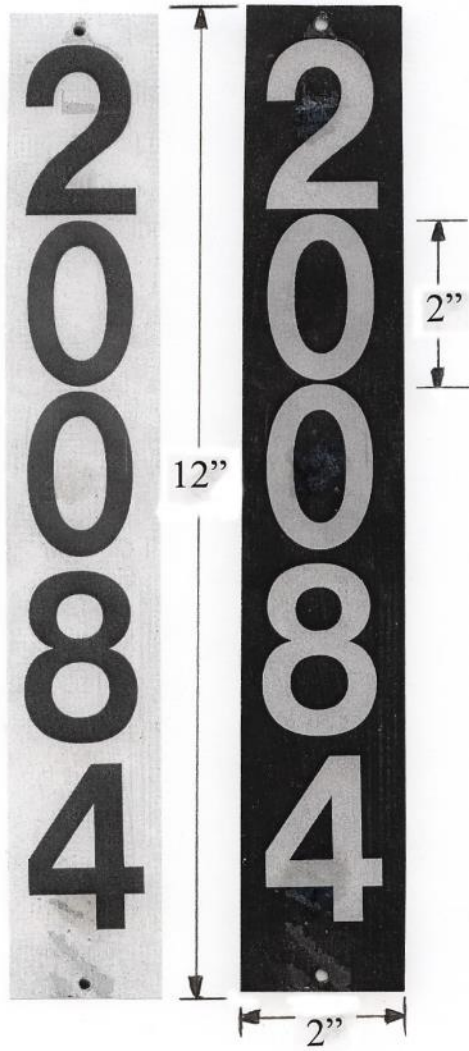





## Small Cell Streetlight Poles

### Telecommunication Small Cell Pole Installations

#### **Description**

This document prescribes the general requirements for the design and manufacture of streetlight poles incorporating telecommunication small cell equipment. The objective is to replace the County's existing streetlight poles with specialty poles that are designed and manufactured for the additional equipment and the associated load. For the purpose of this document, these streetlight poles shall be referred to as "Small Cell Poles".

The County owns and maintains several different streetlight types. While most of the requirements are generic and apply to all types of streetlights, some requirements are specific as outlined in this document.

#### **General Specifications**

Any Small Cell Pole to be used in Montgomery County shall:

1. Be reviewed and approved by DTEO prior to installation.
2. Have a context-uniform design matching the aesthetics and the general shape of the streetlight pole it replaces.
3. Use context uniform paint, galvanizing, or other finishing needed to match the aesthetics color of the existing streetlight pole it replaces.
4. Be of the same material as the streetlight pole it replaces, unless the existing pole is fiberglass, in which case, Cast Aluminum or Steel shall be used.
5. Shall have the structural integrity to support the weight of the existing streetlight fixture, traffic signs (if any), and the weight of all of the communication equipment expected to be mounted on it.
6. Be equipped with all necessary holes for attachment of the equipment such that field drilling or welding directly to the pole is not necessary.
7. Have a circular base cabinet, no larger than 18 inches in diameter and 72 inches in height, for housing telecommunication small cell equipment, utility meter (if any), and the lighting disconnect box.
8. Have a shaft that is similar in size and shape to the pole it replaces.
9. Be single piece from bottom to the top.
10. Be equipped with up to two sets of hardware suitable for mounting antennas as required for telecommunication small cell equipment.
11. Be equipped with a horizontal mast arm (two horizontal mast arms in case of Silver Spring vehicular & pedestrian poles) using the same tenant size for mounting of the fixture(s).
12. Be equipped with the necessary anchor bolts and associated hardware; and
13. Be equipped with a crash-worthy breakaway base when installed within the clear zone.

#### **General Guidelines**

##### Telecommunications Small Cell Components

Each pole is permitted to have the following characteristics for telecommunications use:

- a. **Base.** A wide base (base cabinet) for housing telecommunications small cell equipment. The base cabinet shall be circular, limited to 18 inches in diameter and 72 inches high.



The top of the base cabinet shall have a gradual transition or tapered section to the main pole section and this transition or tapered section shall meet the requirements below for Context Uniformity and Aesthetics. All communication equipment shall be placed inside the base cabinet, except for the antenna(s) that will be mounted on the pole. No ground-mounted equipment is permitted for use with a Small Cell Pole.

- b. **Shaft.** Similar in size and shape to the existing pole being replaced but designed to accommodate the light and antenna(s).
- c. **Antenna.** One antenna, placed at the top of the pole, limited to 5 feet in height. Another antenna (if necessary) may be placed below the horizontal mast arms.

See attached drawing at the end of this specification for additional details.

#### Context Uniformity and Aesthetics

Each pole shall have a context-uniform design and shall match the aesthetics of any nearby MCDOT streetlight poles. Context-uniformity includes the materials, light pole shaft, horizontal mast arms, receptacles, luminaires, and finish. Specifications of nearby MCDOT streetlight poles can be provided for use in developing a context-uniform design. The base cabinet and antennas shall be designed to meet this context uniform design as closely as possible.

#### Effective Projected Area (EPA)

The pole and associated components and attachments shall have an EPA with the following requirements:

- a. Streetlight luminaires, mast arms, and traffic signs shall meet the EPA requirements of the associated nearby MCDOT streetlight poles as required for context uniformity.
- b. All antennas above the equipment base cabinet shall have a combined EPA less than 16 square feet.

#### Breakaway/Crash Requirements

The final pole including all attachments and telecommunications equipment shall incorporate breakaway devices when the pole is located in the roadway clear zone and may be impacted by a vehicle. All breakaway devices shall meet the requirements of the AASHTO Manual for Assessing Safety Hardware (MASH) Second Edition, dated 2016.

### **Materials**

#### Pole and Mast Arms

The pole, including base cabinet and mast arm (s) shall meet the material requirements of the existing pole it replaces. If the existing light pole is made of fiberglass material, cast aluminum or steel shall be used.

#### Caisson

The concrete for the caisson foundation shall have a minimum 28-day compressive strength of 3,000 PSI. All reinforcing steel shall be Grade 60 with 60,000 PSI yield strength.

#### Base Plate

A 1.25 inch thick (minimum) steel base plate sufficient to fully develop the ultimate strength of the pole shall be secured to the base of the equipment base cabinet.



#### Anchor Bolts

Anchor bolts shall conform to the requirements of ASTM F1554 and shall have a minimum yield strength of 55,000 psi. All anchor bolts and associated hardware shall be galvanized in accordance with ASTM A153.

#### **Telecommunication Small Cell Equipment**

With the exception of the antenna(s), all telecommunication small cell equipment shall be housed inside the base cabinet, above the breakaway system. No communication equipment, other than the antenna(s) is permitted to be installed on the pole. Access to the Montgomery County lighting cables, meter, and/or disconnect box shall be provided in the base cabinet.

#### **Height**

The total height of the pole, including antenna, shall not exceed 35 feet. The height of the antenna at the top of the pole shall not exceed 5 feet.

#### **Anchor Bolts**

Each pole shall be supplied with a minimum of four (4) steel anchor bolts with a 1.25-inch diameter extending 42 inches into the caisson. The anchor bolts shall be arranged in a circular pattern with a diameter of 15 inches. The anchor bolts shall be connected to a 0.5-inch anchor plate located in the caisson foundation and secured with nuts and washers on both sides of the anchor plate. A 0.25-inch thick steel template shall be provided for the installation of the anchor bolts.

#### **Pole Caisson Foundation**

The pole shall be supported on a concrete caisson foundation. The caisson shall have a diameter of 2 feet 6 inches and shall have reinforcing steel as shown in the attached drawing. 3-inch Schedule 40 nonmetallic conduits shall be placed in the caisson, as needed, for electric and telecommunication cables. At the top of the caisson, two triangular grooves shall be provided for drainage. The total length of the buried portion of the caisson shall be a minimum of 7 feet See attached drawing for additional details.