

16998 OVERHILL ROAD

PRELIMINARY PLAN PLAN #120240060

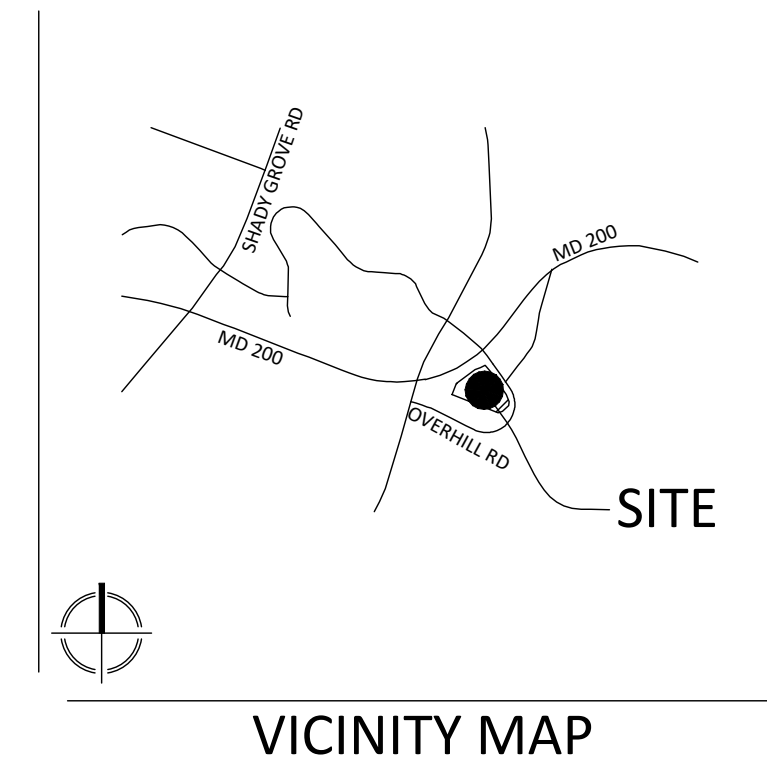

VKA
VKA MARYLAND, LLC
20251 Century Blvd., Suite 400
Germantown, MD 20874
301.916.4100 | vka.com
Our Site Set on the Future.

PREPARED FOR:
**COMMUNITY HOUSING
INITIATIVE, INC.**
1123 ORMOND COURT
MCLEAN, VA 22101
CONTACT: PATRICK BYRNE
(703) 556-9569
pbyrne@chidc.org

PLANNER/ENGINEER/LANDSCAPE
ARCHITECT:
VKA MARYLAND, LLC.
20251 CENTURY BLVD., SUITE 400
GERMANTOWN, MD 20874
CONTACT: JOSH SLOAN
(301) 916-4100
sloan@vka.com

ARCHITECT:
STUDIO K
7806 JAKI TERRACE
GLEN BURNE, MD 21060
CONTACT: CHIP KEENER
(301) 938-5195
ckeener@studiokarch.net

TRAFFIC ENGINEER:
**LENHART TRAFFIC
CONSULTING, INC.**
645 BALTIMORE ANNAPOLIS BLVD.
SUITE 214
SEVERNA PARK, MD 21146
CONTACT: NICK DRIBAN
(410) 216-3333
mlenhart@lenharttraffic.com

ATTORNEY:
MILES & STOCKBRIDGE
11 NORTH WASHINGTON STREET
SUITE 700
ROCKVILLE, MD 20850
CONTACT: SCOTT WALLACE
(301) 762-1500
swallace@MilesStockbridge.com

USE STANDARDS

Section 3.3.2.C.2.c. Independent Living for Seniors as a Conditional Use.

i. The site has adequate accessibility to public transportation, medical services, shopping areas, recreation, and other community services, as described in the and Land Use Report.

ii. No ancillary or retail facilities are proposed.

iii. The affordable housing requirement will be met on site by agreement with the DHCA.

iv. The maximum building height is met per the table below. The maximum density is established by the Hearing Examiner per the table below.

v. Height density, coverage, and parking are compatible with surrounding uses as shown in the Conditional Use Plan application.

vi. The front setback is 50 feet.

vii. There are not abutting lots.

viii. The minimum green area is 50%.

ix. Principal building setbacks (not modified above) meet the minimum required for the subject building type in the R-30 zone, as shown below.

STANDARD	REQUIRED/ALLOWED	APPROVED BY CONDITIONAL USE PLAN	PROPOSED BY PRELIMINARY PLAN
Lot area (min) (Section 4.4.6.B.3)	40,000 SF	164,713 SF	- SF
Tract (Gross Tract) Area		164,713 SF 3.78 AC	- SF - AC
Dedication Required		- SF - AC	- SF - AC
Site (Net Lot) Area		164,713 SF 3.78 AC	- SF - AC
Lot width at front building line (min) (Section 4.4.6.B.3)	125 feet	187 feet	187 feet
Lot width at front lot line (min) (Section 4.4.6.B.3)	25 feet	177 feet	177 feet
Frontage on street (Section 4.4.6.B.3)	Required	Provided	Provided
Lot Coverage (max) (Section 4.4.6.B.3)	15%	15%	15%
	24,707 SF 0.57 AC	24,707 SF 0.57 AC	- SF 0.57 AC
Density (max) (Section 3.3.2.C.2.c.iv.)			
Total Units	n/a units	130 units	130 units
Affordable Units	30 % MPDUs	100 % MPDUs	100 % MPDUs
Main Building Setbacks (min) (Sections 4.4.6.B.2 & 3.3.2.E.2.c.iv.vi.)			
Front	50 feet	50 feet	50 feet
Side Street	20 feet	20 feet	20 feet
Side	25 feet	n/a (no abutting lot)	n/a (no abutting lot)
Sum of Side	35 feet	n/a (no abutting lot)	n/a (no abutting lot)
Rear	25 feet	n/a (no abutting lot)	n/a (no abutting lot)
Height (max) (Section 3.3.2.C.2.c.iv.)	60 feet	60 feet	60 feet
Green Area (min) (Section 3.3.2.C.2.c.viii.)	50%	50%	50%
	82,356 SF 1.89 AC	82,356 SF 1.89 AC	82,356 SF 1.89 AC

STANDARD	REQUIRED/ALLOWED	APPROVED	PROPOSED
Parking (min) (Division 6.2)			
Total Parking Spaces	0.75 = 98	123	123
Standard Spaces	93	116	116
Handicapped Spaces	3	4	5
Motorcycle/Scooter Spaces	2	3	2
Bicycle Parking Per Unit	0.25 = 33	33	33
Parking (min perimeter planting width) (Section 6.2.9.C.3.b.i.)	6 feet	N/A	6 feet
Fences and Walls Height (max) (Section 6.4.3.C.3.e.i.)	6.5 feet	6.5 feet	6.5 feet
	N/A - No Abutting	1.9 FC	1.9 FC

NOTES

[1] The Hearing Examiner may modify height, density, coverage, and parking to maximize the compatibility of buildings with the residential character of the surrounding neighborhood.

[2] Accessory structures are permitted within setbacks, as defined in the Zoning Ordinance.



LOCAL AREA MAP

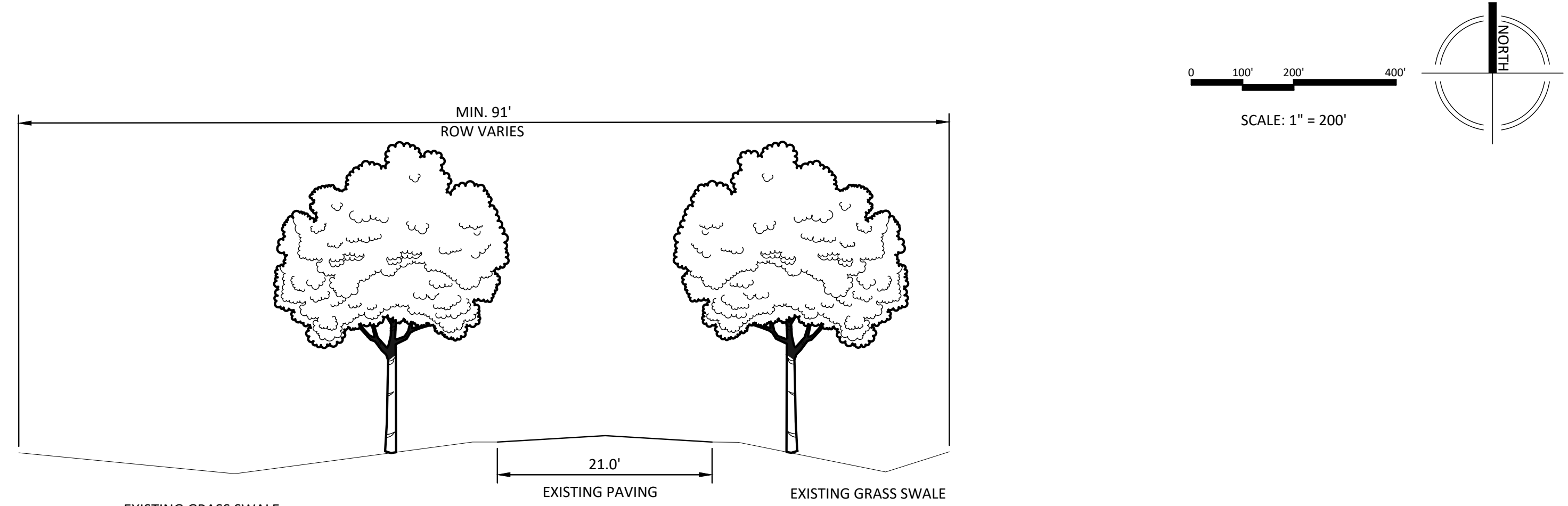

OVERHILL ROAD CROSS SECTION

SCALE: 1"=10'

REFERENCE NOTES

LOT: PART OF LOT 6
BLOCK: D
PLAT: 1581
TAX ACCOUNT REFERENCE: 04-00117554
OWNER: MARK A. JOHNSON
13751 TRAVILAH RD.
ROCKVILLE, MD 20850

RE-1
RE-1
RE-1
CURRENT ZONING: MILL CREEK SUBWATERSHED OF THE UPPER ROCK CREEK
PROPOSED ZONING: W-1
APPROVED NRI NO: S-1
WATERSHED: 2B; 2C; 6A; 116D
WATER SERVICE CATEGORY: 'X'
SEWER SERVICE CATEGORY: 'X'
FLOODPLAIN ZONE: 'X'
FIRM COMMUNITY PANEL NO.: [24031C04 550], FOR MONTGOMERY COUNTY, MARYLAND, DATED SEPTEMBER 29, 2006.

GENERAL NOTES

- THE HORIZONTAL DATUM IS MARYLAND STATE GRID NORTH (NAD83) AND THE VERTICAL DATUM IS NAVD83.
- THERE ARE NO WETLANDS, WATERS OF THE UNITED STATES, OR 100 YEAR FLOOD PLAINS LOCATED ON THE SUBJECT PROPERTY.
- THERE ARE NO FORESTED AREAS LOCATED ON THE SUBJECT PROPERTY AS DEFINED BY MONTGOMERY COUNTY FOREST LEGISLATION.
- THERE ARE NO RARE, THREATENED OR ENDANGERED PLANTS, ANIMALS, OR CRITICAL HABITATS ON THIS PROPERTY.
- THE SUBJECT PROPERTY IS NOT IDENTIFIED IN THE MONTGOMERY COUNTY HISTORICAL ATLAS.
- CHANGES TO THIS PLAN THAT DO NOT CONFLICT WITH THE CONDITIONS OF APPROVAL DUE TO FINAL ENGINEERING REQUIRED AS A RESULT OF PUBLIC AGENCY REVIEW, SUBSEQUENT TO THE APPROVAL OF THE CERTIFIED PRELIMINARY PLAN, ARE ALLOWED AND DO NOT REQUIRE AMENDMENTS TO THIS PLAN BY THE MONTGOMERY COUNTY PLANNING BOARD.
- UNLESS SPECIFICALLY NOTED ON THIS PLAN DRAWING OR IN THE PLANNING BOARD CONDITIONS OF APPROVAL, THE BUILDING FOOTPRINTS, BUILDING HEIGHTS, ON-SITE PARKING, SITE CIRCULATION, AND SIDEWALKS SHOWN ON THE PRELIMINARY PLAN ARE ILLUSTRATIVE. THE FINAL LOCATION OF BUILDINGS, STRUCTURES AND HARDSCAPE, IS DETERMINED AT THE TIME OF CONDITIONAL USE APPROVAL. PLEASE REFER TO THE ZONING DATA TABLE FOR DEVELOPMENT STANDARDS SUCH AS SETBACKS, BUILDING RESTRICTION LINES, BUILDING HEIGHT, AND LOT COVERAGE FOR EACH LOT.
- AN ON-SITE PRE-CONSTRUCTION MEETING IS REQUIRED TO BE SET UP WITH THE MNCPPC INSPECTION STAFF BEFORE ANY DEMOLITION, CLEARING, OR GRADING OCCURS ON-SITE. THE OWNER OR HIS DESIGNEE WHO HAS SIGNATURE AUTHORITY, AND THE GENERAL CONTRACTOR MUST ATTEND THE PRE-CONSTRUCTION MEETING WITH THE MNCPPC INSPECTOR. A COPY OF THE APPROVED CONDITIONAL USE PLAN AND CERTIFIED PRELIMINARY PLAN IS REQUIRED TO BE ON-SITE AT ALL TIMES. TO SCHEDULE AN INSPECTION WITH MNCPPC STAFF, PLEASE CONTACT JOSH KAYE AT 301-495-4722.
- ALL LANDSCAPE AND SITE PLAN AMENITY ELEMENTS TO BE PROVIDED PER APPROVED CONDITIONAL USE PLAN.

SHEET INDEX

- PP-001 COVER SHEET
- PP-002 PLAN APPROVALS
- PP-003 PRELIMINARY PLAN

**16998
OVERHILL
ROAD**

4TH ELECTION DISTRICT
MONTGOMERY COUNTY,
MARYLAND
WSSC GRID: 223NW07
TAX MAP:GT41

**COVER
SHEET**

120240060



I HEREBY CERTIFY THAT THESE DOCUMENTS WERE PREPARED OR APPROVED BY ME, AND THAT I AM A DULY LICENSED PROFESSIONAL ENGINEER UNDER THE LAWS OF THE STATE OF MARYLAND.
LAST NAME: EVANS, JASON A.
LICENSE NUMBER: 33835
EXPIRATION DATE: 12/31/2025

THE INFORMATION, DESIGN AND CONTENT OF THESE DRAWINGS OR DOCUMENTS ARE PROPRIETARY TO VKA MARYLAND, LLC AND CONSTITUTE ITS PROPRIETARY INTELLECTUAL PROPERTY. THESE DRAWINGS, SPECIFICATIONS, AND/OR DOCUMENTS ARE NOT TO BE REPRODUCED, COPIED, DIGITALLY CONVERTED, MODIFIED OR USED FOR ANY PURPOSE, IN ANY FORMAT, WITHOUT THE WRITTEN AUTHORIZATION FROM VKA MARYLAND, LLC. VIOLATION MAY RESULT IN PROSECUTION. ONLY APPROVED, SIGNED AND SEALED PLANS OR DRAWINGS MAY BE UTILIZED FOR CONSTRUCTION PURPOSES.

© 2023 VKA MARYLAND, LLC
DRAWN BY: KP
DESIGNED BY: JS/KP
DATE ISSUED: 11/15/2023
VKA PROJECT: 50571
DRAWING NO.:
SHEET NO.: PP-001

"FOR LOCATION OF UTILITIES CALL 81-1 or 1-800-257-7777 OR LOG ON TO www.call811.com or http://www.missutility.net 48 HOURS IN ADVANCE OF ANY WORK IN THIS VICINITY"

The excavator must notify all public utility companies with underground facilities in the area of proposed excavation and have those facilities located by the utility companies prior to commencing excavation. The excavator is responsible for compliance with requirements of Chapter 33A of the Montgomery County Code.

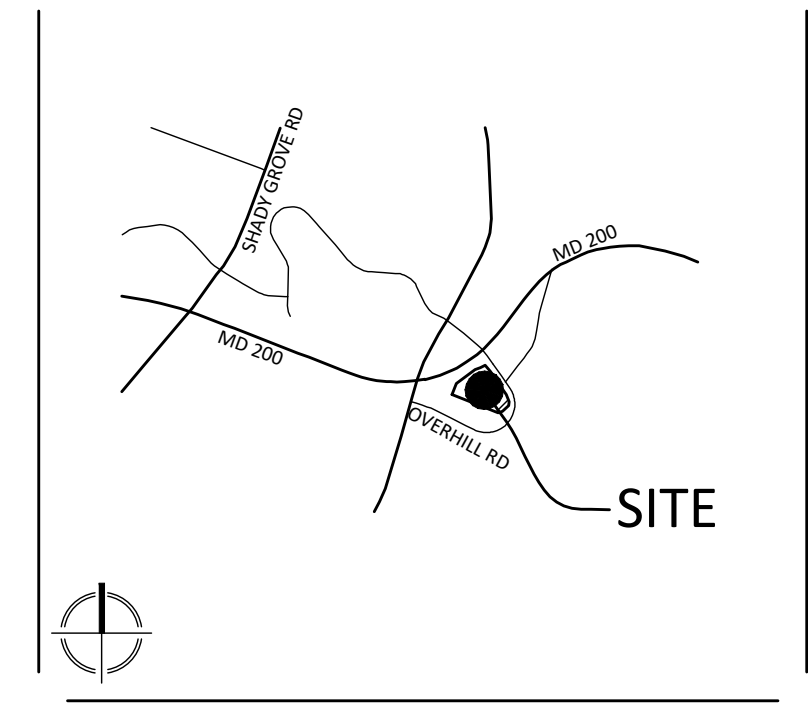
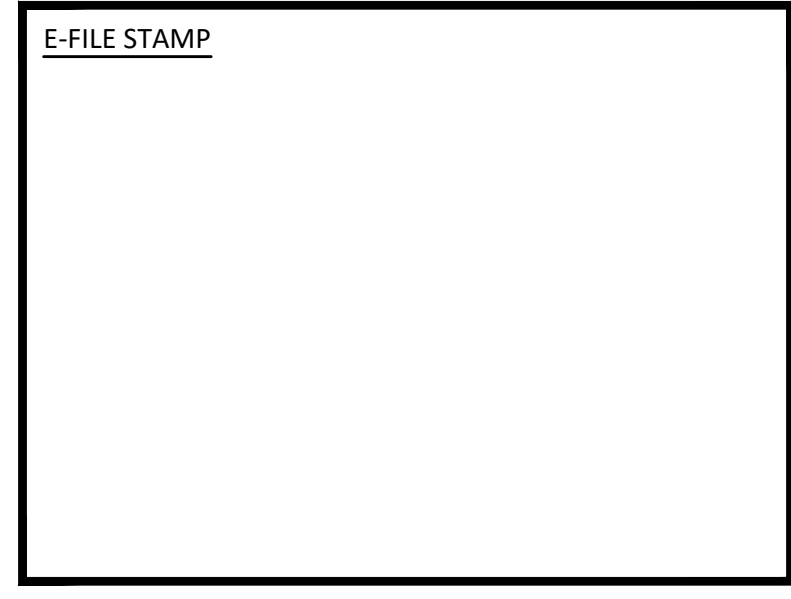

VKA MARYLAND, LLC
20251 Century Blvd., Suite 400
Germantown, MD 20874
301.916.4100 | vika.com
Our Site Set on the Future.
PREPARED FOR:
COMMUNITY HOUSING
INITIATIVE, INC.
1123 ORMOND COURT
MCLEAN, VA 22101
CONTACT: PATRICK BYRNE
(703) 556-9569
pbyrne@chidc.org

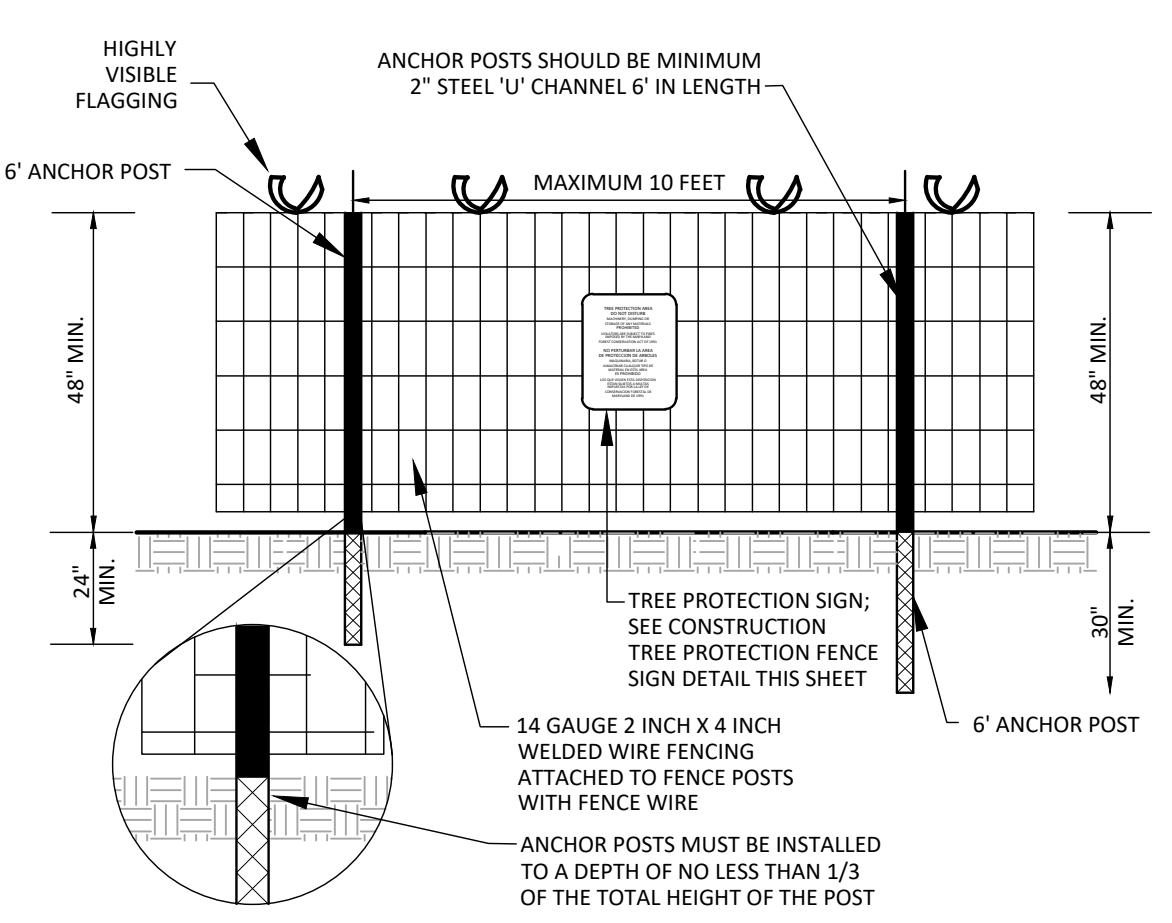

- NOTES:
1. THE BOUNDARIES OF THE LIMITS OF DISTURBANCE SHOULD BE STAKED AND FLAGGED IN COORDINATION WITH THE ARBORIST, DPS AND FOREST CONSERVATION (FC) INSPECTORS PRIOR TO ERECTING THE PROTECTIVE DEVICE.
2. PRACTICE MAY BE COMBINED WITH SEDIMENT AND EROSION CONTROL FENCING AS DETERMINED BY THE ARBORIST, DPS AND FC INSPECTORS.
3. AVOID DAMAGE TO CRITICAL ROOT ZONES OF TREES. ANCHOR POSTS SHOULD BE PLACED TO AVOID SEVERING OR DAMAGING LARGE TREE ROOTS.
4. FENCING MATERIAL SHOULD BE FASTENED SECURELY TO THE ANCHOR POSTS WITH FENCE WIRE.
5. FENCE SIGNS MUST BE PLACED AT A MINIMUM OF 30' APART AND AT FENCE CORNERS, OR AS DIRECTED BY THE FC INSPECTOR. CONDITIONS ON SITE AFFECTING VISIBILITY MAY WARRANT PLACING SIGNS CLOSER OR FURTHER APART. ATTACHING SIGNS TO TREES IS PROHIBITED. SEE CONSTRUCTION TREE PROTECTION FENCE DETAIL, TWO THIS SHEET AND FOR 2 OR 5 YEAR REAFForestation FENCING SEE SIGN DETAIL THREE THIS SHEET.
6. DEVICE SHALL BE MAINTAINED THROUGHOUT CONSTRUCTION. DO NOT REMOVE WITHOUT APPROVAL OF THE FC INSPECTOR.
7. ADAPTED FROM MONTGOMERY COUNTY M-NCPPC PLANNING DEPARTMENT.

1 CONSTRUCTION TREE PROTECTION FENCE DETAIL NOT TO SCALE

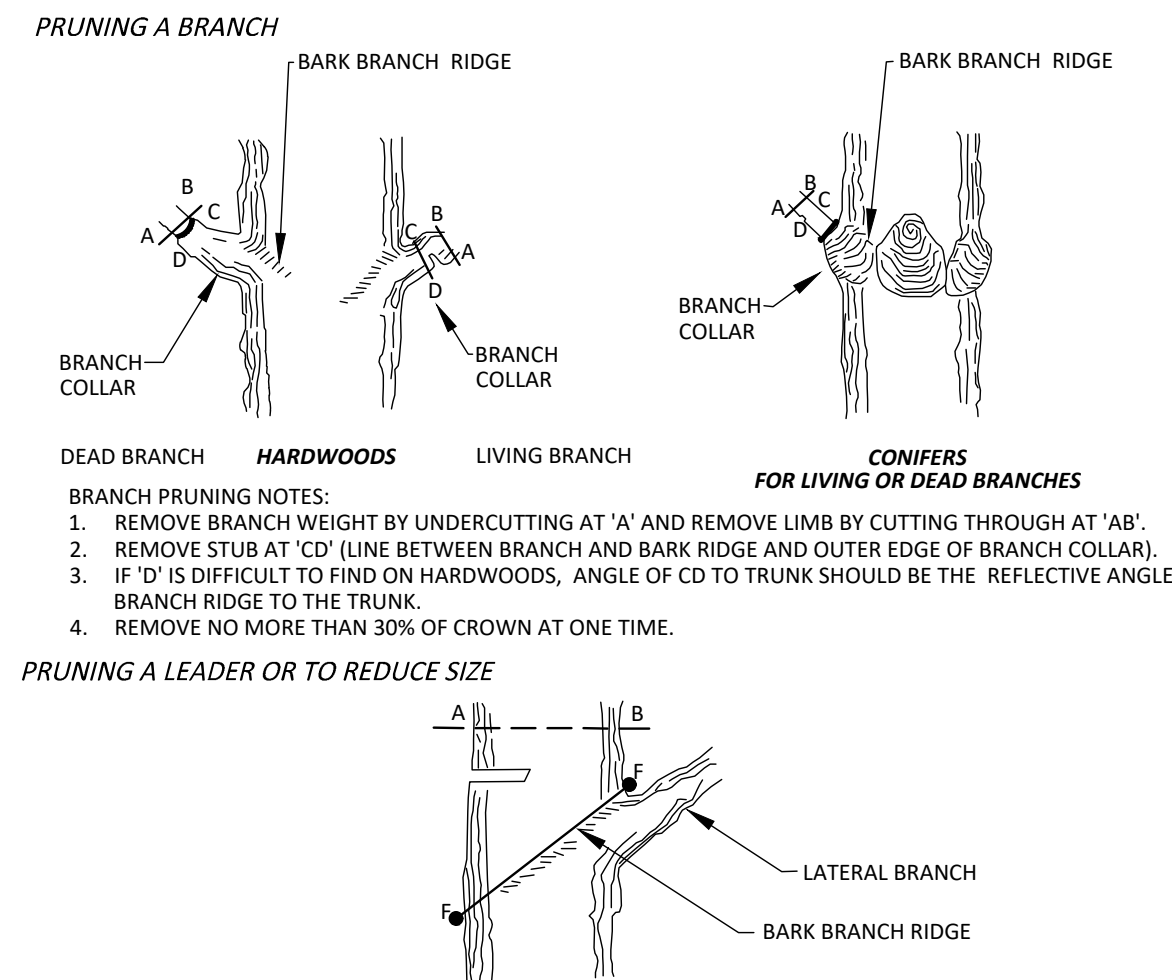

- BRANCH PRUNING NOTES:
1. REMOVE BRANCH WEIGHT BY UNDERCUTTING AT 'A' AND REMOVE LIMB BY CUTTING THROUGH AT 'B'.
2. REMOVE STUB AT 'C' PARALLEL TO THE BARK BRANCH RIDGE.
3. IF 'D' IS DIFFICULT TO FIND ON HARDWOODS, ANGLE OF CUT TO TRUNK SHOULD BE THE REFLECTIVE ANGLE OF THE BARK BRANCH RIDGE TO THE TRUNK.
4. REMOVE NO MORE THAN 30% OF CROWN AT ONE TIME.
LEADER PRUNING NOTES:
1. REMOVE TOP WEIGHT BY UNDERCUTTING AT 'A' AND REMOVE LIMB BY CUTTING THROUGH 'B'.
2. REMOVE STUB AT 'C' PARALLEL TO THE BARK BRANCH RIDGE.
3. TREE PRUNING TO BE PERFORMED BY AN ISA CERTIFIED ARBORIST WHO IS ALSO A LICENSED MARYLAND TREE EXPERT, IN COORDINATION WITH THE FOREST CONSERVATION INSPECTOR.
4. ADAPTED FROM THE MARYLAND STATE FOREST CONSERVATION MANUAL, THIRD EDITION, 1997.

5 TREE BRANCH AND LEADER PRUNING DETAIL NOT TO SCALE

TYPICAL FOREST TREE DISTRIBUTION PATTERNS

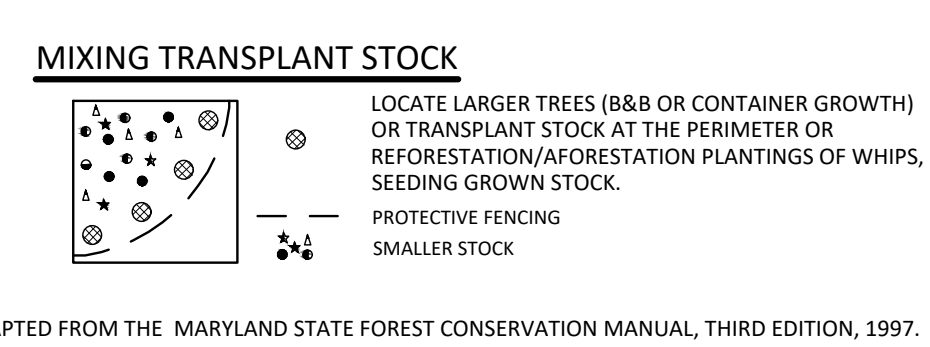
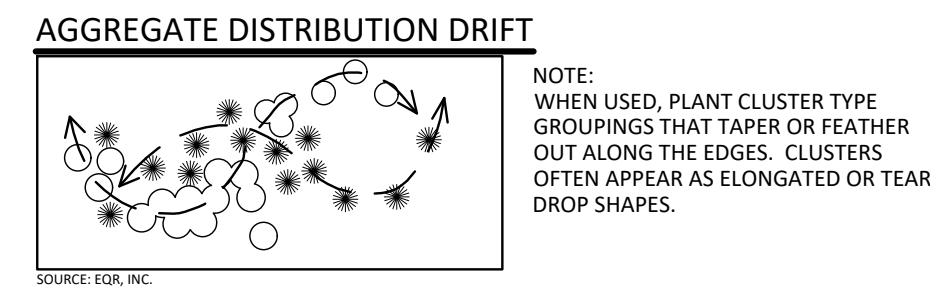
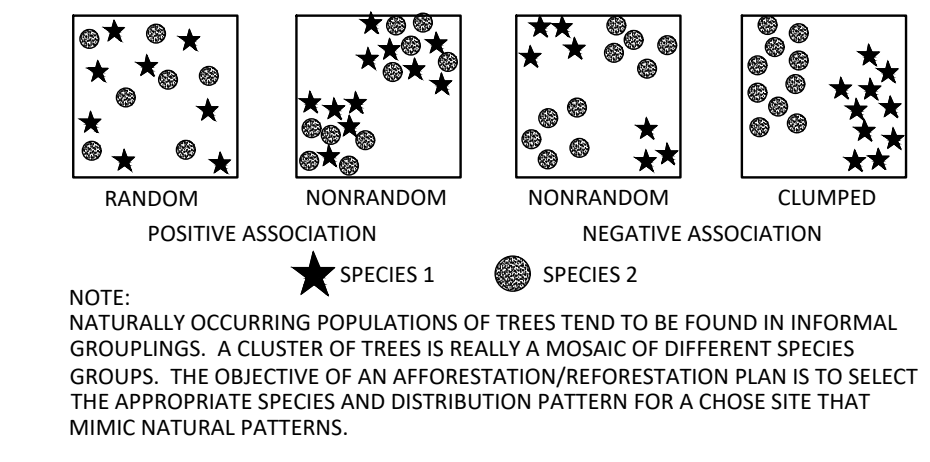

- NOTES:
1. ADAPTED FROM THE MARYLAND STATE FOREST CONSERVATION MANUAL, THIRD EDITION, 1997.

9 FOREST PLANTING DISTRIBUTION PATTERN NOT TO SCALE

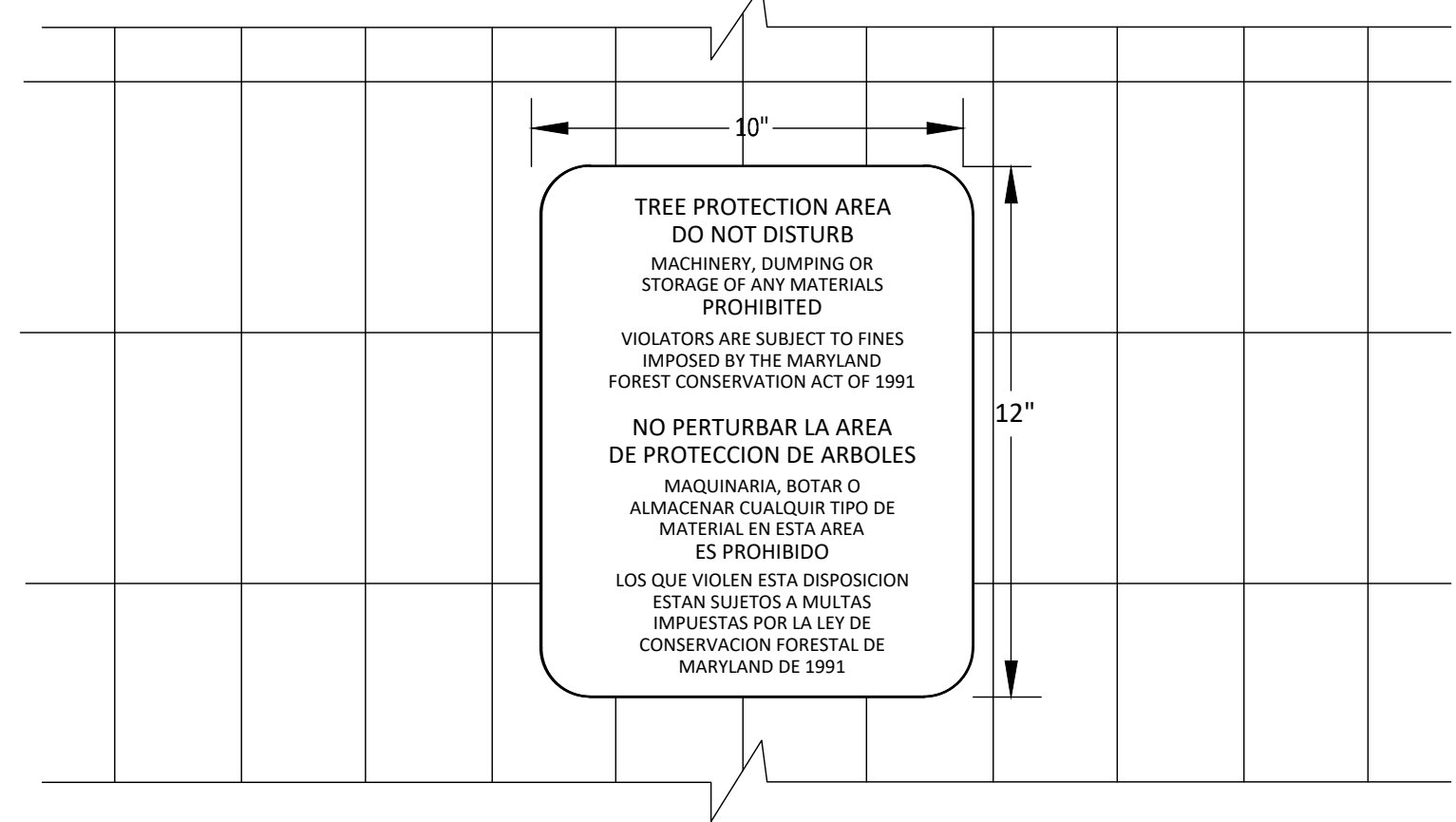

- NOTES:
1. SIGNS MUST BE WATERPROOF.
2. SIGNS MUST BE IN ENGLISH AND SPANISH.
3. SIGNS TO BE ATTACHED TO THE TREE PROTECTION FENCE.
4. SIGNS TO BE PLACED APPROXIMATELY 30' APART AND AT FENCE CORNERS, OR AS DIRECTED BY THE FOREST CONSERVATION (FC) INSPECTOR. CONDITIONS ON SITE AFFECTING VISIBILITY MAY WARRANT PLACING SIGNS CLOSER OR FURTHER APART.
5. ATTACHMENT OF SIGNS TO TREES IS PROHIBITED.
6. SEE CONSTRUCTION TREE PROTECTION FENCE DETAIL THIS SHEET.
7. ADAPTED FROM MONTGOMERY COUNTY M-NCPPC PLANNING DEPARTMENT.

2 CONSTRUCTION TREE PROTECTION FENCE SIGN DETAIL NOT TO SCALE

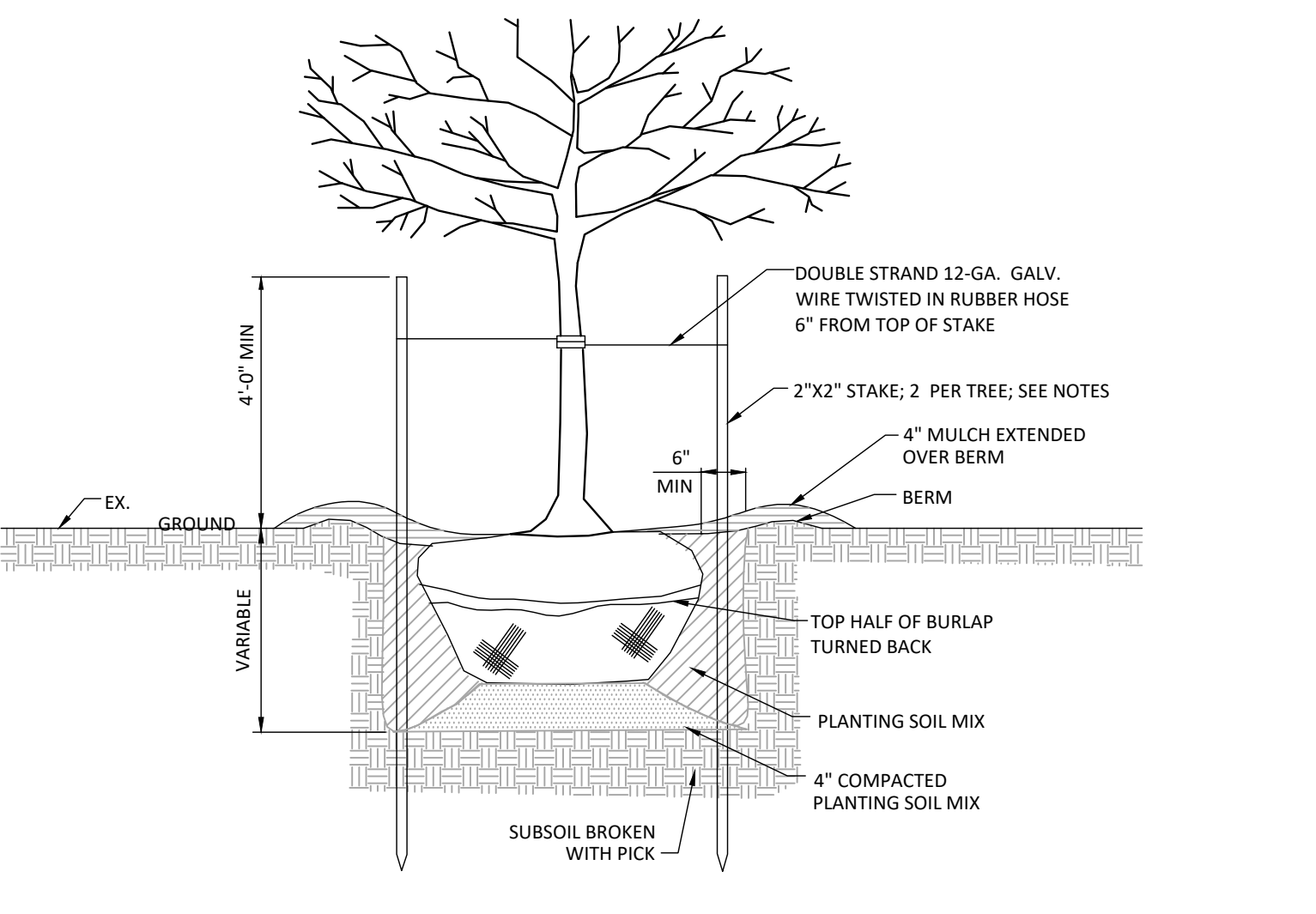

- NOTES:
1. STAKE TREES ONLY IN AREAS OF HIGH WIND. REMOVE STAKING AFTER FIRST GROWING SEASON.
2. STAKING SHOWN ON THIS DETAIL IS FOR DECIDUOUS AND EVERGREEN TREES UNDER 4" CALIPER AND 6' OR MORE IN HEIGHT.
3. LANDSCAPE TREES FOR FOREST CONSERVATION CREDIT ARE PLANTED PER THE LANDSCAPE PLAN. REFER TO THE LANDSCAPE PLAN FOR ALL PLANTING DETAILS AND SPECIFICATIONS.

6 AFFORESTATION/REFORESTATION TREE PLANTING DETAIL NOT TO SCALE



- NOTES:
1. SEE THE AFFORESTATION/REFORESTATION TREE PROTECTION FENCE DETAIL THIS SHEET.
2. IF 14 GAUGE WIRE TREE PROTECTION FENCE IS PROPOSED AT AFFORESTATION/REFORESTATION AREA(S), SIGNS ARE TO BE PLACED APPROXIMATELY 30' APART. CONDITIONS ON SITE AFFECTING VISIBILITY MAY WARRANT PLACING SIGNS CLOSER OR FURTHER APART.
3. ON THREE BOARD RAIL TREE PROTECTION FENCE, SIGNS ARE TO BE ATTACHED TO THE POST FACING EVERY 6TH POST OR 48" OR AS DETERMINED BY THE FOREST INSPECTOR.
4. BOTTOM OF SIGNS TO BE HIGHER THAN TOP OF TREE PROTECTION FENCE.
5. ATTACHMENT OF SIGNS TO TREES IS PROHIBITED.
6. SIGNS SHALL BE MAINTAINED THROUGHOUT THE AFFORESTATION/REFORESTATION MAINTENANCE AND MANAGEMENT PERIOD. DO NOT REMOVE WITHOUT APPROVAL OF THE FOREST CONSERVATION INSPECTOR.
7. ADAPTED FROM MONTGOMERY COUNTY M-NCPPC PLANNING DEPARTMENT.

3 AFFORESTATION/REFORESTATION TREE PROTECTION FENCE SIGN DETAIL NOT TO SCALE

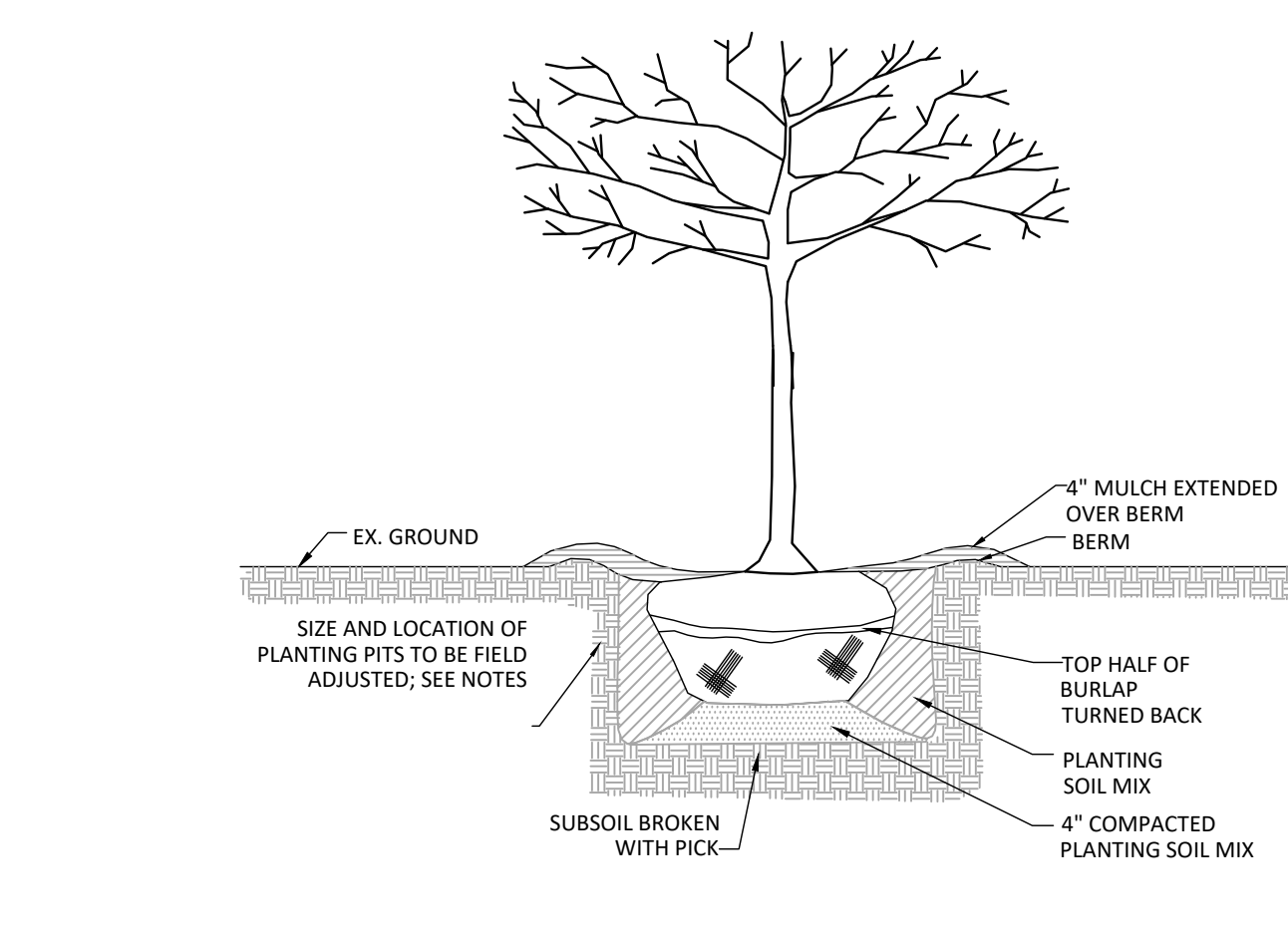

- NOTES:
1. DIGGING OF TREE PITS IN THE CRITICAL ROOT ZONE (CRZ) OF EXISTING TREES AND/OR IN FOREST CONSERVATION EASEMENT AREAS IS RESTRICTED TO HAND EQUIPMENT ONLY TO PROTECT ADJACENT SAVED TREES.
2. STANDARD PLANTING TECHNIQUE IS TO DIG A SHRUB PIT THAT IS 2.5 TIMES THE SIZE OF THE ROOTBALL. HOWEVER, THE SIZE OF PLANTING PITS IS TO BE LIMITED AND THE LOCATION OF THE PITS FIELD ADJUSTED WITHIN THE CRZ'S OF SAVED TREES IN ORDER TO PROTECT ROOTS OF THE ADJACENT SAVED TREES THAT ARE 2" OR GREATER IN SIZE.
3. STAKE TREES ONLY IN AREAS OF HIGH WIND. REMOVE STAKING AFTER FIRST GROWING SEASON.
4. LANDSCAPE TREES FOR FOREST CONSERVATION CREDIT ARE PLANTED PER THE LANDSCAPE PLAN. REFER TO THE LANDSCAPE PLAN FOR ALL PLANTING DETAILS AND SPECIFICATIONS.

7 AFFORESTATION/REFORESTATION SHRUB PLANTING DETAIL NOT TO SCALE

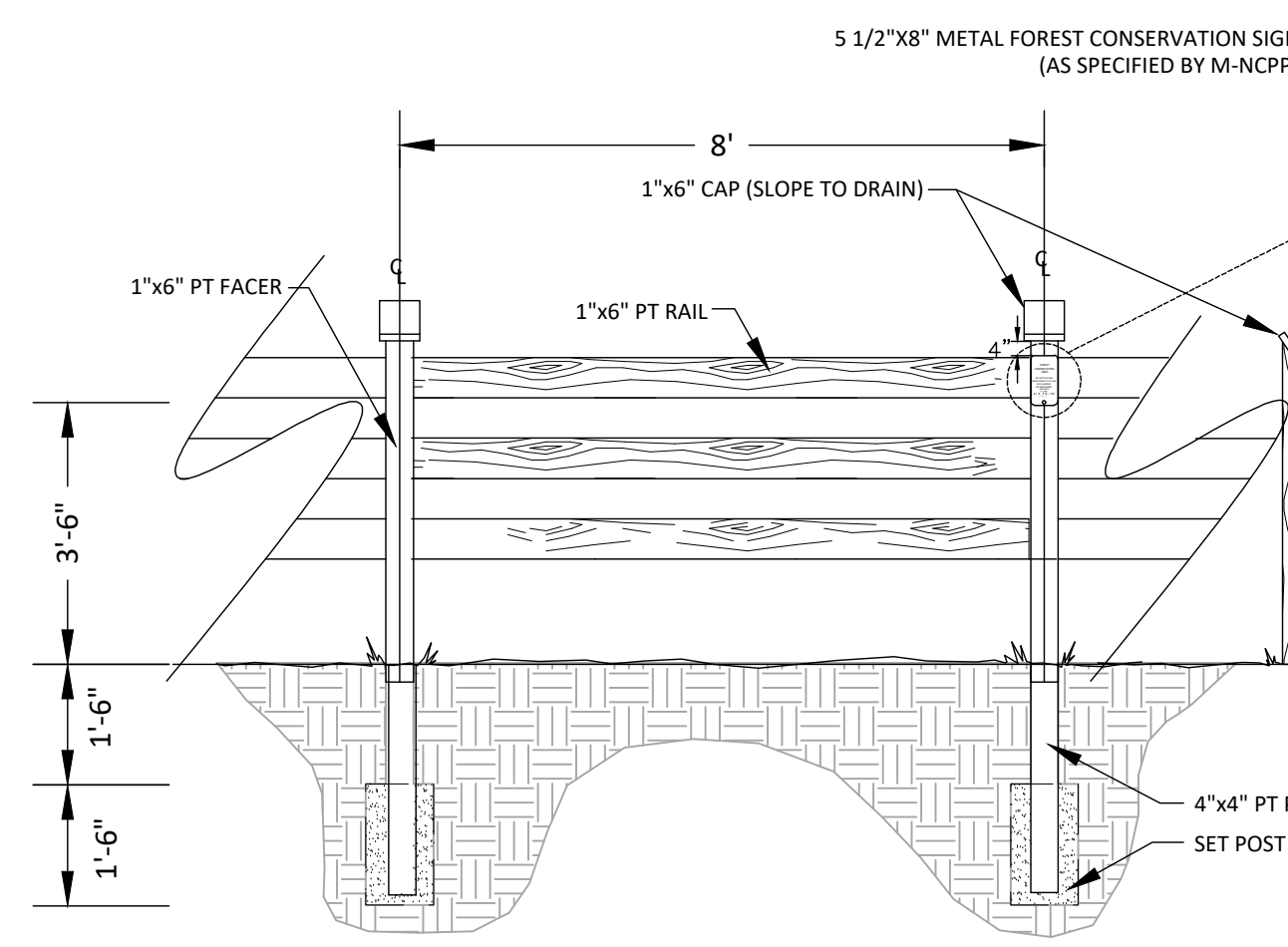

- NOTES:
1. ALL WOOD TO BE PRESSURE TREATED.
2. ALL HARDWARE TO BE GALVANIZED.
3. COLOR OF WOODEN FENCING TO BE DETERMINED BY OWNER.
4. ONE SIGN TO BE ATTACHED TO THE POST FACING EVERY 6TH POST OR 48" OR AS DETERMINED BY THE FOREST CONSERVATION (FC) INSPECTOR.
5. SEE AFFORESTATION/REFORESTATION TREE PROTECTION FENCE SIGN DETAIL THIS SHEET.
6. FENCE TO BE MAINTAINED THROUGHOUT MAINTENANCE AND MANAGEMENT AGREEMENT PERIOD. AFTER FINAL INSPECTION, WITH FC INSPECTOR APPROVAL, END USER MAY REMOVE FENCING OR LEAVE IT IN PLACE.

11 AFFORESTATION /REFORESTATION TREE PLANTING IN CRITICAL ROOT ZONES OF EXISTING TREES DETAIL NOT TO SCALE

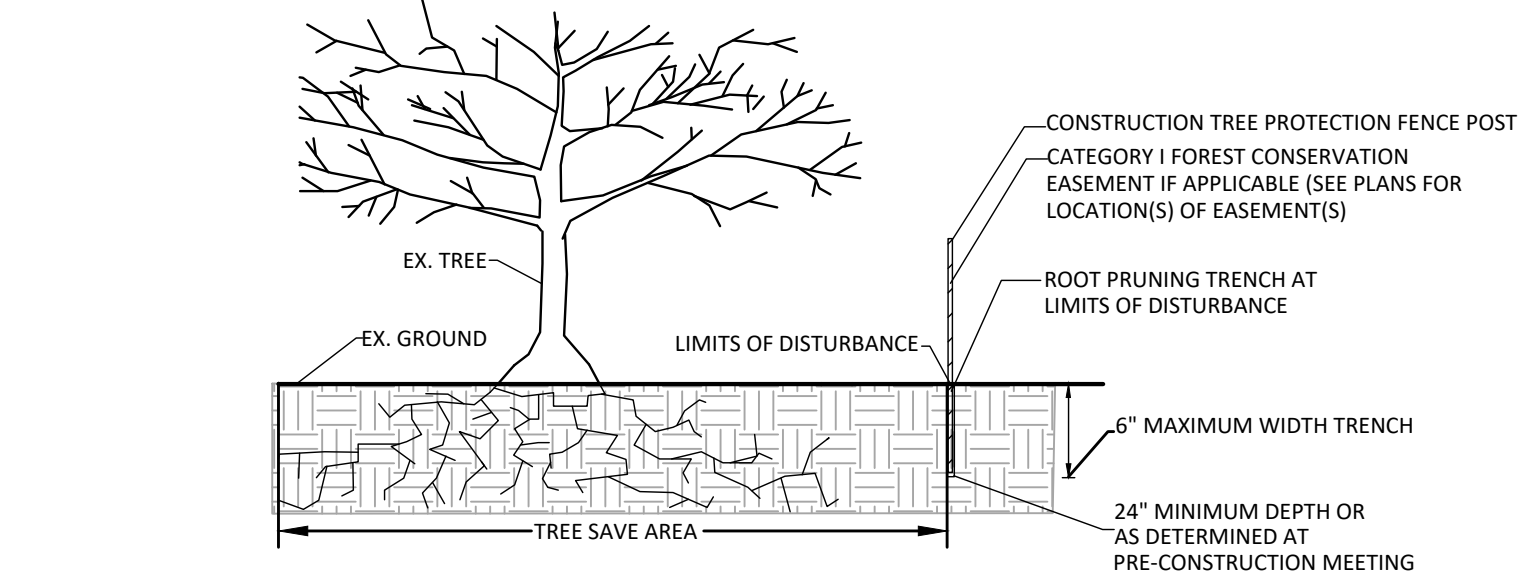

- NOTES:
1. RETENTION AREAS TO BE ESTABLISHED AS PART OF THE FOREST CONSERVATION PLAN REVIEW PROCESS AND PRE-CONSTRUCTION MEETING.
2. BOUNDARIES OF RETENTION AREAS MUST BE STAKED AT THE PRE-CONSTRUCTION MEETING AND FLAGGED, PRIOR TO TRENCHING.
3. EXACT LOCATION OF TRENCH SHOULD BE DETERMINED IN THE FIELD IN COORDINATION WITH THE FOREST CONSERVATION (FC) INSPECTOR.
4. TRENCH SHOULD BE IMMEDIATELY BACKFILLED WITH SOIL REMOVED OR ORGANIC SOIL AS SPECIFIED PER THE PLAN OR BY THE FC INSPECTOR.
5. ROOTS SHOULD BE CLEANLY CUT USING VIBRATORY KNIFE OR OTHER ACCEPTABLE EQUIPMENT.
6. ALL ROOT PRUNING TO BE PERFORMED BY AN ISA CERTIFIED ARBORIST WHO IS ALSO A LICENSED MARYLAND TREE EXPERT IN COORDINATION WITH THE FOREST CONSERVATION INSPECTOR. SEE THE CONSTRUCTION TREE PROTECTION FENCING DETAIL THIS SHEET.
7. ADAPTED FROM MONTGOMERY COUNTY M-NCPPC PLANNING DEPARTMENT.

4 TREE ROOT PRUNING DETAIL NOT TO SCALE

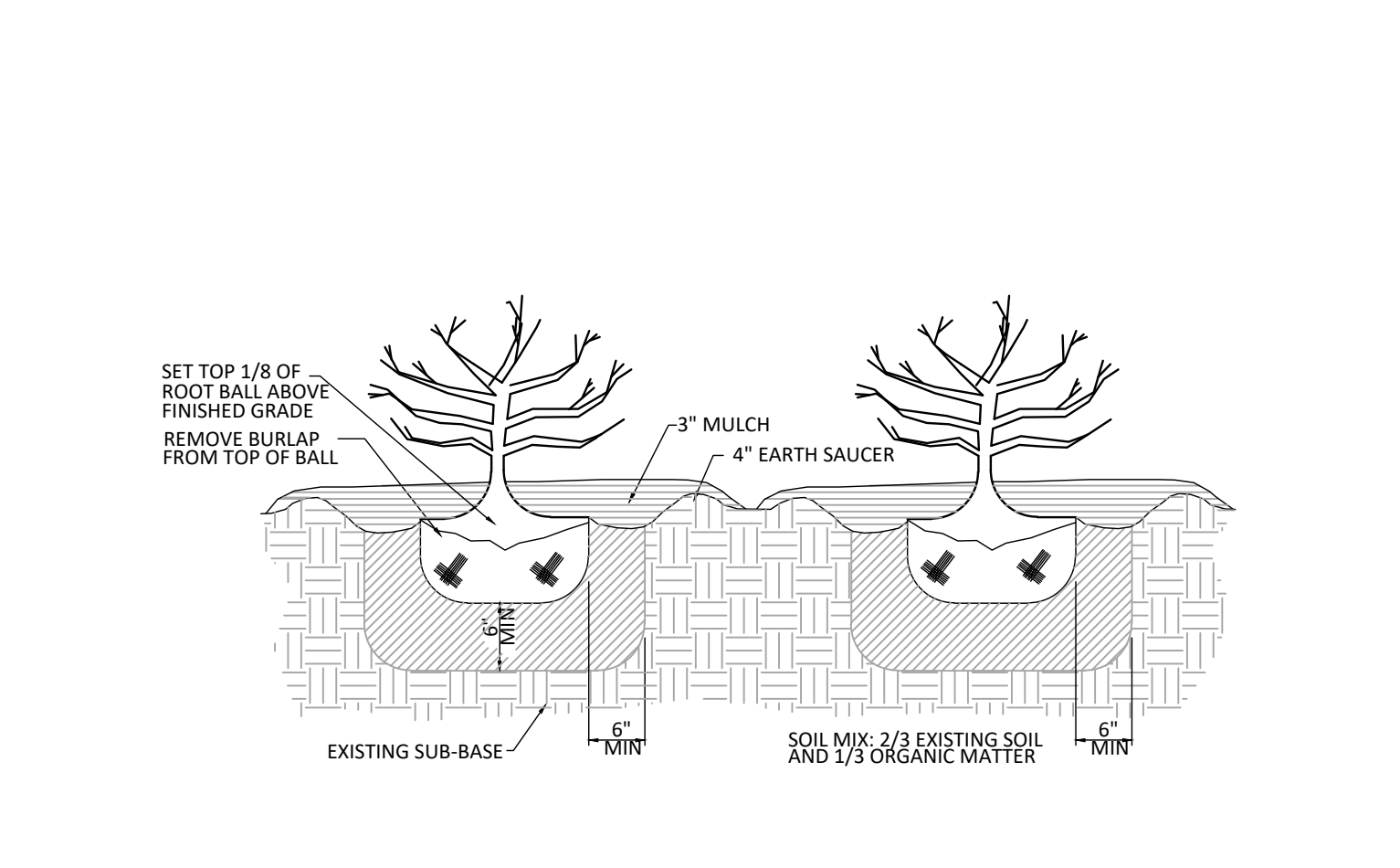

- NOTES:
1. DIGGING OF SHRUB PITS IN THE CRITICAL ROOT ZONE (CRZ) OF EXISTING TREES AND/OR IN FOREST CONSERVATION EASEMENT AREAS IS RESTRICTED TO HAND EQUIPMENT ONLY TO PROTECT ADJACENT SAVED SHRUBS AND TREES.
2. STANDARD PLANTING TECHNIQUE IS TO DIG A SHRUB PIT THAT IS 2.5 TIMES THE SIZE OF THE ROOTBALL. HOWEVER, THE SIZE OF PLANTING PITS IS TO BE LIMITED AND THE LOCATION OF THE PITS FIELD ADJUSTED WITHIN THE CRZ'S OF SAVED SHRUBS AND TREES IN ORDER TO PROTECT ROOTS OF THE ADJACENT SAVED SHRUBS AND TREES THAT ARE 1" OR GREATER IN SIZE.

8 AFFORESTATION/REFORESTATION SHRUB PLANTING DETAIL NOT TO SCALE

Table with columns REVISIONS and DATE.

16998 OVERHILL ROAD
4TH ELECTION DISTRICT
MONTGOMERY COUNTY, MARYLAND
WSSC GRID: 223NW07
TAX MAP:GT41

FINAL FOREST CONSERVATION PLAN DETAILS F20230100



DEVELOPER'S CERTIFICATE
The undersigned agrees to execute all the features of the Approved Final Forest Conservation Plan No. F20230100, including, financial bonding, forest planting, maintenance, and all other applicable agreements.
Developer's Name: Community Housing Initiative, Inc.
Contact Person or Owner: Patrick Byrne
Address: 1123 Ormond Court, McLean, VA 22101
Phone and Email: 703.556.9569, pbyrne@chidc.org
Signature: Patrick Byrne
DRAWN BY:
DESIGNED BY:
DATE ISSUED:
VKA PROJECT: VM50571
DRAWING NO:
SHEET NO: FFCP-201

"FOR LOCATION OF UTILITIES CALL 8-1-1 or 1-800-257-7777 OR LOG ON TO www.call811.com or http://www.msutility.net 48 HOURS IN ADVANCE OF ANY WORK IN THIS VICINITY"
The excavator must notify all public utility companies with underground facilities in the area of proposed excavation and have those facilities located by the utility companies before excavation. The excavator is responsible for compliance with requirements of Chapter 33A of the Montgomery County Code.



VIKA MARYLAND, LLC
20251 Century Blvd., Suite 400
Germantown, MD 20874
301.916.4100 | vika.com

Our Site Set on the Future.

PREPARED FOR:
COMMUNITY HOUSING
INITIATIVE, INC.
1123 ORMOND COURT
MCLEAN, VA 22101
CONTACT: PATRICK BYRNE
(703) 556-9569
pbyrne@chdc.org

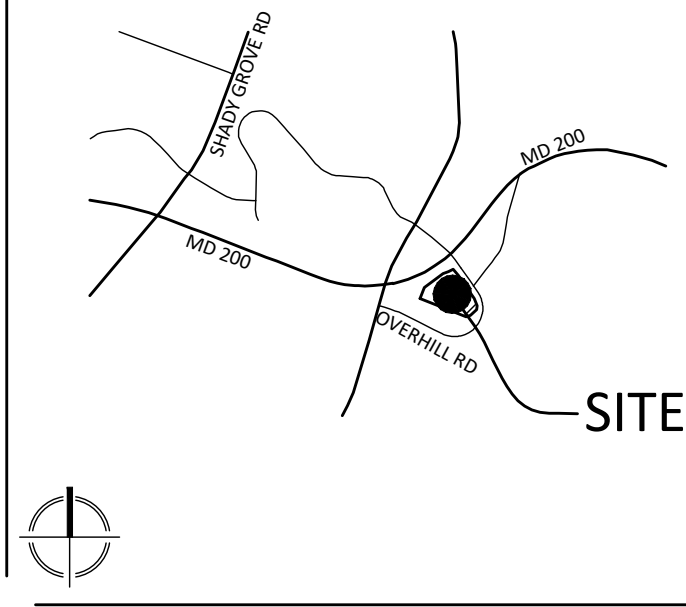

VICINITY MAP
SCALE: 1" = 2000'

PLANTING NARRATIVE FOR
AFFORESTATION/REFORESTATION AREAS

THIS PLANTING NARRATIVE IS FOR THE PLANTING OF AFFORESTATION AND/OR REFORESTATION AREAS ONLY. FOR SPECIFICATIONS AND DETAILS FOR THE PLANTING OF LANDSCAPE TREES FOR FOREST CONSERVATION CREDIT (20 YEAR CANOPY LANDSCAPE CREDIT OR SPECIMEN TREE MITIGATION CREDIT) SEE THE FINAL LANDSCAPE PLAN.

- 1. PRE-PLANTING CONSIDERATIONS
A. FOR PRE-PLANTING MEASURES TO BE TAKEN TO CONTROL INVASIVE SPECIES, SEE THE INVASIVE SPECIES MANAGEMENT PLAN THIS SHEET.
B. A SOILS ANALYSIS WILL BE CONDUCTED PRIOR TO COMMENCEMENT OF REFORESTATION. ON LAND WHERE EXTENSIVE AGRICULTURAL USE HAS OCCURRED IN THE PAST, TEST PITS WILL BE DUG IN AREAS OF UNDISTURBED SOIL TO DETERMINE IF A FRAGIPAN LAYER IS PRESENT. IF FRAGIPAN IS PRESENT, IT SHOULD BE PERCEIVED BY AUGURING AND PLANTING HOLES SHOULD BE DUG TO TWICE THE NORMAL DIAMETER FOR THE MATERIAL PLANTED.
C. SOILS SHOULD BE TREATED BY INCORPORATING NATURAL MULCH WITHIN THE TOP 12 INCHES, OR AMENDMENTS AS DETERMINED BY THE SOILS ANALYSIS. NATURAL AMENDMENTS, SUCH AS ORGANIC MULCH OR LEAF MOLD COMPOST ARE PREFERRED.
D. IF FILL MATERIAL IS USED AT THE PLANTING SITE, IT SHOULD BE CLEAN FILL WITH 12 INCHES OF NATIVE SOIL. STOCKPILING OF NATIVE TOP SOILS MUST BE DONE IN SUCH A WAY THAT THE HEIGHT OF THE PILE DOES NOT DAMAGE THE SEED BANK.

- 2. PLANT AMENDMENT MATERIAL STORAGE
IT IS RECOMMENDED THAT PLANTING OCCUR WITHIN 24 HOURS OF DELIVERY TO THE SITE. PLANT MATERIALS WHICH ARE LEFT UNPLANTED FOR MORE THAN 24 HOURS SHOULD BE PROTECTED FROM DIRECT SUN AND WEATHER AND KEPT MOIST. NURSERY STOCK SHOULD NOT BE LEFT UNPLANTED FOR MORE THAN TWO (2) WEEKS.
3. ON-SITE INSPECTION
PRIOR TO PLANTING, PLANTING STOCK SHOULD BE INSPECTED. PLANTS NOT CONFORMING TO STANDARD NURSERYMAN SPECIFICATIONS FOR SIZE, FORM, VIGOR, ROOTS, TRUNK WOUNDS, INSECTS, AND DISEASE SHOULD BE REPLACED.
4. PLANTING SPECIFICATIONS

- A. CONTAINER GROWN STOCK: SUCCESSFUL PLANTING OF CONTAINER GROWN STOCK REQUIRES CAREFUL SITE PREPARATION AND INSPECTION OF THE PLANT MATERIAL ROOT SYSTEM. CAUTION IS RECOMMENDED WHEN SELECTING PLANTS GROWN IN A SOILS MEDIUM DIFFERING FROM THAT OF THE PLANTING SITE. THE PLANT SHOULD BE REMOVED FROM THE CONTAINER AND THE ROOTS GENTLY LOOSENED FROM THE SOILS. IF THE ROOTS ENIRCLE THE ROOT BALL, SUBSTITUTION IS STRONGLY RECOMMENDED. J-SHAPED OR KINKED ROOT SYSTEMS SHOULD ALSO BE NOTED, AND SUBSTITUTED IF NECESSARY. ROOTS MAY NOT BE TRIMMED ON-SITE, DUE TO THE INCREASED CHANCES OF SOIL BORNE DISEASES. THE PLANTING FIELD SHOULD BE PREPARED AS SPECIFIED. NATIVE STOCKPILED SOILS SHOULD BE USED TO BACKFILL PLANTING FIELD. RAKE SOILS EVENLY OVER THE PLANTING FIELD AND COVER WITH 2 TO 4 INCHES OF MULCH.
B. BALLED AND BURLAPPED TREES: BALLED AND BURLAPPED TREES MUST BE HANDLED WITH CARE WHILE PLANTING. TREES SHOULD NOT BE PICKED UP BY THE TRUNK OR DROPPED. AS BOTH PRACTICES WILL TEND TO SEPARATE THE TRUNK FROM THE ROOT BALL. PRIOR TO PLANTING, ROOT BALLS SHOULD BE KEPT MOIST.
C. PLANTING FIELDS SHOULD BE CREATED EQUAL TO 2.5 TIMES THE DIAMETER OF THE ROOT BALL, UNLESS WITHIN THE CRITICAL ROOT ZONE OF EXISTING TREES. SEE DETAIL FOR PLANTING IN THE CRITICAL ROOT ZONE OF EXISTING TREES ON SHEET FFCP 500. USE WATERING TO SETTLE SOIL BACKFILLED AROUND TREES. STOCKPILED NATIVE TOP SOILS, IF AVAILABLE, SHOULD BE USED TO BACKFILL THE PLANTING FIELD. AMENDMENTS ARE NOT RECOMMENDED IN THE PLANTING FIELD AS STUDIES HAVE SHOWN THAT ROOTS WILL BE ENCOURAGED TO STAY WITHIN THE AMENDED SOILS. SOILS SHOULD BE RAKED EVENLY OVER THE PLANTING FIELD AND COVERED WITH 2 TO 4 INCHES OF MULCH.
D. STAKING OF TREES IS NOT RECOMMENDED EXCEPT IN AREAS OF HIGH WINDS. MOVEMENT IS NECESSARY TO STRENGTHEN THE TRUNK OF THE PLANTED TREE. IF STAKES ARE USED, THEY SHOULD BE REMOVED AFTER THE FIRST GROWING SEASON. WRAPPING IS ALSO NOT RECOMMENDED DUE TO THE INCREASED OPPORTUNITIES FOR INSECT INFESTATION AND DISEASE.

- 5. POST-PLANTING CONSIDERATIONS
A. SOIL STABILIZATION: FOR AREAS OF LARGE-SCALE DISTURBANCE, SOILS MUST BE STABILIZED USING A NON-TURF-BUILDING GROUND COVER OR ENGINEERING FABRIC.
B. PROTECTIVE DEVICES: TO PREVENT DAMAGE OF PLANTED AREAS, ALL REFORESTATION AND AFFORESTATION SITES MUST BE POSTED WITH APPROPRIATE SIGNS AND FENCED. CONSTRUCTION EQUIPMENT SHALL BE PROHIBITED IN THESE AREAS. SEE FINAL FOREST CONSERVATION NOTES 6 AND 7 THIS SHEET.

FIVE YEAR AFFORESTATION/ REFORESTATION
MANAGEMENT PLAN

- YEAR 1:
A. INITIAL INVASIVE SPECIES MANAGEMENT ACTIVITIES SHOULD BE IMPLEMENTED PRIOR TO PREPARING AREAS FOR PLANTING AS PER THE INVASIVE SPECIES MANAGEMENT PLAN THIS SHEET.
B. AREAS ARE PLANTED ACCORDING TO PRE-APPROVED PLAN.
C. SURVIVAL CHECK 3 TIMES (MARCH-APRIL), (JULY-AUGUST), (OCTOBER-NOVEMBER).
D. FERTILIZATION AND WATERING AS NEEDED.
E. CONTROL OF UNDESIRABLE VEGETATION AS PER THE INVASIVE SPECIES MANAGEMENT PLAN.
F. DOCUMENTATION OF EACH MAINTENANCE VISIT IS TO BE PROVIDED TO THE CLIENT AND THE FOREST CONSERVATION FC INSPECTOR.
G. ANNUAL INSPECTION BY M-NCPPC FC INSPECTOR.

- YEAR 2:
A. REINFORCEMENT PLANTING IF NEEDED.
B. SURVIVAL CHECK ONCE ANNUALLY (MAY-SEPTEMBER).
C. WATERING AS NEEDED.
D. CONTROL OF UNDESIRABLE VEGETATION AS PER THE INVASIVE SPECIES MANAGEMENT PLAN.
E. DOCUMENTATION OF EACH MAINTENANCE VISIT IS TO BE PROVIDED TO THE CLIENT AND THE FC INSPECTOR.
F. ANNUAL INSPECTION BY M-NCPPC FC INSPECTOR.

- YEARS 3-5:
A. CONTROL OF UNDESIRABLE VEGETATION AS PER THE INVASIVE SPECIES MANAGEMENT PLAN.
B. DOCUMENTATION OF EACH MAINTENANCE VISIT IS TO BE PROVIDED TO THE CLIENT AND THE FC INSPECTOR.
C. ANNUAL INSPECTION BY M-NCPPC FC INSPECTOR.

FERTILIZATION OR WATERING DURING YEAR 1 WILL BE DONE ON AN AS NEEDED BASIS. DOCUMENTATION OF MAINTENANCE VISITS AND CONDITION CHECK SHEETS SHOULD BE PROVIDED TO THE CLIENT AND THE FC INSPECTOR AFTER EACH VISIT. A SURVIVAL RATE OF 75% IS REQUIRED AFTER 5 YEARS. IF ADEQUATE NATURAL REGENERATION HAS OCCURRED, IT MAY BE INCLUDED IN THE FINAL SURVIVAL TALLY. SPECIAL RETURN OPERATIONS OR RECOMMENDATIONS WILL BE CONDUCTED ON AN AS NEEDED BASIS. PERMETER FENCING AND SIGNAGE MAY BE REMOVED AFTER YEAR 5 WITH FORMAL ACCEPTANCE OF THE PLANT MATERIAL BY THE FC INSPECTOR AND APPROVAL TO REMOVE THE FENCING. PERMANENT FOREST CONSERVATION EASEMENT BOUNDARY MARKERS ARE TO REMAIN.

AT THE END OF THE FIVE-YEAR MANAGEMENT PLAN, A FINAL INSPECTION MEETING WILL BE HELD TO INCLUDE THE CONTRACT ARBORIST, M-NCPPC INSPECTOR, AND OWNER'S REPRESENTATIVE AND ANY FINAL WORK REQUIRED TO COMPLETE THE PROGRAM, IF ANY, WILL BE IDENTIFIED AND MUST BE COMPLETED WITHIN THE TIMEFRAME REQUIRED BY THE FC INSPECTOR.

FIVE YEAR INVASIVE SPECIES MANAGEMENT PLAN

THIS INVASIVE SPECIES MANAGEMENT PLAN FOR AFFORESTATION AREAS 1 & 2 FOR WHICH THIS FFCP IS SUBMITTED. A FIVE-YEAR PLAN IS PROPOSED TO ERADICATE INVASIVE AS IDENTIFIED AND MARKED FOR REMOVAL BY THE ISA CERTIFIED ARBORIST.

IDENTIFICATION AND PROTECTION OF EXISTING NATIVE PLANTS IS A KEY COMPONENT OF ANY INVASIVE SPECIES MANAGEMENT PROGRAM. CARE MUST BE TAKEN TO AVOID CONTACT OF HERBICIDES WITH DESIRED DESIRABLE TREES, SHRUBS, TUNE GRASSES OR OTHER DESIRABLE VEGETATION SINCE DAMAGE CAN RESULT FROM THEIR USE. ALL WORK SHALL BE PERFORMED UNDER THE SUPERVISION OF AN ISA CERTIFIED ARBORIST WHO IDENTIFIES AND MARKS INVASIVE PLANTS. WORK BOUNDARIES SHOULD BE ESTABLISHED WHERE ADJOINING FIELDS OR WOODLAND NOT TARGETED FOR INVASIVE SPECIES CONTROL ARE LOCATED. APPLICATION OF ANY HERBICIDES CAN ONLY BE PERFORMED BY A LICENSED PESTICIDE APPLICATOR. APPLICATOR'S LICENSE NUMBER MUST BE INCLUDED IN ANY REPORTS DOCUMENTING THEIR USE. PERSONAL PROTECTION EQUIPMENT USED BY THE APPLICATOR(S) MUST FOLLOW STATE AND LABEL GUIDELINES.

- YEARS ONE THROUGH FIVE:
GENERAL INVASIVE MANAGEMENT ACTIVITIES WILL OCCUR A MINIMUM OF TWO TIMES DURING THE GROWING SEASON IN THE TARGETED AREAS WHERE THE INVASIVE PLANTS ARE EVIDENT.
1. IN THE SPRING, CUT THE STEMS OF THE INVASIVE PLANTS, AS IDENTIFIED BY THE ARBORIST, LOW TO THE GROUND AND TREAT REMAINING PLANT STEMS WITH GLYPHOSATE.
2. IN THE FALL, CUT THE STEMS OF THE INVASIVE PLANTS, AS IDENTIFIED BY THE ARBORIST, LOW TO THE GROUND AND TREAT REMAINING STEMS WITH GLYPHOSATE.
3. AFTER EACH APPLICATION/TREATMENT A BRIEF REPORT DOCUMENTING THE SPECIES TREATED, AREA OF TREATMENT, MATERIAL AND/OR METHOD USED AND DATES OF APPLICATION WILL BE SUBMITTED TO THE M-NCPPC INSPECTOR.

AN ANNUAL REPORT WILL BE SUBMITTED TO THE M-NCPPC FOREST INSPECTOR AT THE END OF EACH YEAR OF THE PROGRAM, WITH A SUMMARY OF INVASIVE TREATMENT MEASURES. AT THE END OF THE FIVE-YEAR MANAGEMENT PLAN, A FINAL INSPECTION MEETING WILL BE HELD TO INCLUDE THE CONTRACT ARBORIST, M-NCPPC INSPECTOR, AND OWNER'S REPRESENTATIVE AND ANY FINAL WORK REQUIRED TO COMPLETE THE PROGRAM, IF ANY, WILL BE IDENTIFIED.

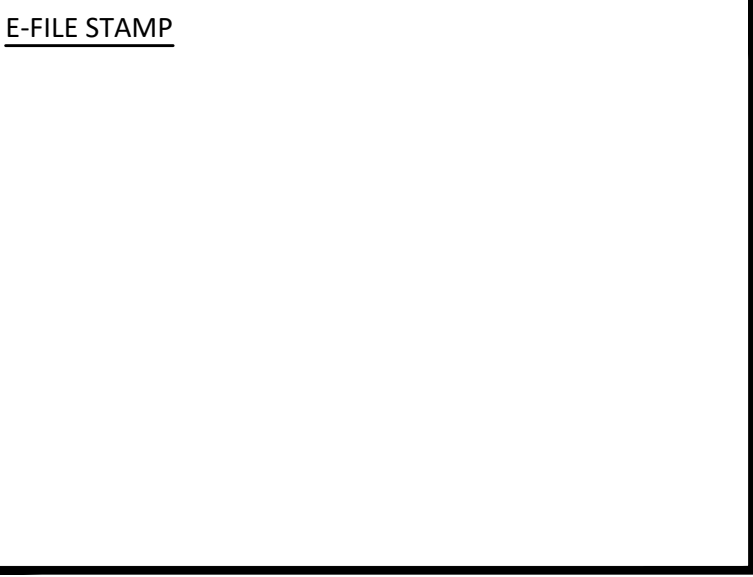

FINAL FOREST CONSERVATION NOTES

SEQUENCE OF EVENTS FOR PROPERTIES REQUIRED TO COMPLY WITH FOREST CONSERVATION PLANS, EXEMPTIONS FROM SUBMITTING FOREST CONSERVATION PLANS, AND TREE SAVE PLANS (M-NCPPC MC PLANNING DEPARTMENT MARCH, 2017)

THE PROPERTY OWNER IS RESPONSIBLE FOR ENSURING ALL TREE PROTECTION MEASURES ARE PERFORMED IN ACCORDANCE WITH THE APPROVED FINAL FOREST CONSERVATION PLAN OR TREE SAVE PLAN, AND AS MODIFIED IN THE FIELD BY A PLANNING DEPARTMENT FOREST CONSERVATION INSPECTOR. THE MEASURES MUST MEET OR EXCEED THE MOST RECENT STANDARDS PUBLISHED BY THE AMERICAN NATIONAL STANDARDS INSTITUTE (ANSI A300).

- PRE-CONSTRUCTION
1. AN ON-SITE PRE-CONSTRUCTION MEETING IS REQUIRED AFTER THE LIMITS OF DISTURBANCE HAVE BEEN STAKED AND FLAGGED AND BEFORE ANY LAND DISTURBANCE.

- 2. THE PROPERTY OWNER MUST ARRANGE FOR THE MEETING AND THE FOLLOWING PEOPLE MUST PARTICIPATE AT THE PRE-CONSTRUCTION MEETING: THE PROPERTY OWNER OR THEIR REPRESENTATIVE, CONSTRUCTION SUPERINTENDENT, INTERNATIONAL SOCIETY OF ARBORICULTURE (ISA) CERTIFIED ARBORIST/MARYLAND LICENSED TREE EXPERT REPRESENTING OWNER THAT WILL IMPLEMENT THE TREE PROTECTION MEASURES, THE PLANNING DEPARTMENT FOREST CONSERVATION INSPECTOR, AND MONTGOMERY COUNTY DEPARTMENT OF PLANNING SERVICES (DPS) SEDIMENT CONTROL INSPECTOR. THE PURPOSE OF THIS MEETING IS TO VERIFY THE LIMITS OF DISTURBANCE AND DISCUSS SPECIFIC TREE PROTECTION AND TREE CARE MEASURES SHOWN ON THE APPROVED PLAN. NO LAND DISTURBANCE SHALL BEGIN BEFORE TREE PROTECTION AND STRESS-REDUCTION MEASURES HAVE BEEN IMPLEMENTED AND APPROVED BY THE PLANNING DEPARTMENT'S FOREST CONSERVATION INSPECTOR.

- a. TYPICAL TREE PROTECTION DEVICES INCLUDE:
i. CHAIN LINK FENCE (FOUR FEET HIGH)
ii. SUPER SILT FENCE WITH WIRE STRUNG BETWEEN THE SUPPORT POLES (MINIMUM 4 FEET HIGH) WITH HIGH VISIBILITY FLAGGING.
iii. 14 GAUGE, 2 INCH X 4 INCH WELDED WIRE FENCING SUPPORTED BY STEEL T-BAR POSTS (MINIMUM 4 FEET HIGH) WITH HIGH VISIBILITY FLAGGING.
b. TYPICAL STRESS REDUCTION MEASURES MAY INCLUDE, BUT ARE NOT LIMITED TO:
i. ROOT PRUNING WITH A ROOT CUTTER OR VIBRATORY FLOW DESIGNED FOR THAT PURPOSE. TRENCHERS ARE NOT ALLOWED, UNLESS APPROVED BY THE FOREST CONSERVATION INSPECTOR.
ii. CROWN REDUCTION OR PRUNING
iii. WATERING
iv. FERTILIZING
v. VERTICAL MULCHING
vi. ROOT AERATION SYSTEMS

MEASURES NOT SPECIFIED ON THE FOREST CONSERVATION PLAN MAY BE REQUIRED AS DETERMINED BY THE FOREST CONSERVATION INSPECTOR IN COORDINATION WITH THE PROPERTY OWNER'S ARBORIST.

- 3. A MARYLAND LICENSED TREE EXPERT MUST PERFORM, OR DIRECTLY SUPERVISE, THE IMPLEMENTATION OF ALL STRESS REDUCTION MEASURES. DOCUMENTATION OF THE PROCESS (INCLUDING PHOTOGRAPHS) MAY BE REQUIRED BY THE FOREST CONSERVATION INSPECTOR, AND WILL BE DETERMINED AT THE PRE-CONSTRUCTION MEETING.

- 4. TEMPORARY TREE PROTECTION DEVICES MUST BE INSTALLED PER THE APPROVED FOREST CONSERVATION PLAN, EXEMPTION PLAN, OR TREE SAVE PLAN AND PRIOR TO ANY LAND DISTURBANCE. THE FOREST CONSERVATION INSPECTOR, IN COORDINATION WITH THE DPS SEDIMENT CONTROL INSPECTOR, MAY MAKE FIELD ADJUSTMENTS TO INCREASE THE SURVIVABILITY OF TREES AND FOREST SHOWN AS SAVED ON THE APPROVED PLAN.

- 5. TREE PROTECTION FENCING MUST BE INSTALLED AND MAINTAINED BY THE PROPERTY OWNER FOR THE DURATION OF CONSTRUCTION PROJECT AND MUST NOT BE ALTERED WITHOUT PRIOR APPROVAL FROM THE FOREST CONSERVATION INSPECTOR. ALL CONSTRUCTION ACTIVITY WITHIN PROTECTED TREE AND FOREST AREAS IS PROHIBITED. THIS INCLUDES THE FOLLOWING ACTIVITIES:
a. PARKING OR DRIVING OF EQUIPMENT, MACHINERY OR VEHICLES OF ANY TYPE.
b. STORAGE OF ANY CONSTRUCTION MATERIALS, EQUIPMENT, STOCKPILING, FILL, DEBRIS, ETC.
c. DUMPING OF ANY CHEMICALS (I.E., PAINT THINNERS, MOTOR OIL OR CONCRETE REMAINERS), TRASH, GARBAGE, OR DEBRIS OF ANY KIND.
d. FELLING OF TREES INTO A PROTECTED AREA.
e. TRENCHING OR GRADING FOR UTILITIES, IRRIGATION, DRAINAGE, ETC.

- 6. FOREST AND TREE PROTECTION SIGNS MUST BE INSTALLED AS REQUIRED BY THE FOREST CONSERVATION INSPECTOR. THE SIGNS MUST BE WATERPROOF AND WORDING PROVIDED IN BOTH ENGLISH AND SPANISH.

DURING CONSTRUCTION

- 7. PERIODIC INSPECTIONS WILL BE MADE BY THE FOREST CONSERVATION INSPECTOR. CORRECTIONS AND REPAIRS TO TREE PROTECTION DEVICES MUST BE COMPLETED WITHIN THE TIMEFRAME GIVEN BY THE INSPECTOR.

- 8. THE PROPERTY OWNER MUST IMMEDIATELY NOTIFY THE FOREST CONSERVATION INSPECTOR OF ANY DAMAGE TO TREES, FORESTS, UNDERSTORY, GROUND COVER, AND ANY OTHER UNDISTURBED AREAS SHOWN ON THE APPROVED PLAN. REMEDIAL ACTIONS, AND THE RELATIVE TIMEFRAMES TO RESTORE THESE AREAS, WILL BE DETERMINED BY THE FOREST CONSERVATION INSPECTOR.

POST-CONSTRUCTION

- 9. AFTER CONSTRUCTION IS COMPLETED, BUT BEFORE TREE PROTECTION DEVICES HAVE BEEN REMOVED, THE PROPERTY OWNER MUST REQUEST A FINAL INSPECTION WITH THE FOREST CONSERVATION INSPECTOR. AT THE FINAL INSPECTION, THE FOREST CONSERVATION INSPECTOR MAY REQUIRE ADDITIONAL CORRECTIVE MEASURES, WHICH MAY INCLUDE:
a. REMOVAL AND POSSIBLE REPLACEMENT OF DEAD, DYING, OR HAZARDOUS TREES
b. PRUNING OF DEAD OR DECLINING LIMBS
c. SOIL AERATION
d. FERTILIZATION
e. WATERING
f. WOUND REPAIR
g. CLEAN UP OF RETENTION AREAS, INCLUDING TRASH REMOVAL.

- 10. AFTER THE FINAL INSPECTION AND COMPLETION OF ALL CORRECTIVE MEASURES THE FOREST CONSERVATION INSPECTOR WILL REQUEST ALL TEMPORARY TREE AND FOREST PROTECTION DEVICES BE REMOVED FROM THE SITE. REMOVAL OF TREE PROTECTION DEVICES THAT ALSO OPERATE FOR EROSION AND SEDIMENT CONTROL MUST BE COORDINATED WITH BOTH DPS AND THE FOREST CONSERVATION INSPECTOR AND CANNOT BE REMOVED WITHOUT PERMISSION OF THE FOREST CONSERVATION INSPECTOR. NO ADDITIONAL GRADING, SOILING, OR BURNAL MAY TAKE PLACE AFTER THE TREE PROTECTION FENCING IS REMOVED.

- 11. LONG-TERM PROTECTION MEASURES, INCLUDING PERMANENT DAMAGE, MUST BE INSTALLED PER THE APPROVED PLAN. INSTALLATION WILL OCCUR AT THE APPROPRIATE TIME DURING THE CONSTRUCTION PROJECT. REFER TO THE APPROVED PLAN DRAWING FOR THE LONG-TERM PROTECTION MEASURES TO BE INSTALLED.

INSPECTIONS

ALL FIELD INSPECTIONS MUST BE REQUESTED BY THE APPLICANT.

FIELD INSPECTIONS MUST BE CONDUCTED AS FOLLOWS:

TREE SAVE PLANS AND FOREST CONSERVATION PLANS WITHOUT PLANTING REQUIREMENTS

- 1. AFTER THE LIMITS OF DISTURBANCE HAVE BEEN STAKED AND FLAGGED, BUT BEFORE ANY CLEARING OR GRADING BEGINS.
2. AFTER NECESSARY STRESS REDUCTION MEASURES HAVE BEEN COMPLETED AND PROTECTION MEASURES HAVE BEEN INSTALLED, BUT BEFORE ANY CLEARING AND GRADING BEGIN AND BEFORE RELEASE OF THE BUILDING PERMIT.
3. AFTER COMPLETION OF ALL CONSTRUCTION ACTIVITIES, BUT BEFORE REMOVAL OF TREE PROTECTION FENCING, TO DETERMINE THE LEVEL OF COMPLIANCE WITH THE PROVISIONS OF THE FOREST CONSERVATION.

ADDITIONAL REQUIREMENTS FOR PLANS WITH PLANTING REQUIREMENTS

- 4. BEFORE THE START OF ANY REQUIRED REFORESTATION AND AFFORESTATION PLANTING.
5. AFTER THE REQUIRED REFORESTATION AND AFFORESTATION PLANTING HAS BEEN COMPLETED TO VERIFY THAT THE PLANTING IS ACCEPTABLE AND PRIOR TO THE START OF THE MAINTENANCE PERIOD.
6. AT THE END OF THE MAINTENANCE PERIOD TO DETERMINE THE LEVEL OF COMPLIANCE WITH THE PROVISIONS OF THE PLANTING PLAN, AND, IF APPROPRIATE, RELEASE OF THE PERFORMANCE BOND.

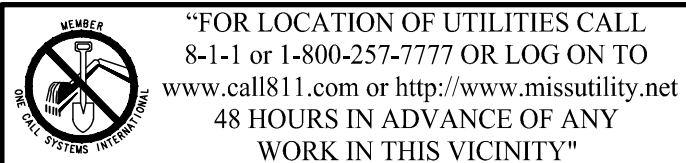

The excavator must notify all public utility companies with underground facilities in the area of proposed excavation and have those facilities located by the utility companies prior to commencing excavation. The excavator is responsible for compliance with requirements of Chapter 53a of the Montgomery County Code.

Table with 2 columns: REVISIONS, DATE. Multiple empty rows for tracking changes.

16998
OVERHILL
ROAD
4TH ELECTION DISTRICT
MONTGOMERY COUNTY,
MARYLAND
WSSC GRID: 223NW07
TAX MAP:GT41

FINAL
FOREST
CONSERVATION
PLAN
NOTES &
SCHEDULES
F20230100

PROFESSIONAL SEAL

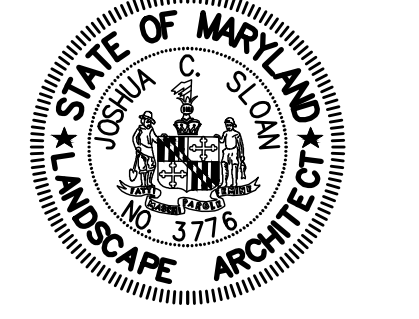

I HEREBY CERTIFY THAT THESE DOCUMENTS WERE PREPARED OR APPROVED BY ME AND THAT I AM A LICENSED PROFESSIONAL ARCHITECT UNDER THE LAWS OF THE STATE OF MARYLAND.
PATRICK BYRNE, LICENSE NO. 3775
V.M.S. LICENSE NUMBER 3775 EXP. DATE: MAY 31, 2022

THE INFORMATION, DESIGN AND CONTENT OF THESE DRAWINGS OR DOCUMENTS ARE PROPRIETARY TO VIKA MARYLAND, LLC AND CONSTITUTE ITS PROPRIETARY INTELLECTUAL PROPERTY. THESE DRAWINGS AND/OR DOCUMENTS MAY BE REPRODUCED, COPIED, OR OTHERWISE COPIED, DIGITALLY CONVERTED, MODIFIED OR USED FOR ANY PURPOSE, IN ANY FORMAT, WITHOUT PRIOR WRITTEN AUTHORIZATION FROM VIKA MARYLAND, LLC. VIOLATION MAY RESULT IN PROSECUTION. ONLY APPROVED, SIGNED AND SEALED PLANS OR DRAWINGS MAY BE UTILIZED FOR CONSTRUCTION PURPOSES.

© 2019 VIKA MARYLAND, LLC
DRAWN BY: _____
DESIGNED BY: _____
DATE ISSUED: _____

VIKA
PROJECT VMS0571
DRAWING
NO. _____

SHEET NO. FFCP-202

DEVELOPER'S CERTIFICATE
The undersigned agrees to execute all the features of the Approved Final Forest Conservation Plan No. _____ including, financial bonding, forest planting, maintenance, and all other applicable agreements.
Developer's Name: Community Housing Initiative, Inc.
Contact Person or Owner: Patrick Byrne
Address: 1123 Ormond Court, McLean, VA 22101
Phone and Email: 703.556.9569 pbyrne@chdc.org
Signature: _____

PLAN LEGEND

-CIV	PROPERTY LINES	8" W	PROPOSED WATER LINE	EXISTING GUY POLE	* 8.0'	EXISTING BOLLARD	BUILDING HEIGHT MEASURING POINT
-E	EXISTING CABLE TELEVISION CONDUIT	8" S	PROPOSED SANITARY SEWER WITH STRUCTURE	EXISTING GAS VALVE	10"	EXISTING SIGN POST	PROPOSED BIKE RACKS
-	EXISTING ELECTRICAL CONDUIT	LOD	PROPOSED STORM DRAIN	EXISTING LIGHT POLE	12"	EXISTING WOOD POST	PROPOSED LIGHTS
-	EXISTING EDGE OF PAVEMENT		PROPOSED LIMITS OF DISTURBANCE	EXISTING PHONE PEDESTAL	15"	EXISTING INLETS	PEDESTRIAN LIGHTS
-	EXISTING FENCE LINE		PROPOSED STORM WATER EASEMENT	EXISTING PHONE MANHOLE	18"	EXISTING CURB INLET	PROPOSED PARKING LABELS
-	EXISTING NATURAL GAS CONDUIT		EXISTING PARKING LABEL	EXISTING SANITARY MANHOLE	24"	EXISTING CONCRETE	PROPOSED HARDSCAPE
-	EXISTING OVERHEAD WIRES		EXISTING SANITARY CLEANOUT	EXISTING TRAFFIC SIGNAL POLE	30"	EXISTING CURB AND GUTTER	PROPOSED FIRE HYDRANT
-	EXISTING TELEPHONE CONDUIT		EXISTING STORM DRAIN MANHOLE	EXISTING TRAFFIC SIGNAL POLE	36"	EXISTING BUILDING	DOOR LOCATION
-	EXISTING PUBLIC UTILITIES EASEMENTS		EXISTING ELECTRICAL JUNCTION BOX	EXISTING TREE	42"	EXISTING ELECTRICAL TRANSFORMER	PROPOSED SWM FACILITY
-	EXISTING SANITARY SEWER CONDUIT		EXISTING ELECTRICAL MANHOLE	EXISTING CABLE TELEVISION PEDESTAL	48"	EXISTING ASPHALT	FACILITY WITH CHEEK WALL AND CURB CUT
-	EXISTING STORM DRAIN CONDUIT		EXISTING FIRE DEPARTMENT CONNECTION	EXISTING UNKNOWN UTILITY MANHOLE	54"	EXISTING EASEMENT	
-	EXISTING WATER CONDUIT		EXISTING FIRE HYDRANT	EXISTING WATER METER	60"	EXISTING REINFORCED CONCRETE PIPE	
-	EXISTING ZONE LIMITS		EXISTING GAS MANHOLE	EXISTING WATER MANHOLE	66"	EXISTING CORRUGATED METAL PIPE	
-	PROPOSED 10' CONTOUR			EXISTING WATER VALVE	72"	EXISTING BUILDING RESTRICTION LINE	
-	PROPOSED 2' CONTOUR				78"	EXISTING RIGHT-OF-WAY	

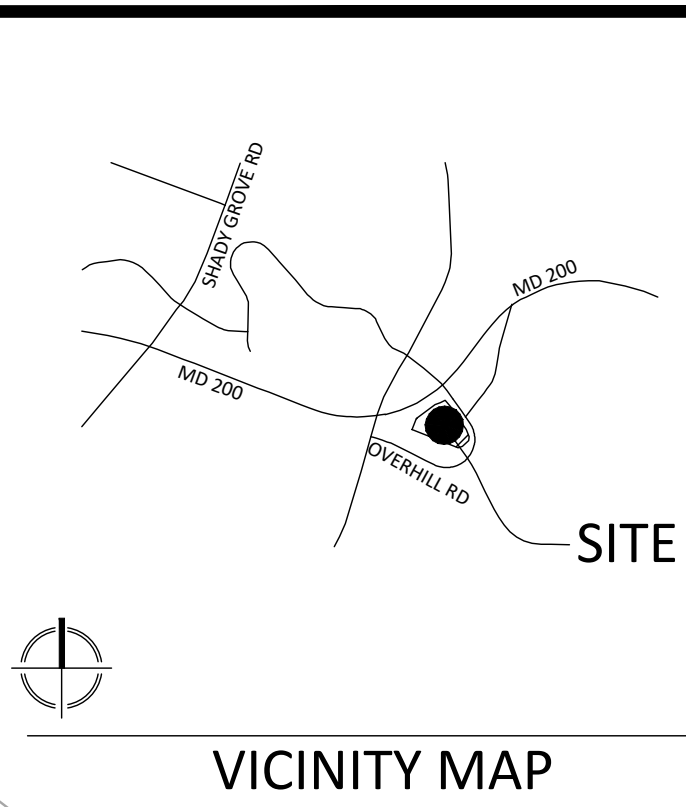

VIA
 VIKI MARYLAND, LLC
 20251 Century Blvd., Suite 400
 Germantown, MD 20874
 301.916.4100 | vika.com
 Our Site Set on the Future.

PREPARED FOR:
COMMUNITY HOUSING INITIATIVE, INC.
 1123 ORMOND COURT
 MCLEAN, VA 22101
 CONTACT: PATRICK BYRNE
 (703) 556-9569
 pbyrne@chdc.org

PLANNER/ENGINEER/LANDSCAPE ARCHITECT:
VIA MARYLAND, LLC.
 20251 CENTURY BLVD., SUITE 400
 GERMANTOWN, MD 20874
 CONTACT: JOSH SLOAN
 (301) 916-4100
 sloan@vika.com

ARCHITECT:
STUDIO K
 7806 JAKI TERRACE
 GLEN BURNE, MD 21060
 CONTACT: CHIP KEENER
 (301) 938-5195
 ckeener@studiokarch.net

TRAFFIC ENGINEER:
LENHART TRAFFIC CONSULTING, INC.
 645 BALTIMORE ANNAPOLIS BLVD.
 SUITE 214
 SEVERNA PARK, MD 21146
 CONTACT: NICK DRIBAN
 (410) 216-3333
 mlenhart@lenharttraffic.com

ATTORNEY:
MILES & STOCKBRIDGE
 11 NORTH WASHINGTON STREET
 SUITE 700
 ROCKVILLE, MD 20850
 CONTACT: SCOTT WALLACE
 (301) 762-1600
 swallace@MilesStockbridge.com



REVISIONS	DATE

**16998
 OVERHILL
 ROAD**

4TH ELECTION DISTRICT
 MONTGOMERY COUNTY,
 MARYLAND
 WSSC GRID: 223NW07
 TAX MAP: GT41

PRELIMINARY PLAN

120240060

PROFESSIONAL SEAL

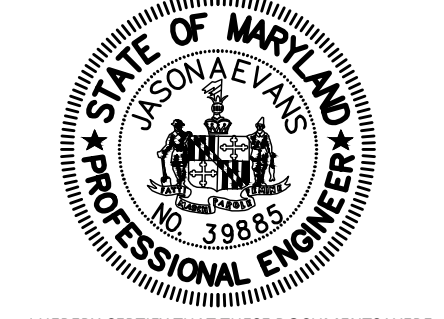

I HEREBY CERTIFY THAT THESE DOCUMENTS WERE PREPARED OR APPROVED BY ME, AND THAT I AM A LICENSED PROFESSIONAL ENGINEER UNDER THE LAWS OF THE STATE OF MARYLAND.
 LAST NAME: EVANS, JASON A.
 LICENSE NUMBER: 3885
 EXPIRATION DATE: JULY 16, 2025

THE INFORMATION, DESIGN AND CONTENT OF THESE DRAWINGS OR DOCUMENTS ARE PROPRIETARY TO VIA MARYLAND, LLC AND CONSTITUTE ITS PROPRIETARY INTELLECTUAL PROPERTY. THESE DRAWINGS AND/OR COPIES, DIGITALLY CONVERTED, MODIFIED OR USED FOR ANY PURPOSE, IN ANY FORMAT, WITHOUT PRIOR WRITTEN AUTHORIZATION FROM VIA MARYLAND, LLC, VIOLATION MAY RESULT IN PROSECUTION. ONLY APPROVED, SIGNED AND SEALED PLANS OR DRAWINGS MAY BE UTILIZED FOR CONSTRUCTION PURPOSES.

© 2025 VIA MARYLAND, LLC
 DRAWN BY: KP
 DESIGNED BY: JS/KP
 DATE ISSUED: 11/15/2023

VIA PROJECT 50571
 DRAWING NO.
 SHEET NO. PP-003

"FOR LOCATION OF UTILITIES CALL 8-1-1 or 1-800-257-7777 OR LOG ON TO www.call811.com or http://www.missutility.net 48 HOURS IN ADVANCE OF ANY WORK IN THIS VICINITY"

The acceptor must notify all public utility companies with underground facilities in the area of proposed excavation and have those facilities located by the utility companies prior to commencing excavation. The acceptor is responsible for compliance with requirements of Chapter 33A of the Montgomery County Code.

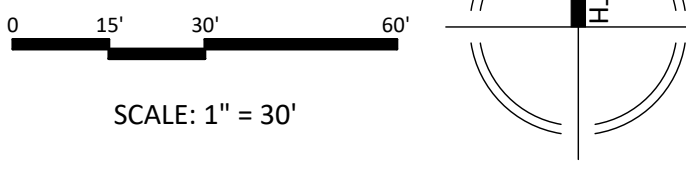

3.	Operations.....	12
D.	Environmental Issues	13
E.	Community Response	14
III.	FINDINGS OF FACT AND CONCLUSIONS OF LAW.....	14
A.	Necessary Findings (General Standards, Section 59.7.3.1.E)	15
1.	Substantial Conformance with the Master Plan	16
i.	Applicant’s Arguments	16
ii.	Opposition’s Arguments	17
2.	Adequate Public Services and Facilities	20
3.	No Undue Harm from Non-Inherent Adverse Effects	22
4.	Compatibility with the Neighborhood	24
B.	Development Standards of the Zone (Article 59.4)	26
C.	Use Standards for an Independent Living Facility for Seniors	27
D.	General Development Standards (Article 59.6)	33
1.	Parking and Loading	33
2.	Site Landscaping and Screening	34
3.	Outdoor Lighting	34
IV.	CONCLUSION AND DECISION	35

I. STATEMENT OF THE CASE

Filed on April 7, 2023, Community Housing Initiative, Inc. (hereinafter “Applicant”) applied for a conditional use for an Independent Living Facility for Seniors under Section 59.3.3.2.C of the Zoning Ordinance. The subject property is identified as 16998 Overhill Road, Tax Account number 00117554 which is located in Derwood, Maryland, 20855. Exhibit 1. The property is zoned RE-1. *Id.* On June 30, 2023, OZAH issued a Notice of Hearing scheduling the public hearing for Friday, August 4, 2023. Exhibit 28.

Staff of the Montgomery County Planning Department (Planning Staff or Staff) issued a report recommending approval of the conditional use application dated June 9, 2023, subject to the following conditions of approval (Exhibit 29, pp. 3):

1. The conditional use is limited to an Independent Living Facility for Seniors with 130 dwelling units.
2. The Applicant must abandon the exiting Special Exceptions associated with the Property.
3. The Project will contain 100% MPDU’s.
4. A Preliminary Plan of subdivision is required.
5. The Applicant must complete a noise analysis and demonstrate no future negative noise impacts at the time of Preliminary Plan if the use is approved.

At its meeting on July 6, 2023, the Planning Board recommended approval of the application with the conditions recommended by Staff. Exhibit 30. The Board also granted approval of a Preliminary Forest Conservation Plan (PFCP) for the project. Exhibit 38.

The public hearing proceeded in person as scheduled on August 4, 2023. The Applicant presented six witnesses: Patrick Byrne, Josh Sloan, Jason Evans, Charles (Chip) Keener, Dylan McAndrew, and Chris Barnobi. T. 3. Mr. Slone, Mr. Evans, Mr. Keener, Mr. McAndrew and Mr. Barnobi were qualified as experts in their respective fields. T. 28, 57, and 79. The record was left

open for 10 additional days until August 14, 2023 to allow for a transcript of the proceedings to be generated. T. 161.

II. FACTUAL BACKGROUND

A. Subject Property

The subject property is zoned RE-1 and consists of 3.77 acres identified as part of Lot 6 on Plat 1581, on Tax Map 04-00117554 also known as 16998 Overhill Road in Derwood, Maryland. Exhibit 29, pg. 5. A landscape contractor and associated storage yard under an approved Special Exception (CBA-2778) for Horticultural Nursey/Landscape Contractor currently operates out of the property with two points of access from Overhill Road. *Id.* The property contains Multiple outbuildings, landscape materials, stockpiles, and single-family dwelling. In the southwest corner of the property there is an area of stream valley buffer (SVB) associated with an offsite stream. *Id.*



Exhibit 29 – Figure 2 Subject Property, pg. 5

B. Surrounding Area

The “surrounding area” of a proposed conditional use is the area that will experience the direct impacts of the use. It is delineated and characterized in a conditional use case to determine whether the proposed use will be compatible with the properties that will be impacted. Once delineated, the Hearing Examiner must assess the character of the area to determine whether the impacts of the proposed conditional use will adversely affect that character.

The vicinity surrounding the Property is composed of low-density residential development, religious assembly use and three conditional uses/special exceptions. *Id.* at pg. 4. To the east, south and west all properties are zoned RE-1 with low-density residential uses, a religious assembly and a private club. *Id.* The ICC(MD-200) abuts the northern property line and Rock Creek Regional Park is to the southeast across Overhill Road from the subject property. *Id.* Staff identified the following three existing approved conditional uses/special exceptions within the defined neighborhood: 17001 Overhill Road: CBA1458 for a Private Club, Service Organization; 17001 Overhill Road: S2145-for a Telecommunications Facility; and 17001 Overhill Road: S-888 for a Telecommunications Facility. Staff defined the neighborhood/vicinity as outlined in yellow below.



Vicinity/Staff Defined Area
Exhibit 29 – Pg. 4

C. Proposed Use

The Applicant proposes to construct a new independent living facility for seniors. *Id.*, pg. 6, T. 10. The new independent living facility will contain 130 dwelling units all of which will be moderately priced (MPDUs). T. 10. To move forward with the proposed use, the Applicant must abandon the existing special exception for a horticultural nursery/landscape contractor. *Id.*



Exhibit 29, pg. 6 – Existing Site
Conditions – Figure 3

The new building will contain a combination of both one and two unit dwellings, contain many amenities, and employ a property manager, assistant property manager and a site porter. T. 12-13. All units will be occupied by persons 62 years of age and older, but more than likely the typical tenant will be “north of 70 years old.” *Id.* All units will be income restricted permanently reserved as MPDUs. T. 12. Amenities include an exercise room, game rooms, library/computer room, conference room and a large party room, a walking trail, gardens, and a dog run. T. 14-15.

Mr. Byrne, President of Community Housing, testified that his company operates a 121 independent living building, Willow Manner at Fairland and that they have 3 other projects

including the subject application in the pipeline in Montgomery County. T. 16. Mr. Byrne further testified that Montgomery County is 30,000 to 40,000 units short of affordable senior housing. T.16-17.

1. Site Plan and Floor Plan

Mr. Slone testified that the northern entrance point will remain for traffic entering the site and the parking areas will be located to the north of the building between the ICC. T. 30. He further stated that the parking area will be 10 feet below the berm into the slope protecting the Overhill Road view to keep more residential feel. T. 31. In addition, the building's L shape design creates a buffered back yard for the amenity spaces. *Id.*

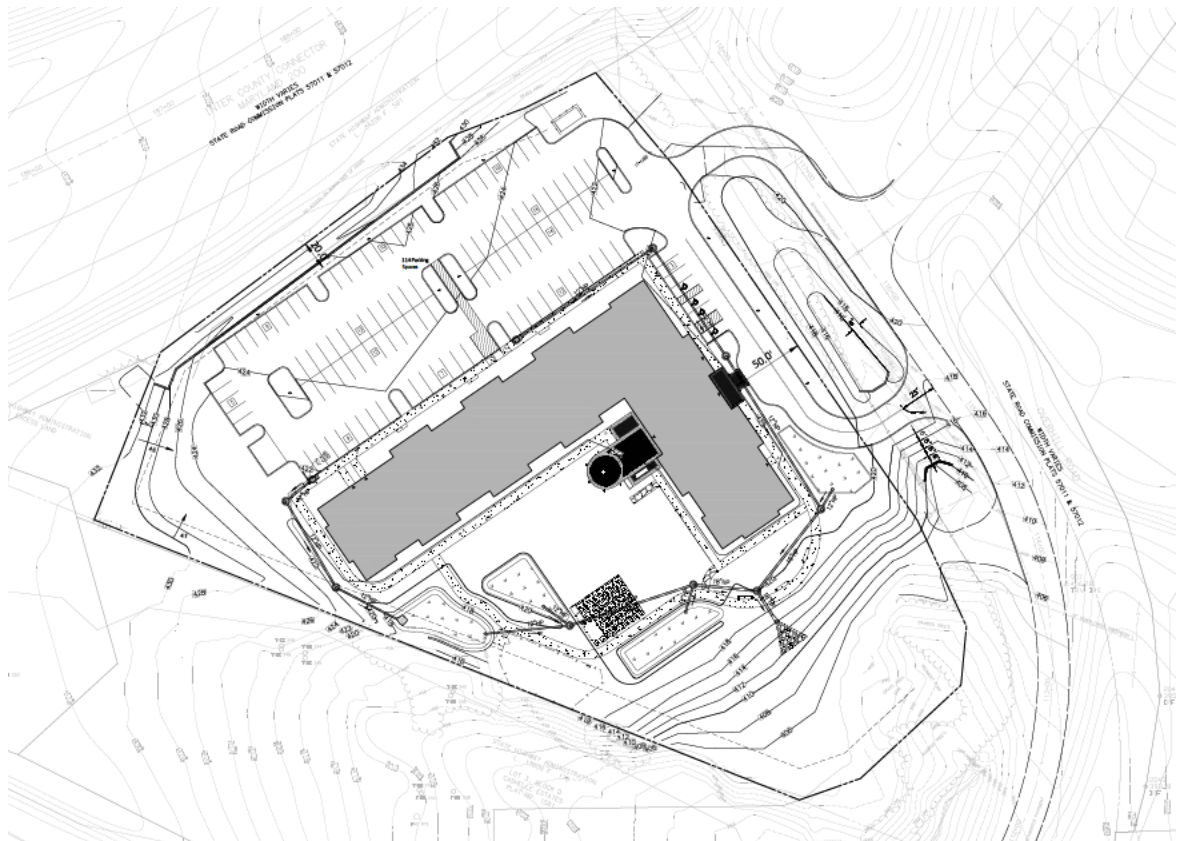

Exhibit 11(b) – CU Site Plan

Mr. Slone described the site plan pointing out the slopes, ingress, egress, trash pickup, deliveries, and amenities including outdoor kitchen seating areas, lawn, terrace, dog run and walking trails. T. 30-36. He testified that the project meets all development standards. T. 31.

Mr. Keener, the Applicant's expert architect, testified to the exterior design and interior floor plans. He noted that the site is removed from any established neighborhood having a specific architectural style. T. 73. Given the location and number of units, the design is more of an "urban style" with federal detailing using residential materials such lap siding, clay masonry, and stucco. *Id.* The main entrance of the building is on the east façade, street side and all the amenity and community spaces are located as you enter the building. T. 75. Each apartment meets the HUD and CBA requirements for size, circulation, etc. T. 76.



Exhibit 32, pg. 4 – Overhill Planning Set

2. Landscaping, Lighting, Parking and Signage

a. Landscaping

Mr. Slone testified that the project meets all the landscape and lighting standards. T. 30. Regarding specific plantings, Mr. Slone stated that street trees and shrubs will be planted along the front, the seating near the entry will be planted, and plantings will be placed between the sidewalk and the base of the building. T. 44. In addition, the parking lot will contain the required plantings and tree canopy, while the western boundary of the property will remain largely wooded. *Id.*

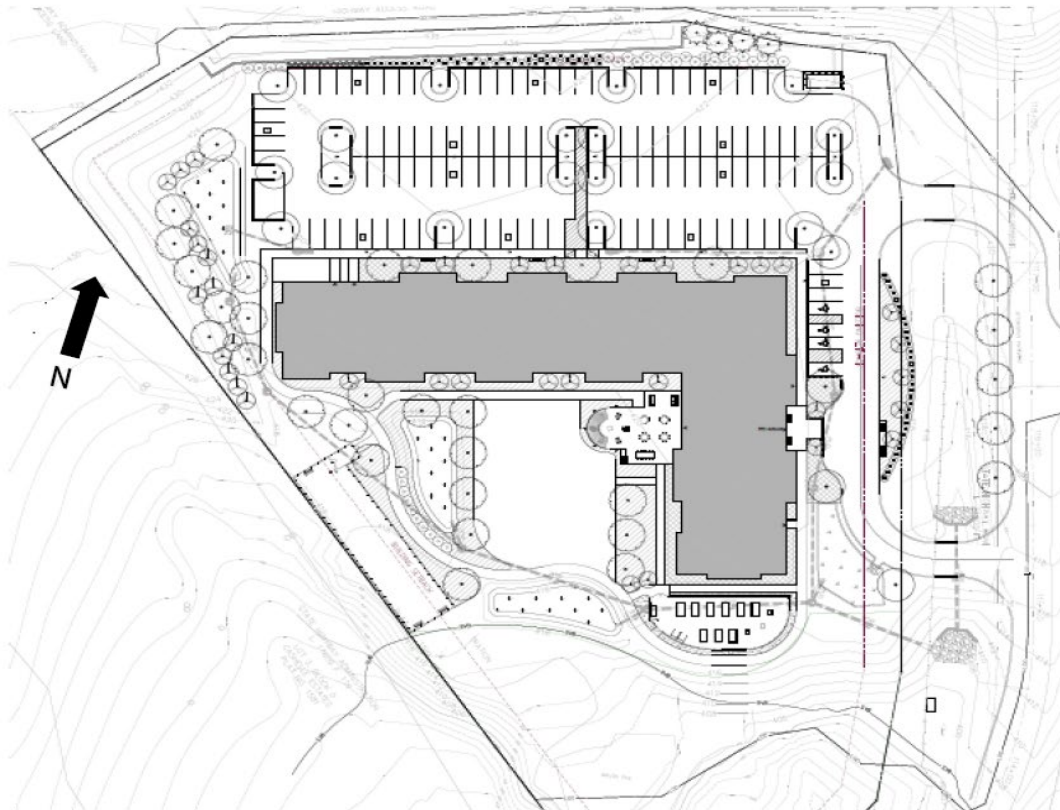

Exhibit 29, pg. 8 – Staff Report, Landscape Plan

b. Lighting

Mr. Slone testified that per the photometric plan zero footcandles are measured at the property boundaries except for along the eastern side of the property line where the streetlights cross the property line and have a little higher footcandle T. 42-43. The fixtures being used are “dark skies compliant” and they do not have any up light to add to light pollution up. *Id.* Mr. Slone reminded the Hearing Examiner that the property does not abut any residential properties and any lighting installed will not impact a residence. *Id.* Exhibits 33 (g) identifies exterior lighting locations and provide sufficient details of the lighting type and wattage to be used on site in addition to the testimony.

c. Parking

Residents and visitors will both park onsite and the number of spaces provided will exceed the code requirement. Exhibit 5, pg. 2. The senior living facility will supply 122 parking spaces.¹ Exhibit 16a-b. Mr. Byrne testified that a space will be provided for any resident who wishes to have a car, but in his experience not everyone who lives at the property will have a car. T. 148. Staff reviewed the proposed plan pursuant to the parking standards in a RE-1 zone and determined 98 spaces to be required. Exhibit 29, pg. 12.² The project will maintain the northern entrance point for traffic with the parking field to the north of the building. T. 31, 65. The existing northern entrance to the site meets county regulations for sight distance requirements as does the secondary entrance to the south. Exhibit 20, T. 65.

¹ Ms. Kosary testified parking on site would accommodate 109 cars. T. 128.

² See §59.6.3.I.2.b.

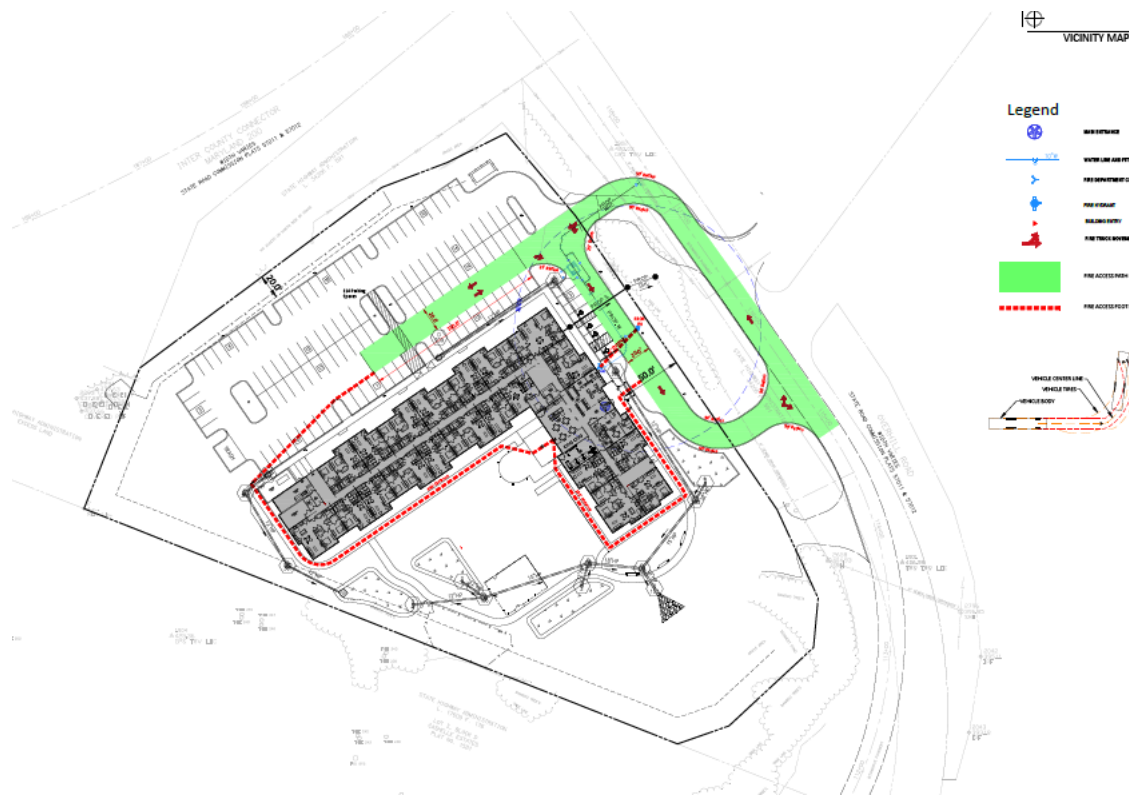

Ex. 12 – Fire Access Plan

d. Signage

No plan or architectural drawing identified signage. The Applicant provided no testimony regarding signage. As stated in the Staff Report, should the Applicant intend to install signage it must be reviewed and approved by the Department of Permitting Services and comply with the sign section of the Zoning Ordinance. Exhibit 28, pg. 13.

3. Operations

a. Staffing

The Applicant will employ 3 to 5 full time employees and 1 to 3 part time employees once the building is operational. Exhibit 5, pg. 1. Those employees will include a building manger,

maintenance professional and a leasing agent working 9am to 5 pm or 7 am to 7 pm if necessary.

Id. Any additional workers required for specific maintenance will be hired and managed by a the Property management company. *Id.* The Applicant third party manages projects with Habitat American and utilizes a team off-site supporting the on-site staff in areas of managing, marking and leasing. T. 13.

b. Trash Disposal

The trash and recycling areas will be to the afar northwest corner of the building and not visible from Overhill. T. 40. Trash pick-up will come in at the north entrance and be able to pick-up and circle out without any backups for noise reduction. *Id.*

D. Environmental Issues

By resolution dated July 20, 2023, the Planning Board granted a variance allowing the removal of eight protected trees and critical root zone impact on two protected trees and approved the Forest Conservation subject to the following conditions:

1. Before recordation of the plat and the start of any demolition, clearing, grading, or construction, whichever comes first, for this development Application, the Applicant must record a Category I Conservation Easement over all areas of forest retention, forest planting and environmental buffers as specified on the approved Final Forest Conservation Plan (“FFCP”). The Category I Conservation Easement must be in a form approved by the MNCPPC Office of the General Counsel and must be recorded in the Montgomery County Land Records by deed. The Book/Page for the easement must be referenced on the record plat.
2. The Applicant must plant the variance tree mitigation plantings on the Subject Property with a minimum size of 3 caliper inches totaling 77 caliper inches. Planting locations must be shown on the FFCP.
3. The Applicant must submit a FFCP for review and approval before obtaining a Sediment and Erosion Control Permit from the Montgomery County Department of Permitting Services for this Subject Property.
4. The FFCP must be consistent with the approved Preliminary Forest Conservation Plan. Exhibit 38.

An area of SVB associated with an offsite stream is located in the southwest corner of the property. Exhibit 29, pg. 5. Mr. Slone testified to the Applicant's efforts toward environmental remediation, cleanup and site improvements. T. 35. The Applicant plans to focus on runoff from the parking lot and roof structures, focus the forest conservation on the SVB, and in the bioretention areas plant a mix of habitat providing plantings to meet the pollinator and songbird requirements all placed along what is forested land transitioning between lawn, formal garden areas and the natural areas. T. 35-36.

E. Community Response

The Applicant hosted two community meetings, January 2022 and January 2023 and provided notices to all the surrounding neighbors as required. T. 17, 20-21. The meetings were conducted virtually and were attended by some immediate neighbors and some from outside the immediate community. *Id.* As of the date of the Staff Report, June 9, 2023, Staff did not receive any public correspondence regarding the application. Exhibit 29. Ms. Carol Kosary was the only community member to appear in opposition of the application. OZAH received into evidence two letters of support, one from YIMBY Action and the other from Shady Grove Presbyterian Church. Exhibits 36 and 37.

III. FINDINGS OF FACT AND CONCLUSIONS OF LAW

A conditional use is a zoning device that authorizes certain uses provided that pre-set legislative standards are met. Pre-set standards are both specific (to a particular use) and general (applicable to all conditional uses). The specific standards applied for an Independent Living Facility for Seniors are in Section 59.3.3.2.C.2.b of the Zoning Ordinance. The general standards (termed "Necessary Findings" in the Zoning Ordinance) for all conditional uses are found in Section 59.7.3.1.E. An applicant must prove that the use proposed meets all specific and general

standards by a preponderance of the evidence. The Hearing Examiner concludes that Applicant has done so in this case, with the conditions of approval included in Part IV of this Report.

A. Necessary Findings (General Standards, Section 59.7.3.1.E)

The relevant standards and the Hearing Examiner's findings for each standard are discussed below.³ For discussion purposes, the general standards may be grouped into four main areas:

1. Substantial Conformance with the Master Plan;
2. Adequate Public Services and Facilities;
3. No Undue Harm from Non-Inherent Adverse Effects; and
4. Compatibility with the Neighborhood

E. Necessary Findings

1. To approve a conditional use application, the Hearing Examiner must find that the proposed development:

- a. satisfies any applicable previous approval on the subject site or, if not, that the previous approval must be amended;***

Conclusion: The property currently operates a Horticultural Nursery/Landscape Contractor use pursuant to an approved special exception (CBA-2778). The granting of the proposed conditional use will supersede existing special exception and abandonment of the existing special exception will be a required condition for approval of the pending Application.

- b. satisfies the requirements of the zone, use standards under Article 59.3, and to the extent the Hearing Examiner finds necessary to ensure compatibility, meets applicable general requirements under Article 59.6;***

Conclusion: This subsection requires review of the development standards of the RE-1 Zone contained in Article 59.4; the use standards for an Independent Living Facility for Seniors contained in Article 59.3; and the applicable development standards contained in Article 59.6.

³ Although §59.7.3.1.E. contains six subsections (E.1. through E.6.), only subsections 59.7.3.1.E.1., E.2. and E.3. contain provisions that apply to this application. Section 59.7.3.1.E.1. contains seven subparts, a. through g.

Each of these Articles is discussed below in Parts III.B, C, and D, of this Report, respectively. For the reasons explained there, the Hearing Examiner finds that the application satisfies these requirements.

1. Substantial Conformance with the Master Plan

c. substantially conforms with the recommendations of the applicable master plan;

Staff identified that the Property is within the boundary of the Upper Rock Creek Master Plan (Plan) and, the proposed use is in conformance with the Plan. Exhibit 29, pg. 13. The project replaces a commercial use with a residential use, will provide significant forest restoration and a significant portion of the stream valley buffer with afforestation in line with the Plan goals. *Id.* at 14. The Plan last approved and adopted in 2004, does not specifically mention this property and at that time the right-of-way for the ICC was unknown. T. 46. A primary goal of the Plan is to “protect environmental resources and maintain stream quality”. *Plan*, pg. 7. The Plan also seeks to preserve the residential character by encouraging integration of new and existing communities with emphasis on design and preservation of open space.” *Id.* at 8. The Plan provides land use recommendations for the major undeveloped properties in the “residential wedge.” *Id.* at 14. The Plan recommendations focused on evaluating cluster development using community sewer and large lot development using septic systems allowing cluster development with community sewer service to increase the amount of land in an undeveloped natural state. *Id.*

i. Applicant’s Arguments

The Applicant states that because of the highway and significant right-of-way parcels surrounding the property, the facility will have no effect on the area’s residential character and removal of the existing commercial use will enhance the residential character of the neighborhood. Exhibit 23, pg. 9. The Applicant’s expert testified to the concept of “residential wedges” as set forth

in the Plan. T. 46-48. Mr. Slone testified that at the time of the Plan's adoption, it called for intense development to run along several corridors that "run out on spokes on 495 [a]nd then within those corridors are residential areas." T. 47. Mr. Slone noted that County recently adopted the Thrive Montgomery 2050 Plan (Thrive) which is now the County's general plan.⁴ *Id.* Regarding "wedges and corridors", Mr. Slone notes that Thrive determined setting aside these areas for single-family detached housing created significant inequities and detracted from the ability to provide housing for more people, a more diverse population and an aging population. *Id.* Mr. Slone argues that converting the existing commercial use into a residential one will bring it more into conformance with the Plan, and further the affordable housing for an aging population moves the use "towards the Thrive plan." *Id.* Mr. Slone, during Ms. Kosary's questioning, agreed that the property is in a "limited growth area" under Thrive. T. 56. Mr. Slone referred to Thrive, pg. 72 during rebuttal questioning quoting "limited growth area contains the mainly suburban residential communities where limited organic growth is envisioned to meet local needs for services, provide a diverse range of housing choices, and increase racial and socioeconomic integration to achieve complete communities." T. 58.

ii. Opposition's Arguments

Ms. Kosary during her testimony stated that the Plan has two co-equal goals 1) protection of environmental resources throughout the entirety of the Plan area and 2) preserve the residential character by keeping the residential wedge area within the Plan at a low density. T. 102. She argues that Thrive remains consistent with the Plan's environmental goals by managing development and keeping densities low to protect the Upper Rock Creek watershed and points to

⁴ Montgomery County Council adopted Resolution 19-1413, Thrive Montgomery 2050, as amended by the Council on October 25, 2022.

page 35 of the Plan that states “[t]his plan does not substantially increase zoning densities in the area which means that Upper Rock Creek will remain generally less conducive to affordable and elderly housing than other areas with more extensive infrastructure and zones that permit higher density.” T. 103-104. Ms. Kosary disagreed with Applicant’s expert that if the Plan were rewritten today due to the location and degraded nature of the site it would be on the list of locations for affordable elderly housing. T. 106. She believes the fact that the property is within a residential wedge, zoned RE-1, and drains to a sensitive use class 4 watershed produces the opposite conclusion. *Id.* Ms. Kosary also directed the Hearing Examiner to the analysis of the Plan conducted in CU18-08, Primrose School where that Hearing Examiner determined the proposed 195-child day care center on lot developed only 1,200 square foot residential home and no significant environmental features to not be compatible with the Plan. Exhibit 44. Both parties agree that the current site is in a poor degraded condition. Exhibit 23, pg. 9; T. 107.

Conclusion: Based on this record, the Hearing Examiner finds that the independent living facility for seniors will substantially conform to the recommendations of the Plan. The Hearing Examiner agrees with the Applicant’s expert’s that to determine the proposed use’s conformance with the Plan, one must take into consideration the age of the Plan, the location of the ICC chosen after Plan adoption, the property’s location in conjunction with abutting properties, the ICC’s impact on the property and the impact of the adoption of Thrive.

As stated above, the Plan seeks to preserve the residential character of the planning area. The Hearing Examiner finds that termination of the existing commercial special exception and restoration of a residence use to the property to be in keeping with the Plan’s goals and the goals of Thrive to address inequities and provide housing for more people. Upon review of the analysis of the Plan previously completed for the Primrose School, she finds the proposed use

and its impact on the property differs significantly from that of the Primrose School. The Primrose School sought to develop an existing single-family low-density lot abutting other single-family low-density lots. The subject property abuts no other residential properties and currently operates a large-scale commercial use. The Plan's emphasis of creating residential wedge development specifically refers to undeveloped land intending to preserve undeveloped land, open space and to create/preserve low density residences. Plan pg. 14. Converting the existing with commercial use with the proposed senior living facility creates a residential use in keeping with the Plan and preserves other undeveloped tracts and existing low density residential lots.

The Hearing Examiner finds that the proposed use is in keeping with the Plan's goal to protect of environmental resources. The lot in the Primrose School contained no environmentally sensitive features, while the existing property contains an environmentally destructive commercial operation, an existing stream, small tributary and associated wetlands all in a degraded state. The building's footprint, i.e., lot coverage, will be similar to low-density residences in the area, the termination of the existing commercial special exception and proposed development will significantly improve the stream valley buffer and stormwater management on this property. The Hearing Examiner agrees Staff that the proposed senior living facility will provide significant forest restoration and be compatible with the uses in the Surrounding Neighborhood in conformance with the Plan. Exhibit 29, pg. 14.

e. will not, when evaluated in conjunction with existing and approved conditional uses in any neighboring Residential Detached zone, increase the number, intensity, or scope of conditional uses sufficiently to affect the area adversely or alter the predominantly residential nature of the area; a conditional use application that substantially conforms with the recommendations of a master plan does not alter the nature of an area;

Staff identified three approved Special Exception within the Neighborhood; two for Telecommunications Facilities (cell towers) and the existing Special Exception for the landscape contractor and storage yard on the property. Exhibit 29 pg. 14. Staff concluded if approved the facility will not increase the number of conditional uses/special exceptions and will not alter the character of the neighborhood and conform with the Plan. *Id.*

Conclusion: The Hearing Examiner agrees the proposed conditional use will not increase the number, intensity or scope of conditional uses sufficiently to affect the area adversely. She has already found that the project conforms to the Plan. The location of the parking lot closest to the ICC, maintenance of the northern entrance and location of the building itself will protect the view from Overhill Road. In addition, the termination of the existing use, the building location, design, setbacks and landscaping will add to the residential character. For reasons stated in Part III.A.4 of this Report below, she agrees with Staff that the project will be compatible with the surrounding area.

2. Adequate Public Services and Facilities

f. will be served by adequate public services and facilities including schools, police and fire protection, water, sanitary sewer, public roads, storm drainage, and other public facilities. If an approved adequate public facilities test is currently valid and the impact of the conditional use is equal to or less than what was approved, a new adequate public facilities test is not required. If an adequate public facilities test is required and:

i. if a preliminary subdivision plan is not filed concurrently or required subsequently, the Hearing Examiner must find that the proposed development will be served by adequate public services and facilities, including schools, police and fire protection, water, sanitary sewer, public roads, and storm drainage; or

ii. if a preliminary subdivision plan is filed concurrently or required subsequently, the Planning Board must find that the

proposed development will be served by adequate public services and facilities, including schools, police and fire protection, water, sanitary sewer, public roads, and storm drainage; and

Conclusion: The Hearing Examiner is not required to make a finding regarding the adequacy of public services and facilities in this case because submittal of a preliminary plan to the Planning Board will be required for approval. Exhibit 29, pg. 15. Mr. Evans, Applicant's engineering expert testified that in his opinion the conditional use will be served by adequate public facilities. T. 67. Staff commented that as a residence for seniors, school adequacy does not present an issue and the property is served by existing water and sewer and that the other utilities public facilities, police, fire and health services are all operating within the standards set by the Growth and Infrastructure Policy. *Id.*

However, adequacy of public transportation and pedestrian access was raised by the opposition. Staff noted that pedestrian facilities are entirely internal to the subject property. Exhibit 29, pg. 15. Staff indicated they will continue to work with the Applicant and SHA to establish an easement to provide adequate pedestrian access to both Redland Road and the nearby Ride-On bus stops prior to preliminary plan review. *Id.* Staff identified Redland Road as a primary residential road and Overhill Road as a tertiary residential street. Exhibit 35. Mr. Slone, Applicant's expert testified that while there is a bus stop available there is no sidewalk to get to the bus stop and that under the LATR one is not required, and he anticipates most residents will drive a short distance rather than take public transportation. T. 54. Access to public transportation as it relates to development standards will be further discussed below in Section C. below.

From this evidence, the Hearing Examiner finds as part of the preliminary plan approval adequate public transportation may require further review, but all other public facilities appear to be met.

3. No Undue Harm from Non-Inherent Adverse Effects

g. will not cause undue harm to the neighborhood as a result of a non-inherent adverse effect alone or the combination of an inherent and a non-inherent adverse effect in any of the following categories:

- i. the use, peaceful enjoyment, economic value or development potential of abutting and confronting properties or the general neighborhood;*
- ii. traffic, noise, odors, dust, illumination, or a lack of parking; or*
- iii. the health, safety, or welfare of neighboring residents, visitors, or employees.*

Conclusion: This standard requires consideration of the inherent and non-inherent adverse effects of the proposed use on the surrounding area. Inherent adverse effects are “adverse effects created by physical or operational characteristics of a conditional use necessarily associated with a particular use, regardless of its physical size or scale of operations.” *Zoning Ordinance*, §1.4.2. Inherent adverse effects, alone, do not justify the denial of a conditional use. Non-inherent adverse effects are “adverse effects created by physical or operational characteristics of a conditional use not necessarily associated with the particular use or created by an unusual characteristic of the site.” *Id.* Non-inherent adverse effects may be a basis to deny a conditional use, alone or in combination with inherent effects, if they cause “undue” harm to properties in the surrounding area.

Staff focused on the following seven characteristics in determining the impact of adverse effects on the neighborhood: size, scale, scope, light, noise, traffic and environment. Exhibit 29, pg. 17. Staff concluded that the following physical and operational characteristics are inherent to the proposed independent living facility for seniors:

- Temporary construction noise;
- Vehicle trips;
- Onsite lighting; and

- Waste management trucks. *Id.*

Further Staff did not identify any non-inherent adverse effects that would be detrimental to the neighborhood. *Id.* The Hearing Examiner agrees with Staff's list of inherent adverse characteristics of this use and that there are no additional non-inherent adverse impacts.

The Applicant's expert, Mr. Slone testified to the project's inherent/non-inherent impacts. Specifically, he identified those to be the building, parking lot, lighting, trash, and traffic, and he reached the same conclusions as Staff that those inherent elements did not create any adverse impacts to the neighborhood. T. 51-52. Further he opined the building was designed with trash and generators to the far end of the property to protect neighborhood consisting of the church, Knights of Columbus, cell tower and the houses further away would not suffer from any adverse impacts and determined that no non-inherent impacts exist. *Id.* and T. 94. T Staff found the proposed building and site design to be compatible with the surrounding neighborhood, the new landscaping and screening will limit the visual impact of the parking lot, will not cause any objectional noise, fumes or illumination or decrease in the economic value of the surrounding properties. Exhibit 29, p. 17. Applicant's traffic expert, Mr. McAndrew, testified that less than 50 peak hour per trips will occur from the site so that no traffic report was required for the project due to the low maximum number of trips generated by the use. T.81. Mr. McAndrew further explained that he ran a trip generation for the existing use based on square footage and then deducted that number from the new trips added by the senior housing facility. *Id.*

Ms. Kosary argues car trips and traffic given the location will create an adverse impact and that the Applicant should have gone above the LATR code requirement to determine actual the actual trips during a day for a better understanding of the traffic impact generated at the site. T. 85. She points out that Overhill Road is a substandard dead-end road without shoulders. T. 127.

Ms. Kosary referred to the Hearing Examiner's decision in CU19-04 in which the conditional use was denied because of the traffic burden on the neighborhood and the adverse effects to the "use and peaceable enjoyment of abutting property owners". T. 125.

In reviewing CU19-04 with the facts presented in the current matter, the uses and vehicles traveling to and from the properties are completely different. In addition, the abutting property owners to the property in the instant case include a church and SHA and the cars traveling from the site will more than likely not pass any existing residential properties on Overhill Road. The Hearing Examiner agrees with Staff and the expert testimony presented by the witnesses that the project does not result in undue adverse effects requiring denial of this application.

As stated above non-inherent adverse effects may result from the "physical or operational characteristics of a conditional use not necessarily associated with the particular use or created by an unusual characteristic of the site". Staff did not identify any non-inherent adverse impacts from the proposed use or site. The Hearing Officer agrees with Staff that there are no non-inherent adverse effects from the proposed development and concludes that use and proposed development will not cause undue harm to the neighborhood from either non-inherent adverse effects or a combination of inherent or non-inherent adverse effects.

4. Compatibility with the Neighborhood

Several sections of the Zoning Ordinance require a proposed conditional use be compatible with the character of the surrounding neighborhood.

Section 59.7.3.1.E.1 includes the standards of approval below:

d. is harmonious with and will not alter the character of the surrounding neighborhood in a manner inconsistent with the [master] plan.

Section 59.7.3.2.E.2 contains an additional requirement for conditional uses in single-family detached zones:

2. Any structure to be constructed, reconstructed, or altered under a conditional use in a Residential Detached zone must be compatible with the character of the residential neighborhood.

Staff concluded that the project met the standard of 59.7.3.1.E.1.d because (Exhibit 29, p. 14):

The parking facility will be located on the northwest side of the property between the proposed building and the ICC, MD-200. The Applicant is proposing landscaping around the building and the parking facility to make it compatible with the surrounding neighborhood. The proposed building will be sitting back from Overhill Road 50 feet or more. The residential use of an Independent Living Facility for Seniors is more harmonious with the surrounding neighborhood than the existing commercial landscape contractor use currently onsite.

Staff found that the project was compatible with the neighborhood (Section 59.7.3.1.E.1.2) because (*Id.* at 18) because:

The proposed building will be constructed to a similar height to the maximum allowed in the RE-1 zone and will be setback 50 feet from the front lot line. The parking facility will be located on the northwest side of the property between the proposed building and the ICC, MD-200. The Applicant is proposing landscaping around the building and the parking facility to provide sufficient screening with the surrounding neighborhood.

The Applicant's expert architect, Mr. Keener testified that from an architectural perspective the project will be compatible with the surrounding neighborhood. T. 76. He testified that the design concept was to maintain a residential appearance using materials that are familiar with residential style of architecture with some federal detailing and maintained a flat roof so it would not seem too "monolithic." T. 74. The materials used on the exterior include lap siding, clay masonry, veneer, and fiber cement panels similar to a stucco finish. T. 73. Additionally, Mr. Slone noted that the building design is a L shape to create a buffered back yard with the long part of the L from the front area heading to the West with the parking behind and to the side of the building.

T. 31-32. The location of the parking and building was done specifically to protect the view of people on Overhill Road and keep it more residential in character with along with the landscape design on Overhill Road. T. 31. In addition a significant forested right-of-way, deep front setback and new conservation plants will screen the building from Overhill Road. Exhibit 4, pg. 13.

For these reasons, the Hearing Examiner finds that the use is compatible with the surrounding neighborhood in a manner consistent with the Plan and will not adversely affect the character of the surrounding area.

Section 59.7.3.1.E.3. The fact that a proposed use satisfies all specific requirements to approve a conditional use does not create a presumption that the use is compatible with nearby properties and, in itself, is not sufficient to require conditional use approval.

Conclusion: The application satisfies all specific requirements for the conditional use, and with the conditions imposed, meets the standards required for approval.

B. Development Standards of the Zone (Article 59.4)

To approve a conditional use, the Hearing Examiner must find that the application meets the development standards of the RE-1 Zone, contained in Article 59.4 of the Zoning Ordinance. Staff included a table (Exhibit 29, p.11, shown on the next page) in its report comparing the minimum development standards of the RE-1 Zone to what is proposed in this application. Mr. Slone testified that the project meets all the development standards and no waivers from any standard is being request. T. 30.

Conclusion: Nothing contradicts Staff's assessment of compliance with the development standards of the Zone. The Hearing Examiner finds that the proposed facility complies with the standards of the RE-1 Zone.

Table 1: Development and Parking Standards (RE-1)

Development Standard Section 59.4.4.6.B.1	Permitted/ Required	Existing/Proposed
Minimum Lot Area	40,000 sq. ft.	164,713 sq. ft. (3.78 ac)
Minimum Lot Width at Front Building Line	125 ft.	187 ft.
Minimum Lot Width at Front Lot Line	25 ft.	177 ft.
Maximum Density		
Total Units	n/a units	130 units
Affordable Units	30% MPDU's	100% MPDU's
Maximum Lot Coverage	15% (24,707 sq. ft.)	15% (24,707 sq. ft.)
Minimum Front Setback	50 ft.	50 ft.
Minimum Side Street Setback	20 ft.	20 ft.
Minimum Side Setback	25 ft.	n/a
Minimum Sum of Side Setbacks	35 ft.	n/a
Minimum Rear Setback	25 ft.	n/a
Maximum Height **	60 ft.	60 ft.
Green Area Minimum	50% (82,356 sq. ft.)	50% (82,356 sq. ft.)
Vehicle Parking Requirement (Section 59.6.2.4.B) Spaces/Unit	0.75 spaces/unit*= 98	122 spaces

* Per Section 59.6.3.1.2.b: Adjustment factor for Age-Restricted Housing

** Per Section 59.3.3.2.C.2.c.iv

Staff Report - Exhibit 29, pg. 11, Table 1

C. Use Standards for an Independent Living Facility for Seniors (Section 59.3.3.2.C.2.b.)

The specific use standards for approval of an Independent Living Facility for Seniors or Persons with Disabilities are set out in Section 59.3.3.2.C.2.b. of the Zoning Ordinance.

Zoning Ordinance §59.3.3.2.C.

C. Independent Living Facility for Seniors or Persons with Disabilities

1. Defined

Independent Living Facility for Seniors or Persons with Disabilities means a building containing dwelling units and related services for senior adults or persons with disabilities. Independent Living Facility for Seniors or Persons with Disabilities includes meal preparation and service, day care, personal care, nursing or therapy, or any service to the senior adult or disabled population of the community that is an ancillary part of one of these operations.

The Zoning Ordinance defines a “senior adult” as “A person who is 62 years of age or older.”
Zoning Ordinance, §59.1.4.2.

Conclusion: The Applicant’s Amended Statement of Justification states that it meets this definition as does the Staff Report. Exhibits 4, 29. Mr. Byrne testified that the facility will be used to provide housing for seniors aged 62 and older. T. 12. A condition of approval will require that occupants meet the age ranges specified by the Zoning Ordinance for this use. As conditioned, the use meets this definition.

2. Use Standards

a. Where an Independent Living Facility for Seniors or Persons with Disabilities is allowed as a limited use, it must satisfy the following standards:

i. The facility must meet all applicable Federal, State, and County licensure, certificate, and regulatory requirements.

Conclusion: A condition of approval will require the above. Therefore, the use as conditioned will meet this requirement.

ii. Resident staff necessary for the operation of the facility are allowed to live on-site.

Conclusion: While the Zoning Ordinance does not prohibit Staff from living on-site, the Applicant stated management staff will be on-site only during business hours, i.e. no staff will live on-site. T. 13 and Exhibit 5.

iii. Occupancy of a dwelling unit is restricted to the following:

(a) a senior adult or person with disabilities, as defined in Section 1.4.2, Defined Terms;

(b) the spouse of a senior or disabled resident, regardless of age or disability;

*(c) a resident care-giver, if needed to assist a senior or disabled resident;
 or*

(d) in a development designed primarily for persons with disabilities rather than senior adults, one parent, daughter, son, sister, or brother of a handicapped resident, regardless of age or disability.

(e) Age restrictions must satisfy at least one type of exemption for housing for older persons from the familial status requirements of the federal "Fair Housing Act," Title VIII of the Civil Rights Act of 1968, as amended.

Conclusion: A condition of approval will require compliance with the age restrictions stated above. The use as proposed and conditioned meets these requirements.

b. Where an Independent Living Facility for Seniors or Persons with Disabilities is allowed as a conditional use, it may be permitted by the Hearing Examiner under all limited use standards, Section 7.3.1, Conditional Use, and the following standards:

i. The site or the proposed facility has adequate accessibility to or provides on-site public transportation, medical service, shopping areas, recreation and other community services frequently desired by senior adults or persons with disabilities. The application must include a vicinity map showing major thoroughfares, public transportation routes and stops, and the location of commercial, medical and public services within a one-mile radius of the proposed facility.

Staff identified the subject property as being within 5 miles or less of multiple shopping centers containing grocery stores, pharmacies, restaurants, financial institutions, etc. and that the Shady Grove Metro Station to be 1.25 miles from the subject property. Exhibit 29, pg. 9 and Exhibit 23, pg. 4. Mr. Slone testified to the greater vicinity map in the Land Use Report, that many of the residents will have cars and he expects many will drive a short distance to commercial centers. T. 53-54. Further he opined that many of the residents will take advantage of the numerous amenities on site and that in his opinion the site has adequate accessibility to the types of services a senior community would need. T. 54. Mr. Byrne testified that in his experience most residents of senior independent living facilities would have cars and that the people who do not have cars rely on other residents or family and friends to drive them short distances. In addition, residents use Uber and Lyft and that a benefit of a senior living in Montgomery County, residents 62 and older can access free ride services. T. 146-146. Mr. Byrne also stated that in his experience most seniors do not take public transportation and his staff would not encourage residents to use

public transportation. T. 146. In addition, Mr. Byrne stated that once the building is stabilized, his organization would make a determination if a small van service is needed to make weekly trips to shopping for residents. *Id.* The Applicant also provided a letter from the third-party property management company, Habitat America, indicating that senior residents rarely use public bus transportation because of the availability of ride-sharing apps, help from family and friends and the numerous services that existing to provide transportation to low-income seniors. Exhibit 49.

Ms. Kosary stated that no public transportation exists on Overhill Road and no path or easement exists to allow easy access from the site to the existing bus stops on Redland Road. T. 113-114. Ms. Kosary, discussed the “pedestrian comfort level” and identified the walk to the bus station as “uncomfortable or undesirable in much of the area surrounding the site.” T. 114. Ms. Kosary disagreed with the Applicant’s characterization of the nearby large commercial areas as being nothing more than small strip malls. T. 120. In addition, she noted the difficulty in walking to any recreation or park facilities. T. 122.

Conclusion: The Applicant provided the map required by this section. Exhibit 23, pg. 4. From the evidence in this record, the Hearing Examiner finds that this criterion for approval has been met, with the condition proposed. While public transportation is available on Redland Road, it may be difficult for residents to access, and the existing bus schedules may not be convenient to residents. Shady Grove Metro Station being over a mile away is not necessarily walkable for the residents from the subject property. However, the Hearing Examiner finds the alternate transportation to be readily accessible to the residents enabling adequate access. The Applicant’s expert opined that most seniors drive to the areas they need to access. Mr. Slone also reiterated the number of amenities available onsite that would limit the needs for residents to drive everywhere for everything. In addition, Mr. Wallace who has been in the senior housing business

for many years affirmed Mr. Slone’s opinion. In addition, the letter from Habitat America also asserts that residents rarely use public transportation and highlighted the number of readily available ride services for residents. Many recreation amenities are available onsite and with the “ride” options available to residents’ access to more than just the commercial center located within a mile of the property will be easily accessed.

ii. The Hearing Examiner may restrict the availability of ancillary services to nonresidents and specify the manner in which this is publicized. Retail facilities may be included for the exclusive use of the residents of the building.

Conclusion: The Applicant does not propose ancillary or retail services to non-residents. Exhibit

5. This will be made a condition of approval of the use.

iii. A minimum of 15% of the dwelling units is permanently reserved for households of very low income, or 20% for households of low income, or 30% for households of MPDU income. If units are reserved for households of more than one of the specified income levels, the minimum percentage must be determined by agreement with the Department of Housing and Community Affairs under Executive regulations. Income levels are defined in Section 1.4.2, Defined Terms.

The income levels are defined as follows (*Zoning Ordinance*, §5.1.4.1):

1. Very Low Income: Income at or below 50% of the area median income (as determined annually by the U.S. Department of Housing and Urban Development) adjusted for household size.
2. Low Income: At or below 60% of the area median income (as determined annually by the U.S. Department of Housing and Urban Development), adjusted for household size.
3. Moderately Priced Dwelling Unit (MPDU): Any dwelling unit that meets the requirements for a moderately priced dwelling unit in Chapter 25A.

Conclusion: Mr. Byrne testified that 100% of the units the occupancy of the units will meet these income requirements. T. 12. Staff also. A condition of approval will require compliance with this provision of the Zoning Ordinance. Given Mr. Byrne’s uncontroverted testimony and with the condition of approval, the use as proposed and conditioned will meet this criterion of approval.

iv. The maximum building height of an Independent Living Facility for Seniors or Persons with Disabilities is 60 feet and the maximum density is determined by the Hearing Examiner under the development standards of Section 3.3.2.C.2.b.vi through Section 3.3.2.C.2.b.ix, without regard to any other limitation in this Chapter.

Conclusion: As already explained, the building height proposed is 60 feet. This standard is met.

v. Height, density, coverage, and parking must be compatible with surrounding uses and the Hearing Examiner may modify height, density, coverage, and parking to maximize the compatibility of buildings with the residential character of the surrounding neighborhood.

Staff concluded that the application met this standard because (Exhibit 29, p. 10):

The height of the proposed building is not much taller than that allowed in the RE-1 zone which has a maximum height of 50'. The parking facility is along the northern property boundary abutting the ICC, MD-200 surrounded by landscaping to be more compatible with the residential character of the neighborhood.

Conclusion: The Hearing Examiner has already found that the building is compatible with the surrounding area. For the same reasons stated earlier in Section III of this Report, she finds that this standard has been met.

vi. The minimum front setback to the street for a lot abutting a property not included in the application is equal to the front setback for a detached house in the underlying zone under the standard method of development. Except for an access driveway, this front setback area must be maintained as a green area.

Conclusion: The minimum required front setback for a detached house in the RE-1 Zone under the standard method of development is 50 feet. Exhibit 29, pg. 10. The Conditional Use Site plan demonstrates that proposed building site is set back 50 feet from Overhill Road and the front setback. Exhibit 11, pg. 3. The Hearing Examiner finds from the record that the minimum front setback is met.

vii. The minimum side and rear setback is 25 feet to lots not included in the application.

Conclusion: The property is surrounded by county and state rights-of-way and does not abut any other lots. Therefore, this section is inapplicable.

viii. The minimum green area is 50%.

ix. The Hearing Examiner may reduce the green area requirement by up to 15% if it is necessary to accommodate a lower building height for compatibility reasons.

Conclusion: Staff and the Applicant agree that the amount of green area meets the 50% requirement. Exhibit 29, pg. 11 & T. 50. Based on this uncontroverted evidence, the Hearing Examiner finds that the application meets this requirement.

D. General Development Standards (Article 59.6)

Article 59.6 sets the general requirements for site access, parking, screening, landscaping, lighting, and signs. These requirements need be satisfied only “to the extent the Hearing Examiner finds necessary to ensure compatibility.” *Zoning Ordinance*, §59.7.3.1.E.1.b. The applicable requirements, and whether the use meets these requirements, are discussed below. The proposed use and Zone do not require the review of Division 6.1 for Site Access, Division 6.3 for Open Space and Recreation, or Division 6.6 for Outdoor Storage.

1. Parking and Loading

Parking and loading standards are governed by Division 6.2 of the Zoning Ordinance.⁵ For an Independent Living Facility for Seniors, the required number of vehicle parking spaces is based on the number of dwelling units and the maximum number of employees on a shift. Zoning Ordinance §59.6.2.4.B. calls for 1 parking space for each dwelling unit plus 0.5 spaces for each employee. The Ordinance permits a reduction for senior housing. *Zoning Ordinance*, §59.6.2.3.I.2.b. Thus, the minimum required spaces for the dwelling units proposed would be 98

⁵ Queuing requirements apply only to uses with a drive-thru, and therefore do not apply to this use. *Zoning Ordinance*, §59.6.2.7.A.

spaces. The Applicant proposes a total of 24 additional spaces than that required by Code. Both Staff and the Applicant confirm that the loading space will be provided on-site, which is shown on the Conditional Use Site Plan. Exhibits 11 and Exhibit 29, pgs. 12-13.

Conclusion: Based on the record summarized above, the Hearing Examiner finds that the parking as proposed meets the code requirements and no waivers are required. The loading requirements are satisfied per the Zoning Ordinance.

2. Site Landscaping and Screening

Conclusion: Section 59-6.5.2.B.A.2 requires the independent living facility to provide screening to properties it abuts in a residentially detached zone, however the subject property does not abut such a property in a residential detached zone. With that said, the Applicant intends to provide landscaping and screening around the proposed building, parking facilities and amenity spaces. Exhibit 29, pg. 13 and T. 31.

The Hearing Examiner accepts Staff's conclusion (Exhibit 29, pg. 13) and the undisputed statements of the Applicant's experts and finds that the Landscape and Lighting Plan (Exhibit 33a-m) meets the technical requirements of Division 6.4 and 6.5. The Hearing Examiner has already concluded that the landscaping shown is compatible with the surrounding uses; compliance with the technical requirements is necessary only to the extent needed to ensure compatibility.

3. Outdoor Lighting

Conclusion: The outdoor lighting proposed for the conditional use was discussed in Part II.C.2. of this Report and Decision. As indicated there, permissible lighting levels for a conditional use are specified in Zoning Ordinance §59.6.4.4.E., which provides,

Outdoor lighting for a conditional use must be directed, shielded, or screened to ensure that the illumination is 0.1 footcandles or less at any lot line that abuts a lot with a detached house building type, not located in a Commercial/Residential or Employment zone.

The Applicant submitted a Photometric Plan that showed illumination levels of the lighting on the subject property. Exhibit 33a-m. Mr. Slone testified that the no residential properties about the subject property and along most of the property boundaries the footcandle measurement is zero, except for the required street lighting. T. 41-42. He also opined that the lighting plan met the technical requirements of the Zoning Ordinance. T. 43.

Conclusion: Based on the undisputed evidence described above, the Hearing Examiner finds that the outdoor lighting proposed conforms to the requirements of the Zoning Ordinance.

IV. CONCLUSION AND DECISION

As set forth above, the application meets all the standards for approval in Articles 59.3, 59.4, 59.6 and 59.7 of the Zoning Ordinance.

Based on the foregoing findings and conclusions and a thorough review of the entire record, the application of Community Housing Initiative, Inc. (CU23-14) for a conditional use under Section 59.3.3.2.C.2.b. of the Zoning Ordinance to build and operate an Independent Living Facility for Seniors on property described as 16998 Overhill Road, (Tax Account No. 00117554), in Derwood, Maryland, is hereby **GRANTED**, subject to the following conditions:

1. A preliminary plan of subdivision is required.
2. The conditional use is limited to a 130 dwelling unit Independent Living Facility for Seniors.
3. The project must contain 100% affordable housing (MPDUs).
4. Upon 75% occupancy, the Applicant must make a determination based on residents' transportation need whether to add a shuttle or van service to residents to provide accessibility to shopping, medical offices, etc.
5. The facility must be operated to meet all applicable Federal, State, and County licensure, certificate, and regulatory requirements.
6. No ancillary or retail services to non-residents are permitted on-site.

7. The Applicant must abandon the existing special exception, (CBA 2778) for Horticultural Nursery/Landscape Contractor use associated with the property.
8. Occupancy of the dwelling units shall be in accordance with the provisions of the Zoning Ordinance Sections 59.3.3.2.C.2.a.iii (age of occupants) and 59.3.3.2.C.2.c.iii (income levels of the occupants), and any amendment thereto.
9. Prior to issuance of any building permit for the subject conditional use, the Applicant or any successor in interest must obtain approval of a Preliminary Plan of Subdivision and Record Plat under Chapter 50 of the Montgomery County Code. The Applicant and any successors in interest must report to OZAH any proposed changes to the conditional use plans as a result of subdivision proceedings and must file a copy of the proposed amended plans with OZAH.
10. The facility must be operated in accordance with all applicable County noise regulations.
11. The Applicant must obtain and satisfy the requirements of all licenses and permits, including but not limited to building permits and use and occupancy permits, necessary to occupy the conditional use premises and operate the conditional use as granted herein. The Applicant shall at all times ensure that the conditional use and premises comply with all applicable codes (including but not limited to building, life safety and handicapped accessibility requirements), regulations, directives and other governmental requirements, including the annual payment of conditional use administrative fees assessed by the Department of Permitting Services

Issued this 13th day of September, 2023.



Kathleen E. Byrne
Hearing Examiner

NOTICE OF RIGHT TO APPEAL

Any party of record may file a written request to appeal the Hearing Examiner's Decision by requesting oral argument before the Board of Appeals, within 10 days issuance of the Hearing Examiner's Report and Decision. Any party of record may, no later than 5 days after a request for oral argument is filed, file a written opposition to it or request to participate in oral argument. If the Board of Appeals grants a request for oral argument, the argument must be limited to matters contained in the record compiled by the Hearing Examiner. A person requesting an appeal, or

opposing it, must send a copy of that request or opposition to the Hearing Examiner, the Board of Appeals, and all parties of record before the Hearing Examiner.

Additional procedures are specified in Zoning Ordinance §59.7.3.1.f.1. Contact information for the Board of Appeals is:

Montgomery County Board of Appeals
100 Maryland Avenue, Room 217
Rockville, MD 20850
(240) 777-6600
<http://www.montgomerycountymd.gov/boa/>

**PLEASE NOTE THE FOLLOWING BOARD OF APPEALS FILING REQUIREMENTS
DURING THE COVID-19 PANDEMIC:**

The Board of Appeals website sets forth these procedures for filing documents:

Because remote operations may not always allow us to promptly date-stamp incoming U.S. Mail, until further notice, all time-sensitive filings (administrative appeals, appeals of conditional use decisions/requests for oral argument, requests for public hearings on administrative modifications, requests for reconsideration, etc.) should be sent via email to BOA@montgomerycountymd.gov, and will be considered to have been filed on the date and time shown on your email. In addition, you also need to send a hard copy of your request, with any required filing fee, via U.S. Mail, to the Board's 100 Maryland Avenue address (above). Board staff will acknowledge receipt of your request and will contact you regarding scheduling.

If you have questions about how to file a request for oral argument, please contact Staff of the Board of Appeals.

The Board of Appeals will consider your request for oral argument at a work session. Agendas for the Board's work sessions can be found on the Board's website and in the Board's office. You can also call the Board's office to see when the Board will consider your request. If your request for oral argument is granted, you will be notified by the Board of Appeals regarding the time and place for oral argument. Because decisions made by the Board are confined to the evidence of record before the Hearing Examiner, no new or additional evidence or witnesses will be considered. If your request for oral argument is denied, your case will likely be decided by the Board that same day, at the work session.

Parties requesting or opposing an appeal must not attempt to discuss this case with individual Board members because such *ex parte* communications are prohibited by law. If you have any questions regarding this procedure, please contact the Board of Appeals by calling 240-777-6600 or visiting its website: <http://www.montgomerycountymd.gov/boa/>.

NOTIFICATION OF DECISION TO BE SENT TO:

Scott C. Wallace, Esquire

Attorney for the Applicant

Carol Kosary, Opponent

Barbara Jay, Executive Director, Montgomery County Board of Appeals

Robert Kronenberg, Deputy Director, Planning Department

Mark Beall, Planning Department

Greg Nichols, Manager, Department of Permitting Services

Victor Salazar, Department of Permitting Services

Michael Coveyou, Director, Finance Department



**Department of Permitting Services
Fire Department Access and Water Supply Comments**

DATE: 27-Oct-24
TO: Jason Evans
VIKA, Inc
FROM: Marie LaBaw
RE: 16998 Overhill Road
120240060

PLAN APPROVED

1. Review based only upon information contained on the plan submitted **25-Oct-24** .Review and approval does not cover unsatisfactory installation resulting from errors, omissions, or failure to clearly indicate conditions on this plan.
2. Correction of unsatisfactory installation will be required upon inspection and service of notice of violation to a party responsible for the property.

E-FILE STAMP



VIKA MARYLAND, LLC
20251 Century Blvd., Suite 400
Germantown, MD 20874
301.916.4100 | vika.com
Our Site Set on the Future.

PREPARED FOR:
COMMUNITY HOUSING
INITIATIVE, INC.
1123 ORMOND COURT
MCLEAN, VA 22101
CONTACT: PATRICK BYRNE
(703) 556-9569
pbyrne@chidc.org

PLANNER/ENGINEER/LANDSCAPE
ARCHITECT:
VIKA MARYLAND, LLC.
20251 CENTURY BLVD., SUITE 400
GERMANTOWN, MD 20874
CONTACT: JOSH SLOAN
(301) 916-4100
sloan@vika.com

ARCHITECT:
STUDIO K
7806 JAKI TERRACE
GLEN BURNE, MD 21060
CONTACT: CHIP KEENER
(301) 938-5195
ckeener@studiokarch.net

TRAFFIC ENGINEER:
LENHART TRAFFIC
CONSULTING, INC.
645 BALTIMORE ANNAPOLIS BLVD.
SUITE 214
SEVERNA PARK, MD 21146
CONTACT: NICK DRIBAN
(410) 216-3333
mlenhart@lenharttraffic.com

ATTORNEY:
MILES & STOCKBRIDGE
11 NORTH WASHINGTON STREET
SUITE 700
ROCKVILLE, MD 20850
CONTACT: SCOTT WALLACE
(301) 762-1600
swallace@MilesStockbridge.com

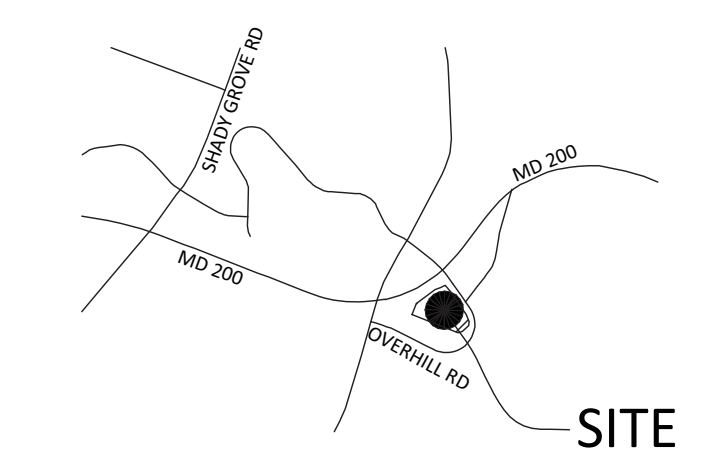

VICINITY MAP

Legend

- MAIN ENTRANCE
- WATER LINE AND FITTING
- FIRE DEPARTMENT CONNECTION
- FIRE HYDRANT
- BUILDING ENTRY
- FIRE TRUCK MOVEMENT (AT 729 TRUCK)
- FIRE ACCESS PATH
- FIRE ACCESS FOOT PATH
- LOWEST ELEVATION ALONG FIRE LANE

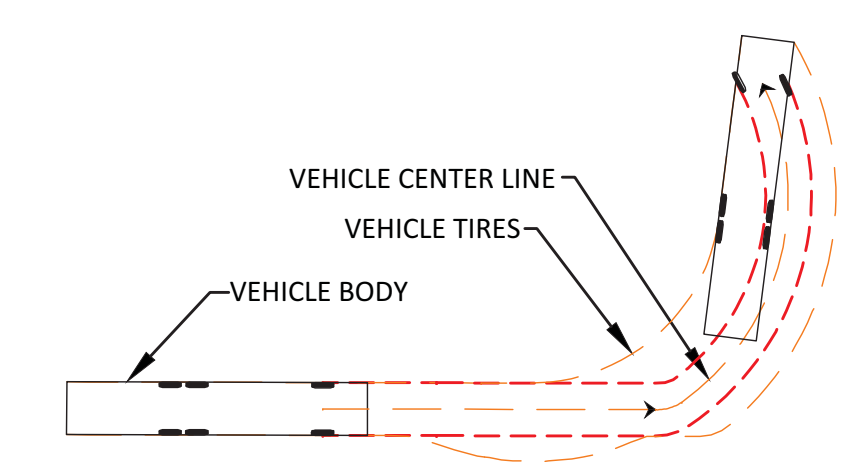

REVISIONS	DATE

16998
OVERHILL
ROAD
4TH ELECTION DISTRICT
MONTGOMERY COUNTY,
MARYLAND
WSSC GRID: 223NW07
TAX MAP: GT41

FIRE
ACCESS
PLAN

120230060



I HEREBY CERTIFY THAT THESE DOCUMENTS WERE PREPARED OR APPROVED BY ME, AND THAT I AM A DULY LICENSED PROFESSIONAL ENGINEER UNDER THE LAWS OF THE STATE OF MARYLAND.
LAST NAME: JENKINS, FIRST NAME: EVANS, E
LICENSE NUMBER: 3985
EXPIRATION DATE: 08/15/2025

THE INFORMATION, DESIGN AND CONTENT OF THESE DRAWINGS OR DOCUMENTS ARE PROPRIETARY TO VIKA MARYLAND, LLC AND CONSTITUTE ITS PROPRIETARY INTELLECTUAL PROPERTY. THESE DRAWINGS AND/OR COPIES, DIGITALLY CONVERTED, MODIFIED OR USED FOR ANY PURPOSE, IN ANY FORMAT, WITHOUT WRITTEN AUTHORIZATION FROM VIKA MARYLAND, LLC, VIOLATION MAY RESULT IN PROSECUTION. ONLY APPROVED, SIGNED AND SEALED PLANS OR DRAWINGS MAY BE UTILIZED FOR CONSTRUCTION PURPOSES.

© 2025 VIKA MARYLAND, LLC
DRAWN BY: KP
DESIGNED BY: JS/KP
DATE ISSUED: 9/16/2022

VIKA PROJECT 50571
DRAWING NO.

SHEET NO. FIRE-1

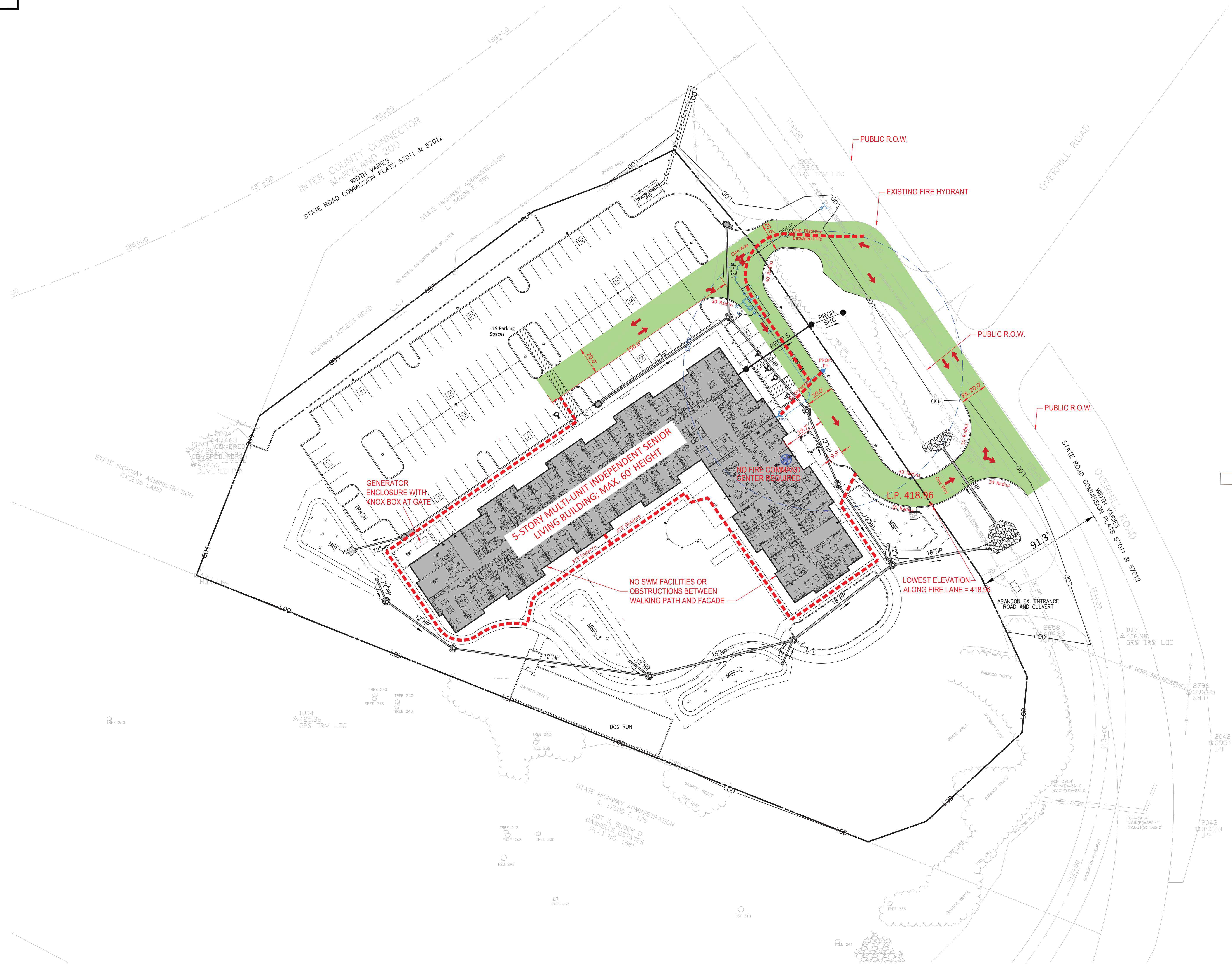

FIRE CODE ENFORCEMENT
Fire Department Access Review
Review based upon information contained on this plan. Does not cover unsatisfactory layout resulting from omissions, errors or failure to clearly indicate conditions on this plan. Correction of such unsatisfactory layout to afford required access will be required if found upon inspection after installation.
BY: S.M.C. PW: 43 DATE: 10/27/2024

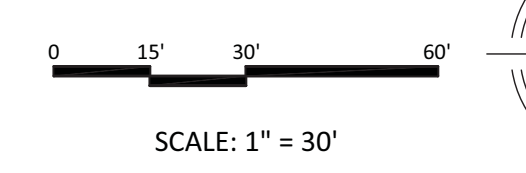
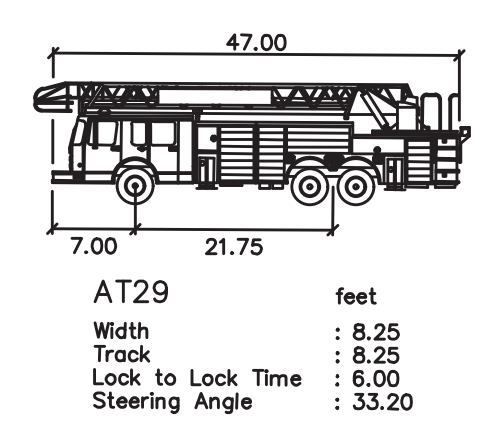

"FOR LOCATION OF UTILITIES CALL 8-1-1 or 1-800-257-7777 OR LOG ON TO www.call811.com or http://www.missutility.net 48 HOURS IN ADVANCE OF ANY WORK IN THIS VICINITY"
The excavator must notify all public utility companies with underground facilities in the area of proposed excavation and have those facilities located by the utility companies prior to commencing excavation. The excavator is responsible for compliance with requirements of Chapter 36A of the Montgomery County Code.

November 26, 2024

Mr. Justine González-Vélez, Planner II
Upcounty Planning Division
The Maryland-National Capital
Park & Planning Commission (M-NCPPC)
2425 Reedie Drive, Wheaton, MD 20902

Dear Mr. González-Vélez:

Thank you for the opportunity to review Preliminary Plan 120240060 for the **16998 Overhill Road development** located on Overhill Rd. The State Highway Administration (SHA) has reviewed the application and is pleased to respond.

Overhill Road is currently under SHA ownership but is not currently maintained by SHA and is in the process of being transferred to Montgomery County. Based on preliminary review of the plans, SHA recommends approval of the Preliminary Plan and will not require an Access permit for improvements on Overhill Rd. Further coordination regarding this access should be done with Montgomery County directly.

If you have any questions or require additional information, please contact Mr. Kwesi Woodroffe at 301-513-7347, by using our toll free number (in Maryland only) at 1-800-749-0737 (x7347), or via email at kwoodroffe@mdot.maryland.gov.

Sincerely,



11/26/24

Derek Gunn, P.E.
District Engineer, District 3, SHA

DG/kw

Cc: Katherine Mencarini, Montgomery County Planning Department
Deepak Somarajan, MCDOT



November 12, 2024

Mr. Mark Beall, Planner IV
Upcounty Planning Division
The Maryland-National Capital
Park & Planning Commission (M-NCPPC)
2425 Reddie Drive,
Wheaton, MD 20902

RE: Preliminary Plan Letter
Preliminary Plan No. 120240060
16998 Overhill Road

Dear Mr. Beall:

We have completed our review of the revised Preliminary Plan uploaded to eplans on November 4, 2024. A previous Preliminary Plan was reviewed by the Development Review Committee at its February 27, 2024, meeting. This item is tentatively scheduled for the January 9, 2025, Planning Board meeting. We recommend approval for the plan based on the following comments:

Preliminary Pan Comments

1. Overhill Road: This roadway along the site frontage is currently state-maintained and is being transferred to the County.
2. If at the time of right-of-permit, the transfer of the Overhill Road maintenance is **not complete**, we have the following recommendations for the Maryland State Highway Administration (MDSHA)'s consideration:
 - a. We agree to waive the sidewalk along the frontage, considering the existing steep slopes and impacts to the stream valley buffer as per the plans provided in the eplans.
 - b. **Sight Distance**: We reviewed the sight distance, and we approve with the condition that trees, shrubs, and any obstructions in the line of sight must be cleared prior to the plat's recording. We defer to MDSHA for approval.
 - c. **Storm Drain Analysis**: The storm drain report dated June 2024 and uploaded to eplans on October 25, 2024, is acceptable. Therefore, the applicant is not responsible for any improvements to the existing downstream public storm drain system for this plan. We defer to MDSHA for approval for impacts to any MDSHA-maintained storm drain system.
 - d. The proposed driveways shall meet MC 302.01.

- e. The temporary turnaround shall meet the MC-223.02.
3. If the transfer of the Overhill Road maintenance is **complete** at the time of the right-of-permit, posting the ROW permit bond will be a prerequisite to Montgomery County Department of Permitting Services (MCDPS) approval of the record plat.

Standard Plan Review Comments

1. All Planning Board Opinions relating to this plan or any subsequent revision, project plans, or site plans should be submitted to the MCDPS in the package for record plans, storm drains, grading or paving plans, or applications for access permits. Include this letter and all other correspondence from this department.
2. Design all access points and alleys to be at-grade with the sidewalk, dropping down to street level between the sidewalk and roadway. Driveway aprons should be provided for all alleys.
3. Permanent structures such as steps, stoops, walls, etc., are not allowed in the public right-of-way (ROW).
4. We recommend a 10-Public Utility Easement (PUE) along all street frontages.
5. Relocation of utilities along existing roads to accommodate the required roadway improvements shall be the responsibility of the applicant.

Thank you for the opportunity to review this preliminary plan. If you have any questions or comments regarding this letter, please contact Mr. Deepak Somarajan, our Development Review Engineer for this project at deepak.somarajan@montgomerycountymd.gov or at (240) 777-7170.

Sincerely,

Deepak Somarajan, Engineer III
Development Review Team
Office to Transportation Policy

SharePoint\teams\DOT\Director's Office\Development Review\Deepak\Preliminary Plan\120240060-16998 Overhill Road\Letter\
120240060-16998 Overhill Road-MCDOT Prelim ltr

cc: Sharepoint Correspondence Folder FY'25

cc-e: Sachin Kalbag VIKA

Kwesi Woodroffe	MDSHA District 3
Jonathan Casey	MNCPPC
Justine Gonzalez-Velez	MNCPPC
Tiara McCray	MCDOT DTE
Eric Willis	MCDOT DTE
Atiq Panjshiri	MCDPS RWPR
Sam Farhadi	MCDPS RWPR
Mark Terry	MCDOT DTEO
Mark Etheridge	MCDPS WRS
Sherryl Mitchell	MCDPS WRS
Rebecca Torma	MCDOT OTP



DEPARTMENT OF PERMITTING SERVICES

Marc Elrich
County Executive

Rabbiah Sabbakhan
Director

October 24, 2024

Mr. Jason Evans
VIKA LLC
20251 Century Boulevard
STE 400
Germantown, MD 20874

Re: **COMBINED STORMWATER MANAGEMENT
CONCEPT/SITE DEVELOPMENT
STORMWATER MANAGEMENT PLAN** for
16998 Overhill Road
Preliminary Plan #: 120230060
SM File #: 288872
Tract Size/Zone: 3.78 ac.
Total Concept Area: 4.39 ac
Lots/Block: P6/ D
Watershed: Upper Rock Creek
Redevelopment (Yes/No): No

Dear Mr. Evans:

Based on a review by the Department of Permitting Services Review Staff, the stormwater management concept for the above-mentioned site is **acceptable**. The plan proposes to meet required stormwater management goals via ESD to the MEP using 5 Micro Bioretention facilities.

The following items will need to be addressed during the detailed sediment control/stormwater management plan stage:

1. A detailed review of the stormwater management computations will occur at the time of detailed plan review.
2. An engineered sediment control plan must be submitted for this project.
3. All filtration media for manufactured best management practices, whether for new development or redevelopment, must consist of MDE approved material.
4. An acceptable Geotechnical analysis and recommendation for the final design and construction of the concrete Micro Bioretention Planter boxes near rubble fill areas will be a requirement prior to plan approval.
5. If the Maryland State Highway Administration (MSHA) requires stormwater management for work associated with an access permit, the stormwater management practice(s) must be within the MSHA right-of-way and must be inspected during construction maintained after construction by MSHA. The MSHA approved stormwater management design and associated disturbed areas for



2425 Reedie Drive, 7th Floor, Wheaton, Maryland 20902 | 240-777-0311
www.montgomerycountymd.gov/permittingervices

Mr. Jason Evans
October 24, 2024
Page 2 of 2

the access permit must be shown as a part of the DPS sediment control plan set and will be covered by the DPS issued sediment control permit.

6. Any proposed grading within the Stream Valley Buffer will require prior approval from MNCPPC.

This list may not be all-inclusive and may change based on available information at the time.

Payment of a stormwater management contribution in accordance with Section 2 of the Stormwater Management Regulation 4-90 **is not required**.

This letter must appear on the sediment control/stormwater management plan at its initial submittal. The concept approval is based on all stormwater management structures being located outside of the Public Utility Easement, the Public Improvement Easement, and the Public Right of Way unless specifically approved on the concept plan. Any divergence from the information provided to this office; or additional information received during the development process; or a change in an applicable Executive Regulation may constitute grounds to rescind or amend any approval actions taken, and to reevaluate the site for additional or amended stormwater management requirements. If there are subsequent additions or modifications to the development, a separate concept request shall be required.

If you have any questions regarding these actions, please feel free to contact Joel Karpas at 240-777-6206.

Sincerely,



Mark Etheridge, Manager
Water Resources Section
Division of Land Development Services

cc: Neil Braunstein
SM File # 288872

ESD: Required/Provided 11,360 cf / 11,468 cf
PE: Target/Achieved: 1.80"/1.82"
STRUCTURAL: 0 cf
WAIVED: 0 cf.

**PRELIMINARY PLAN 120240060 &
FOREST CONSERVATION PLAN F20230060**

16998 OVERHILL ROAD

PRE-SUBMISSION COMMUNITY MEETING

MEETING DATE: DECEMBER 5, 2023

Applicant Team	
Joseph Byrne	CHI (Applicant)
Josh Sloan	VIKA
Sachine Kalbag	VIKA

MINUTES

The meeting was opened at 7:00 and started at 7:03 after waiting to see if additional participants would join. With only one neighbor attending, the discussion was more open than the typical for these meetings. A slide deck of 11 slides was posted more than 5 days before the meeting and was available for download and review. These slides were used as the framework for discussion.

From 7:03 to 7:07 Josh Sloan reviewed the agenda and format of the meeting and introduced the team.

Given that there was only one participant, the discussion focused on two elements and a general question about timing:

1. The noise study and noise from the abutting Intercounty Connector (MD-200)
 - a. Comment: Is the noise calculation based on an average over time?
Response: The methodology was calculated based on regulations; the proposed development was not modeled and Mr. Sloan described some of the elements going into sound mitigation. Standards for indoor and outdoor sound levels were provided.
 - b. Comment: The sound walls and berms provided along the ICC are not provided along the stormwater pond and that gap allows a lot of noise into the neighborhood. Is that gap part of the property?
Response: The area along the SWM gap is owned by the State and is not being modified by the Applicant. The building shape will address

- sound from that gap on the subject site.
- c. Comment: The lack of mitigation along the gap is a concern for the neighborhood and will be brought up if there is some kind of hearing.
Response: The Applicant cannot provide mitigation on State property but the Planning Board can make a request on the neighborhood's behalf to the State. The process for review, notification, and public participation was then outlined.
2. Traffic Study methodology and impacts
 - a. Comment: 130 apartments for seniors with parking is proposed; how are traffic counts defined?
Response: Regulations require use of ITE calculations, as modified by County adjustment rates, per unit and housing type
 - b. Comment: Any consideration made for single access to Redland Road?
Response: No concern was raised regarding this intersection based on the Traffic Statement.
 - c. Comment: School-age children walking to and from the school bus stop have no sidewalks and there is a concern about number of units and age of drivers.
Response: Understood and follow up question: where is the children's bus stop? (Which was provided – Redland Road & Overhill Road).
 3. What is general timeline?
 - a. Response: The anticipated steps in the process through review, permitting, and construction start was outlined; potential construction start of mid- to late-2024 was provided.

At 7:29, Mr. Sloan summarized next steps and contact information was provided for any follow up questions or comments. Mr. Maciorowski's status as a part of record on the notice list was confirmed.

The meeting ended at 7:31.